

Fisher™ 9500 Butterfly Control Valve

Contents

Introduction	1
Scope of Manual	1
Description	1
Installation	3
Adjustments	6
Hub Seals	6
Linkage	8
Three-Way Valve Tandem Linkage	8
Maintenance	9
Disassembly	9
Reassembly	11
Actuator Mounting	13
Changing Disc Rotation and Action	14
Parts Ordering	16
Parts List	16

Figure 1. Fisher 9500 Valve with 1052 Actuator and DVC6200 Digital Valve Controller



W9224-2

Introduction

Scope of Manual

This manual provides installation, adjustment, and maintenance information for Fisher 9500 butterfly valves. These valves use splined shafts with actuator-mounted brackets and linear-motion actuators (see figure 1). Refer to separate manuals for instructions covering the power actuator or the manual handwheel actuator, positioner, and other accessories.

Do not install, operate, or maintain 9500 valves without being fully trained and qualified in valve, actuator, and accessory installation, operation, and maintenance. To avoid personal injury or property damage, it is important to carefully read, understand, and follow all the contents of this manual, including all safety cautions and warnings. If you have any questions about these instructions, contact your [Emerson sales office](#) or Local Business Partner before proceeding.

Description

The 9500 valve is a fully lined butterfly valve for use with corrosive process fluids or wherever stringent shutoff is required. The nitrile or PTFE liner completely isolates the valve body and shaft from the process fluid. The valve is available with conventional or FISHTAIL™ disc designs.

Table 1. Specifications

<p>Valve Sizes NPS ■ 2, ■ 3, ■ 4, ■ 6, ■ 8, ■ 10, or ■ 12</p> <p>Valve Body Style Flangeless (wafer-type) valve body to be installed between pipeline flanges</p> <p>End Connection Styles Flangeless (wafer-style) valve body mates with CL125 flat-face flanges per ASME B16.1, with CL150 and 300 raised-face flanges per ASME B16.34, or EN flanges</p> <p>Maximum Allowable Inlet Pressure⁽¹⁾ Consistent with applicable pressure/temperature ratings for ■ CL125B per ASME B16.1, or ■ CL150 and 300 per ASME B16.34 unless limited by maximum allowable pressure drop specification or by material temperature capabilities in table 2</p> <p>Vacuum Service The valve is suitable for vacuum service to approximately 10⁻⁷ mm Hg absolute (3.4 x 10⁻¹² mbar, absolute)</p> <p>Maximum Shutoff Pressure Drop⁽¹⁾ Standard Operation Cast Iron Valve: 12.1 bar (175 psi) Steel or Stainless Steel Valve: 15.2 bar (220 psi)</p> <p>Material Temperature Capabilities⁽¹⁾ See table 2</p> <p>Flow Characteristic Conventional Disc: Approximately equal percentage through 60 degrees of disc rotation</p>	<p>FISHTAIL Disc: Approximately equal percentage through 90 degrees of disc rotation</p> <p>Flow Direction Conventional Disc: Bidirectional FISHTAIL Disc: Forward flow - The tail of the disc opens into the downstream end of the valve (see figure 2).</p> <p>Disc Rotation Conventional Disc On/Off Service: ■ 0 to 60 or ■ 0 to 90 degrees Throttling Service: 0 to 60 degrees FISHTAIL Disc: 0 to 60 or 0 to 90 degrees for on/off or throttling</p> <p>Shutoff Classification per ANSI/FCI 70-2 and IEC 60534-4 Nitrile Liner or PTFE Liner: Class VI</p> <p>Mating Flange Capabilities All sizes compatible with welding-neck flanges; also see Installation section for slip-on flanges</p> <p>Code Classifications Dimensions meet MSS SP-67 specifications for face-to-face dimensions for flangeless valves</p> <p>Approximate Weights (Valve Body Assemblies Only) NPS 2: 9 kg (20 lb) NPS 3: 11 kg (25 lb) NPS 4: 14 kg (30 lb) NPS 6: 20 kg (45 lb) NPS 8: 27 kg (60 lb) NPS 10: 32 kg (70 lb) NPS 12: 54 kg (120 lb)</p>
--	--

1. The pressure/temperature limits in this manual and any applicable standard or code limitation should not be exceeded.

Table 2. Operative Temperature

Disc Type	Liner Material	Operative Temperature
Conventional or FISHTAIL	Nitrile	-7 to 93°C (20 to 200°F)
	PTFE	-18 to 121°C (0 to 250°F)

Installation

⚠ WARNING

Always wear protective gloves, clothing, and eyewear when performing any installation operations to avoid personal injury.

Personal injury or equipment damage caused by sudden release of pressure may result if the valve assembly is installed where service conditions could exceed the limits given in table 1 or on the appropriate nameplates. To avoid such injury or damage, provide a relief valve for over-pressure protection as required by government or accepted industry codes and good engineering practices.

Check with your process or safety engineer for any additional measures that must be taken to protect against process media.

If installing into an existing application, also refer to the WARNING at the beginning of the Maintenance section in this instruction manual.

These valves may be installed in many positions by referring to the Actuator Mounting procedures and figure 6 in this manual. For conventional discs, flow may be in either direction. For FISHTAIL discs, the leading edge of the disc must be located in the upstream end of the valve (see figure 2).

CAUTION

As noted in the following paragraphs, improper use of additional gasketing materials will damage the valve liner.

The valve body liner extends past or overlaps the valve face producing the partial O-ring shown in figure 3. It also acts as the flange gasket. Improper use of additional gasketing materials will damage the valve liner.

Care must be taken during installation to ensure that the pipe flanges are properly supported. Pipe flange support is required to avoid liner flange joint leakage or problems during valve operation. Slip-on pipe flanges may be used with NPS 2, 3, or 4 valves. An NPS 6 valve or larger will require flange adapters for complete liner support.

Mating flanges or pipe flanges with inside diameters smaller than the minimum shown (see table 3) may interfere with the opening of the disc. Flanges or pipes with an inside diameter larger than the maximum shown (see table 3) may not be in full contact with the liner. Install flange adapters in each case, either to provide disc clearance or to fully contact the liner.

Flexible, plastic flanges, fiberglass, slip-on, or weld-neck with other than standard inside diameters may not provide adequate support for the liner. Also, flexible mating flanges can be warped with excessive line bolt load. They may fail to support the liner at the inside diameter of the valve body. Use flange adapters, available from Emerson Automation Solutions, during installation to avoid these problems. Whenever a flange adapter is used, a standard flange gasket must be installed between the line flange and flange adapter. Do not use a flange gasket between the valve and flange adapter. The partial O-ring on the liner acts as the flange gasket and any additional gasket here will damage the liner.

The 9500 valve may be used as part of a three-way valve assembly. The actuator-valve linkage is adjusted at the factory; you won't need to adjust the linkage before placing the valve in service. If the valve and actuator are being re-installed, after removal, or if you suspect that the linkage is out of adjustment, refer to the Linkage portion of the Adjustments section before installing the valve in the pipeline. If the valve has been purchased separately, or if the actuator has been removed, complete the procedures in the Actuator Mounting section of this manual before proceeding.

Table 3. Maximum and Minimum Allowable Mating Flange Diameters

VALVE SIZE, NPS	MAXIMUM AND MINIMUM DIAMETER OF MATING PIPING OR FLANGES			
	Minimum		Maximum	
	mm	Inches	mm	Inches
2	30	1.20	64	2.50
3	64	2.50	92	3.62
4	89	3.50	117	4.62
6	145	5.70	171	6.75
8	196	7.70	222	8.75
10	246	9.70	273	10.75
12	297	11.70	330	13.00

Figure 2. Valve Shaft Marking

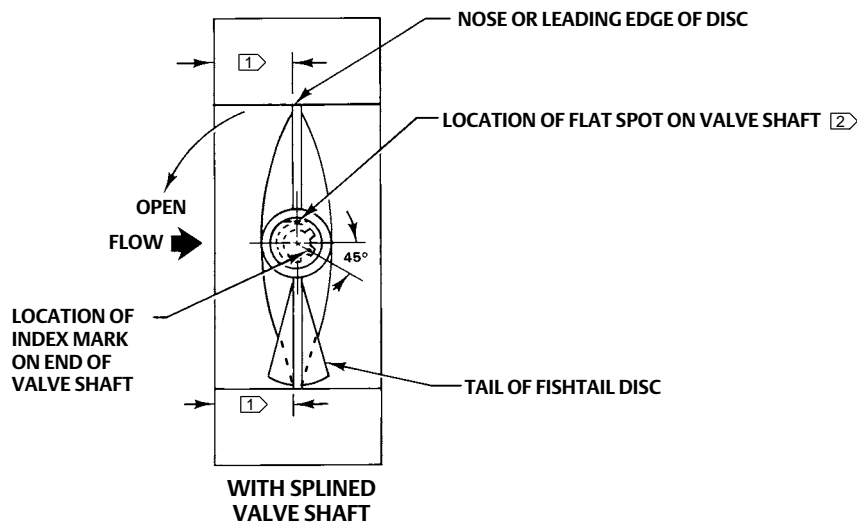

① EQUAL MEASUREMENTS BETWEEN VALVE FACE AND DISC EDGE AT TOP AND BOTTOM ENSURE FULLY CLOSED DISC.

② FOR FISHTAIL DISC, PARTIAL KEYWAY OR FLAT SPOT IS ON SAME SIDE AS NOSE OF DISC.

A2755-1

⚠ WARNING

Avoid personal injury from sudden release of process pressure. Before performing any maintenance operations:

- Do not remove the actuator from the valve while the valve is still pressurized.
- Always wear protective gloves, clothing, and eyewear when performing any maintenance operations to avoid personal injury.
- Disconnect any operating lines providing air pressure, electric power, or a control signal to the actuator. Be sure the actuator cannot suddenly open or close the valve.
- Use bypass valves or completely shut off the process to isolate the valve from process pressure. Relieve process pressure on both sides of the valve. Drain the process media from both sides of the valve.
- Vent the power actuator loading pressure and relieve any actuator spring precompression.
- Use lock-out procedures to be sure that the above measures stay in effect while you work on the equipment.
- The valve packing box may contain process fluids that are pressurized, *even when the valve has been removed from the pipeline*. Process fluids may spray out under pressure when removing the packing hardware or packing rings, or when loosening the packing box pipe plug.

Figure 3. Partial O-Ring Location

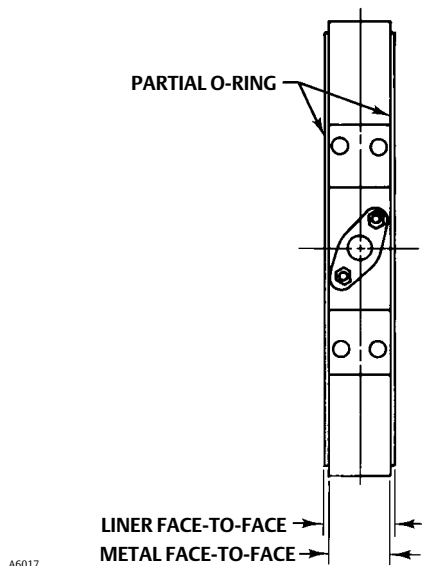

1. Isolate the control valve from the line pressure, release pressure from both sides of the valve body, and drain the process media from both sides of the valve. If continuous operation is required during inspection or maintenance, install a three-valve bypass around the control valve assembly.
2. Be certain the pipeline flanges are in line with each other and supported.

CAUTION

To avoid damaging valve seating surfaces, make sure the adjacent piping is free of pipe scale, welding slag, and any other damaging material.

3. Inspect the valve body to be sure it is free of foreign material. Make sure the adjacent piping is free of pipe scale, welding slag, and any other material that could damage valve seating surfaces.
4. Measure to be sure the distance between the pipeline flanges is approximately 1/4 inch greater than the valve face-to-face dimension. This will ensure easy installation without distorting the liner (figure 3).
5. For conventional discs, flow may be in either direction; for FISHTAIL discs, flow must be such that the tail of the disc (as shown in figure 2) will rotate into the downstream side of the valve.

CAUTION

To avoid damaging valve parts, observe the following precautions before inserting the valve in the line.

- a. The inside diameter of the mating piping or flanges must be large enough to allow the valve disc to rotate freely into the upstream and downstream piping, or the disc could be damaged. Do not use piping or flanges having an inside diameter smaller than the minimum shown in table 3.
- b. The inside of the mating flange must also be small enough to be in full contact with the partial O-rings on the liner faces. Leakage through the flange connections and damage to the liner could result if the partial O-ring

faces are not properly supported. Do not use flanges having an inside diameter larger than the maximum shown in table 3.

NPS 6 to 10 valves must not be used with slip-on flanges unless flange adaptors are used to support the liner. When using slip-on flanges with other sizes, be certain the valve is carefully centered to ensure that the partial O-ring faces are in full contact with the adjacent flanges.

- c. When a flange adapter is necessary, a flange gasket must be installed between the line flange and the flange adapter. Do not use a flange gasket between the valve and the flange adapter. Additional gasketing material at this location could damage the liner.
 - d. The valve disc must be in the closed position when the valve is being inserted into the pipeline. If the valve disc is not closed, it could be damaged against the mating piping or flanges.
6. Insert the valve into the pipeline. Insert four flange studs or bolts through the flanges to support the valve.
 7. Center the valve carefully on the flanges by measuring equal distances at the top and bottom and equal distances at the sides.
 8. Insert the remaining flange studs or bolts. Tighten the studs or bolts evenly. Normal flange bolt torques may be used because liner compression is limited by metal-to-metal contact between flanges and the valve body.
 9. Rotate the valve disc manually to be certain the disc clears the adjacent piping or flanges as it opens. If necessary, disconnect the power actuator-valve linkage, but do not disturb the adjustment of the turnbuckle or adjustable linkage. If the disc hits the flange, loosen flange bolting temporarily while re-centering the valve. If the problem cannot be corrected in this manner, it will be necessary to use line flanges with larger inside diameters adjacent to the valve.
 10. For hazardous atmosphere or oxygen service valves, read the following Warning, and provide the following bonding strap assembly if the valve is used in an explosive atmosphere.

⚠ WARNING

The valve drive shaft is not necessarily grounded to the pipeline when installed. Personal injury or property damage could result, if the process fluid or the atmosphere around the valve is flammable, from an explosion caused by a discharge of static electricity from the valve components. If the valve is installed in a hazardous area, electrically bond the drive shaft to the valve.

11. Attach the bonding strap assembly (key 131, figure 4) to the shaft with the clamp (key 130, figure 4).
12. Connect the other end of the bonding strap assembly to the valve flange cap screws.

Adjustments

Hub Seals

Key number locations are shown in figure 7.

Thrust sleeve assemblies (key 6) seal the disc hubs. In time, especially with frequent valve disc rotation, these seals may require adjustment.

Adjust the seals if there is leakage through the valve body around the valve shaft. A small amount of leakage downstream (between the bushings and disc hubs) may also indicate a need for hub seal adjustment.

Figure 4. Grounding Assembly

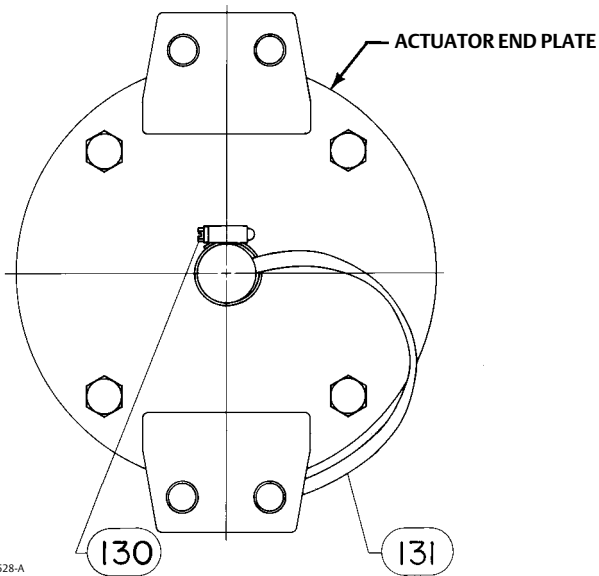

To adjust the hub seals:

1. Tighten both thrust-plate cap screws (key 10) 1/4 turn on one side (the side where shaft leakage is occurring).

CAUTION

To avoid excessive side thrust on the disc and possible liner damage, tighten cap screws on both sides of the valve alternately and in 1/4-turn increments. Do not over-tighten by continuous turning or by tightening one side only. Over-tightening the cap screws will cause the liner to fail.

2. Tighten both thrust-plate cap screws 1/4 turn on the other side of the valve.
3. Repeat steps 1 and 2 until leakage stops.

Note

If this adjustment is being performed to stop minor leakage past the disc, check the leakage after turning the cap screws enough to move the thrust plates 0.8 mm (1/32 inch) closer to the valve body. If leakage has not stopped or diminished, the leakage is probably due to incorrect linkage adjustment or damaged valve parts. Refer to the Linkage section to check linkage adjustment; refer to the Maintenance section to inspect and replace parts.

4. If leakage around the shaft cannot be stopped by adjusting hub seals, refer to the Maintenance section to inspect and replace damaged parts.

Figure 5. Tandem Linkage Adjustment for Three-Way Valve Assemblies

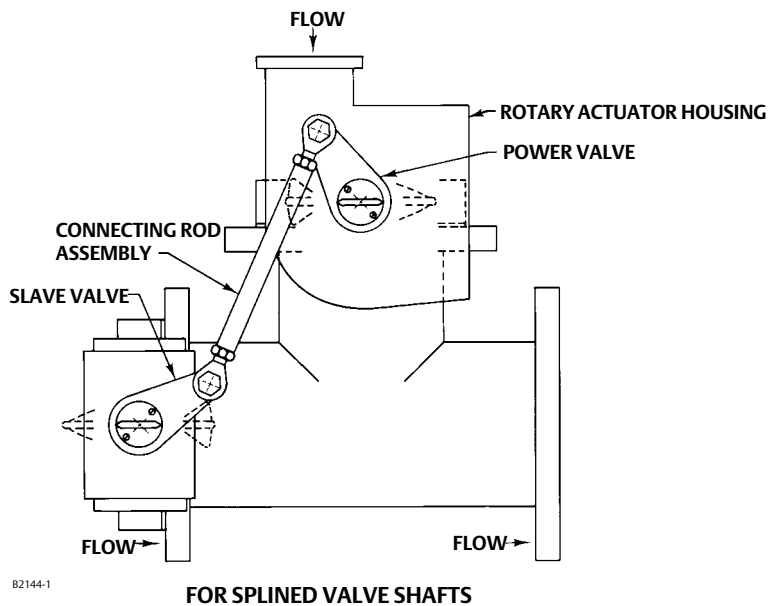

Linkage

If the linkage between the power actuator and valve is improperly adjusted, the actuator may reach the end of travel before (or after) the disc reaches the fully closed position. This could result in leakage past the disc. The linkage adjustment is set at the factory, and it should not be necessary to adjust linkage unless the actuator and valve have been separated and the adjustment altered.

To check the linkage adjustment on FISHTAIL discs, the flat is on the same side of the shaft as the nose or leading edge of the valve disc (as shown in figure 2). When the valve disc is at the fully closed position, the flat will be either top-dead-center or bottom-dead-center in relation to the valve body. The top-dead-center position is shown in figure 2. A more accurate check of the fully closed disc position is obtained by removing the valve from the pipeline.

⚠ WARNING

To avoid personal injury and damage to the process system caused by the sudden release of pressure, isolate the control valve from all pressure and relieve pressure from the valve body before removing the valve from the line. Be sure the disc is closed so that it will not hit the mating flanges when being removed from the line.

With the valve removed from the line, position the actuator to the valve-closed end of the travel. Measure the distance between the valve face and the top and bottom edges of the disc as shown in figure 2. The disc is at the fully closed position if the two measurements are equal.

To adjust linkage, refer to the actuator instruction manual.

Three-Way Valve Tandem Linkage

If the valve is used as part of a three-way valve assembly, adjustment of the tandem linkage (see figure 5) may be necessary to ensure proper rotation of the slave valve disc.

If the adjustment is being performed with the three-way valve assembly out of the line, temporarily bolt the valve bodies to the tee to compress the liner faces until there is metal-to-metal contact between the valve bodies and the tee.

Check the rotation of the power valve disc per instructions in the Linkage section. If necessary, adjust the linkage between the actuator and the power valve.

To check the fully closed position of the slave valve disc, use the partial keyway on the slave valve shaft or measure equal distances between the slave valve face and the top and bottom of the slave valve disc as described in the Linkage section. Tighten the locknuts on the tandem linkage when adjustment is complete.

Maintenance

Use table 4 to locate and correct possible leakage or mechanical linkage problems with the valve.

⚠ WARNING

Avoid personal injury from sudden release of process pressure. Before performing any maintenance operations:

- Do not remove the actuator from the valve while the valve is still pressurized.
- Always wear protective gloves, clothing, and eyewear when performing any maintenance operations to avoid personal injury.
- Disconnect any operating lines providing air pressure, electric power, or a control signal to the actuator. Be sure the actuator cannot suddenly open or close the valve.
- Use bypass valves or completely shut off the process to isolate the valve from process pressure. Relieve process pressure on both sides of the valve. Drain the process media from both sides of the valve.
- Vent the power actuator loading pressure and relieve any actuator spring precompression.
- Use lock-out procedures to be sure that the above measures stay in effect while you work on the equipment.
- The valve packing box may contain process fluids that are pressurized, *even when the valve has been removed from the pipeline*. Process fluids may spray out under pressure when removing the packing hardware or packing rings, or when loosening the packing box pipe plug.
- Check with your process or safety engineer for any additional measures that must be taken to protect against process media.

1. Isolate the control valve from the line pressure, release pressure from both sides of the valve body, and drain the process media from both sides of the valve.

Disassembly

Key numbers locations are shown in figure 7.

1. Loosen all flange studs or bolts. Remove all but the bottom flange studs or bolts.

CAUTION

To avoid damage to the valve disc caused by the disc hitting the mating flange, be certain the disc is closed before removing the valve from the pipeline.

Table 4. Troubleshooting Guide

Fault	Possible Cause	Correction
1. Leakage out sides of valve (at thrust plates) between thrust bushings and shaft.	a. Hub seals require adjustment. b. Taper pins are not sealed.	a. Adjust using Hub Seals portion of Adjustments procedures. b. Remove valve from line and re-seat taper pins or install new taper pins using Maintenance procedures.
2. Leakage out sides of valve (at thrust plates) between valve body and thrust bushings, leakage at flanges, faces, or both	a. Flange gaskets used. b. Partial O-ring bead on liner faces damaged.	a. Check to see if flange gaskets are being used; if so, remove gaskets. b. Replace liner using Maintenance procedures.
3. Leakage through disc/liner seal	a. Hub seals require adjustment. b. Linkage requires adjustment. c. Actuator has insufficient torque output to close disc against pressure drop. (Actuators are selected to have sufficient torque output to shut off the flow against a specific pressure drop, not necessarily against the maximum allowable pressure drop. Be sure that the pressure drop for which the actuator is selected is not being exceeded.) d. Liner has been damaged by flowing medium or other valve parts damaged by being subjected to service conditions beyond those for which valve is designed.	a. Adjust seals using Hub Seals portion of Adjustments procedures. b. Refer to Linkage portion of Adjustments procedures. c. If possible, check shutoff at lower pressure drops. If shutoff is obtained at low pressure drops, but actuator stalls and does not produce full disc rotation at service pressure drop, actuator output torque is too low. For piston actuators, it may be possible to increase output torque by increasing supply pressure. Do not exceed maximum allowable supply pressure of actuator. d. Inspect and replace parts using Maintenance procedures.
4. Valve shaft will not rotate	a. If actuator does not stall, but shaft does not rotate, the spline teeth on the valve shaft are sheared. b. If actuator stalls, shaft is binding in bushings due to linkage misalignment caused by excessive wear of linkage parts. c. If actuator stalls and linkage is not misaligned, actuator may have insufficient output torque to rotate disc against flow.	a. Refer to the actuator instruction manual to remove actuator cover plate. Replace valve shaft using Maintenance procedures if spline teeth are sheared. b. Replace linkage parts. c. Check actuator operation with no pressure applied to the valve. If valve now functions properly, actuator is too small.
5. Valve shaft rotates, but valve does not control process fluid	Taper pins (or drive shaft spline for coated-disc constructions) have been sheared due to obstruction to disc rotation or other internal parts damaged by being subjected to service conditions beyond those for which the valve was designed.	Inspect and replace parts using the Maintenance procedures.

2. If necessary, pry flanges apart so that liner faces will not be damaged when the valve is being removed. Inspect the disc (key 3) and liner (key 2) for wear or damage.
3. Remove the actuator from the valve. Follow instructions in the appropriate actuator instruction manual.
4. From both sides of valve, unscrew thrust-plate cap screws (key 10) and remove thrust plates (key 9).
5. If taper pin (key 15) ends are peened, grind off the peened portions. Driving from the smaller end of the pins, drive the pins out of the disc (key 3) and shaft (key 4).

⚠ WARNING

Once the shaft has been removed, the disc may fall from the valve body, causing personal injury or disc damage. Support the disc before removing the shaft.

6. Pull the shaft out of the valve body. If the shaft cannot be pulled from the valve body, drive the shaft out but use care to avoid upsetting the end of the shaft.
7. Remove the disc from the valve body.

8. Remove the liner (key 2) from the valve body.

Some 9500 valves have the liner bonded to the valve body. If the valve has a bonded liner, burn or chip out the liner.

To strip the liner out with solvent, use Dynasolve 185, or equivalent solvent. (Dynasolve is a product of DYNALLOY™ Inc.). Cover the valve with solvent bath or enclose the solvent bath around the liner. Remove all adhesive after the liner has been removed.

Table 5. Taper Pin Details for 9500 Series Valves

VALVE SIZE, NPS	SHAFT DIAMETER mm (Inches)	AMERICAN STANDARD TAPER PIN SIZE	DRILL SIZE
2	12.7 (1/2)	2	#20 (0.161 Inches)
3, 4	15.9 (5/8)	3	#16 (0.177 Inches)
6	19.1 (3/4)	4	13/64 Inches
8, 10	25.4 (1)	6	9/32 Inches
12	31.8 (1-1/4)	7	21/64 Inches

Reassembly

Before reassembling the valve, clean and inspect all parts. Key number locations are shown in figure 7. Refer to the Parts List section to obtain replacement parts.

⚠ WARNING

Do not lubricate parts when used in oxygen service, or where the lubrication is incompatible with the process media. Any use of lubricant can lead to the sudden explosion of media due to the oil/oxygen mixture, causing personal injury or property damage.

1. Insert the liner (key 2) into the valve body. A small amount of silicone grease applied to the outside surface of the liner will aid insertion of the liner. However, do not use grease if the valve is to be used for oxygen service.

In vacuum service applications, upon customer request, you may use Eccobond® 285/24LV bonding agent (Fisher part number G1414006992) to bond the liner to the valve. Though bonding is not required, use the lettered steps below when bonding the liner to the valve body. If a different agent is to be used, follow instructions furnished by the bonding agent manufacturer. In absence of instructions, consult your [Emerson sales office](#) or Local Business Partner.

- a. Roughen bonding surface of liner with a stiff wire brush. De-grease bonding surfaces of the liner and valve body with solvent.
 - b. Mix the two epoxy components thoroughly and spread a thin coat [approximately 0.38 mm (0.015 inches) thick] of the mixture over all bonding surfaces of the valve body and liner.
 - c. Insert the liner into the valve body. Align the liner shaft holes with valve body shaft holes. Remove excess bonding agent from shaft holes and exposed liner surfaces.
 - d. Insert the disc (key 3), thrust sleeve assemblies (key 6), and shaft (key 4) into the valve body. Be sure the thrust sleeve assemblies engage the liner recesses to ensure proper liner positioning. Rotate the disc to the closed position.
 - e. Lay the valve on one valve face and add weights to the other face to ensure a tight bond. Allow to cure for 24 hours. Then, proceed with the following reassembly steps.
2. Insert the thrust sleeve assemblies into the valve body. Be sure that the thrust sleeve assemblies enter the liner recesses to align the shaft holes, by temporarily inserting the shaft(s) (key 4).

3. A new disc and shaft should be installed if the taper pin holes have been widened by loosening of the taper pins (key 15).

Omit the following steps 4 through 8 if a new disc and shaft assembly is to be installed or if the old disc and shaft are to be reused. Use new taper pins whenever the disc has been removed.

CAUTION

If a new disc is required, a complete disc/shaft assembly must be purchased to avoid damage to valve parts. The old valve shaft cannot be used with a new disc.

If a new shaft (without disc) has been purchased, be sure to mark the shaft to indicate the disc position as shown in figure 2.

4. Making certain the taper pin holes are on the actuator side of the valve body, insert the disc into the valve body. Position the disc at the fully closed position.
5. Installing splined shaft:
 - a. If the old shaft is available, insert it into the valve body and disc. Line up the taper pin holes in the disc and shaft; measure and record the distance between the valve body and the splined end of the shaft. Remove the old shaft and insert the new, un-drilled shaft. Position the shaft so that there is the same distance between the valve body and the end of the shaft as noted above.
 - b. If installing a new shaft, insert the new shaft into the valve body and disc. Measure between the valve body and the splined end of the shaft. Make certain that the distance is correct to engage the actuator coupling lever.

Be certain that the flat spot or index mark on the end of the shaft is positioned as shown in figure 2.

6. Use a drill or center punch to mark the taper pin holes in the shaft. Remove the shaft and disc from the valve body.
7. Taper pins used in the 9500 valve shaft and disc are American Standard taper pins, as shown in table 5. Using the disc as a guide, drill taper pin holes through the shaft using drill size shown in table 5.
8. Use an American Standard taper pin reamer to ream the shaft holes. Be certain the reamer is of sufficient length for the disc hub thickness. Insert the shaft into the disc when reaming so the disc holes can be used as a gauge for reaming. Allow the reamer to just begin reaming the disc holes. This will ensure proper seating of the pins.
9. Install the disc and shaft into the valve body. Be sure the splined end of the shaft is on the actuator side of the valve body, that the direction of taper in the taper pin holes match, and that the flat spot or zero mark is positioned as shown in figure 2.
10. Using a metal sealing compound on the pins for a positive seal, insert the taper pins into the larger end of the taper pin holes. Drive the pins with a hammer to seat the pins.
11. Attach the thrust plates (key 9) with cap screws (key 10). When tightening the cap screws, do so in small increments, alternating from one cap screw to another and from one valve side to the other. Tighten the cap screws until the thrust plates contact the thrust sleeve assemblies snugly. Then rotate the cap screws enough to move the thrust plates 0.8 mm (1/32 inch) closer to the valve body.
12. Re-attach the actuator according to the steps in the Actuator Mounting section; then install the valve according to the steps in the Installation section.

Actuator Mounting

1. Refer to the appropriate actuator instruction manual to determine the desired actuator mounting style and position. With the valve out of the line, mount the actuator on the valve per instructions in the actuator instruction manual.
2. To determine the fully closed disc position, measure the distances between the valve face and the top and bottom edges of the disc as shown in figure 2. The disc is at the fully closed position when the two measurements are equal. Rotate the disc slightly if necessary to make the measurements equal.
3. Refer to figure 6 and locate the view that depicts the mounting style and position that is being used. In the appropriate view on the right of figure 6, note the positions of the index marks on the end of the valve shaft and actuator lever. For all positions and styles with 90-degree disc rotation, the shaft index mark is to be aligned with the appropriate lever index mark as shown in figure 6. This is also true for push-down-to-open action with 60-degree maximum disc rotation. However, for push-down-to-close action with 60-degree maximum disc rotation, the appropriate lever index mark must be offset one or two spline teeth counterclockwise from the shaft index mark.

Refer to the appropriate actuator instruction manual for instructions covering attaching the lever and adjusting the turnbuckle. For FISHTAIL discs, be certain that the direction of rotation will be such that the tail of the disc (see figure 2) will rotate into the downstream side of the valve.

Changing Disc Rotation and Action

Disc rotation can be changed from 0-90 degrees or vice versa by changing travel stops in the actuator and, if necessary, changing the position of the lever on the splined valve shaft. Action can be changed from push-down-to-open to push-down-to-close by removing the actuator and remounting it in the alternate mounting style. Refer to the appropriate actuator instruction manual for assistance in disassembly and reassembly to change travel stops and for instructions to change mounting style.

Note

Action for valves using a splined valve shaft can also be changed, without changing mounting style, by repositioning the actuator lever on the valve shaft. For FISHTAIL discs, it will be necessary to rotate the disc 180 degrees so that the tail of the disc will rotate into the downstream side of the valve.

Use the following procedure.

1. Refer to the appropriate actuator instruction manual for assistance in disconnecting and removing the actuator lever. Avoid disturbing the actuator turnbuckle adjustment, if possible.
2. If the valve disc is a FISHTAIL disc, rotate the disc 180 degrees from the original position.
3. Position the disc in its fully closed position. To ensure that disc is fully closed, measure equal distances between valve face and top and bottom of the disc as shown in figure 2 or check to be sure that the flat spot or index mark on the valve shaft is in top-dead-center or bottom-dead-center in relation to the valve.

▲ WARNING

To avoid personal injury, keep hands away from the actuator rod in the following procedure.

4. Note the position of the valve shaft index mark. Index mark alignments for reversed action are not shown in figure 6. To determine proper index mark alignment, proceed as follows:
 - a. Stroke the actuator to the valve-closed end of travel and retain that position while performing the next step.
 - b. Keeping hands away from the actuator rod, hold the actuator lever up to the valve shaft so that the lever end is in line with the actuator rod end bearing. The lever index mark that is most nearly in line with the valve shaft index mark is the index mark that must be used during reassembly. If changing to push-down-to-close action with 60-degree operation, the lever index mark will be offset 1 spline tooth from the valve shaft index mark for 12.7 through 19.1 mm (1/2 through 3/4-inch) valve shafts and 2 spline teeth from the valve shaft index mark for 25.4 and 31.8 mm (1 and 1-1/4 inch) valve shafts. This offset must be maintained during reassembly.
5. Record the alignment determined in step 4, remove the actuator lever, and shut off operating pressure to actuator.
6. Reassemble the lever to the actuator and adjust the actuator travel, if necessary, referring to the steps in the appropriate actuator instruction manual. Be sure to use the index mark alignment determined above rather than those shown in figure 6.

Figure 6. Splined-Shaft Index Mark Alignment for Standard Mounting Position-Valve Action Combinations

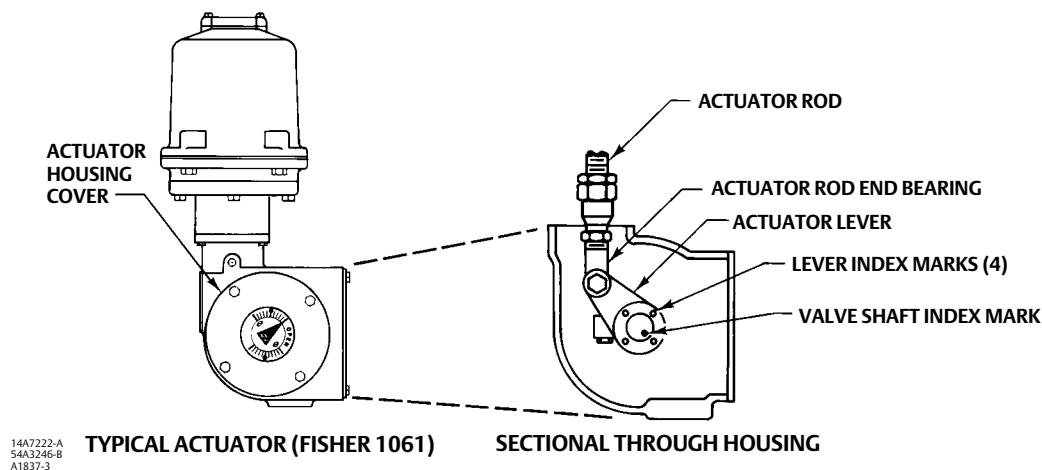

DISK	ACTUATOR		② VALVE CLOSED POSITION	③ MOUNTING POSITION 1	③ MOUNTING POSITION 2	③ MOUNTING POSITION 3	③ MOUNTING POSITION 4	
	MOUNTING	STYLE						
FISHTAIL	RIGHT-HAND MOUNTING (VIEWED FROM VALVE INLET)	STYLE A PUSH-DOWN-TO-OPEN 60- OR 90-DEG OPERATION	FLOW →					
		STYLE B PUSH-DOWN-TO-CLOSE 90-DEG OPERATION ①	FLOW →					
	LEFT-HAND MOUNTING (VIEWED FROM VALVE INLET)	STYLE C PUSH-DOWN-TO-CLOSE 90-DEG OPERATION ①	← FLOW					
		STYLE D PUSH-DOWN-TO-OPEN 60- OR 90-DEG OPERATION	← FLOW					
CONVENTIONAL	RIGHT OR LEFT-HAND MOUNTING (VIEWED FROM VALVE INLET)	STYLE A OR D PUSH-DOWN-TO-OPEN 60- OR 90-DEG OPERATION	← FLOW →					
		STYLE B OR C PUSH-DOWN-TO-CLOSE 90-DEG OPERATION ①	← FLOW →					

54A3246-B
B1054-3*

- ① FOR 60-DEGREE OPERATION WITH PUSH-DOWN-TO-CLOSE ACTION (EXTENDING ACTUATOR ROD CLOSSES VALVE), ROTATE ACTUATOR LEVER COUNTERCLOCKWISE SO THAT LEVER INDEX MARK IS OFFSET 1 SPLINE TOOTH FROM VALVE SHAFT INDEX MARK FOR ½ THROUGH ¾ INCH VALVE SHAFTS AND 2 SPLINE TEETH FROM VALVE SHAFT INDEX MARK FOR 1 INCH AND LARGER VALVE SHAFTS.
- ② CURVED ARROWS INDICATE ROTATION REQUIRED TO OPEN VALVE (COUNTERCLOCKWISE WHEN VIEWED FROM ACTUATOR SIDE OF VALVE).
- ③ ARROWS INDICATE DIRECTION OF ACTUATOR ROD TRAVEL REQUIRED TO OPEN VALVE.

Parts Ordering

A serial number is assigned to each valve body and stamped on the nameplate. Always refer to the serial number when corresponding with your [Emerson sales office](#) or Local Business Partner regarding spare parts or technical information. When ordering replacement parts, also specify the complete 11-character part number from the parts list information.

⚠ WARNING

Use only genuine Fisher replacement parts. Components that are not supplied by Emerson Automation Solutions should not, under any circumstances, be used in any Fisher valve, because they may void your warranty, might adversely affect the performance of the valve, and could cause personal injury and property damage.

Parts List

Key	Description	Part Number	Key	Description	Part Number
				CL300	
				NPS 2	F65117K0012
				NPS 3	F61929K0012
				NPS 4	F65480K0012
				NPS 6	F65493K0012
				NPS 8	F65484K0012
				NPS 10	F66225K0012
				NPS 12	F63606K0012
				S20910	
				CL125/150	
				NPS 2	L17986K0042
				NPS 3	L17987K0032
				NPS 4	L17988K0042
				NPS 6	L17989K0032
				NPS 8	L17990K0032
				NPS 10	L17991K0022
				NPS 12	L17992K0032
				CL300	
				NPS 2	F65117K0022
				NPS 3	F61929K0022
				NPS 4	F65480K0022
				NPS 6	F65493K0022
				NPS 8	F65484K0022
				NPS 10	F66225K0022
				NPS 12	F63606K0022
				S31600 (316 stainless steel)	
				1083 NPS 2	18A5865X022
				1083 NPS 3	18A5866X022
				1083 NPS 4	18A5867X022
				1083 NPS 6	18A5868X022
				CL125/150	
				NPS 2	L17986K0032
				NPS 3	L17987K0022
				NPS 4	L17988K0032
				NPS 6	L17989K0022
				NPS 8	L1799035072
				NPS 10	L1799135072
				NPS 12	L17992K0022
1	Valve Body				
	If you need a valve body as a replacement part, order by valve size, serial number, and desired material.				
2*	Liner Assy				
	Nitrile				
	NPS 2	F3897005562			
	NPS 3	F3897105562			
	NPS 4	F3897205562			
	NPS 6	F3897305562			
	NPS 8	F3897405562			
	NPS 10	F3897505562			
	NPS 12	F3897605562			
	PTFE/CR (Cloroprene)				
	NPS 2	F3587505452			
	NPS 3	F3587905452			
	NPS 4	F3588005452			
	NPS 6	F3581005452			
	NPS 8	F3588105452			
	NPS 10	F3588205452			
	NPS 12	F3588305452			
3	Disc				
4*	Shaft				
	S17400 (17-4 PH SST)				
	CL125/150				
	NPS 2	L17986K0012			
	NPS 3	L17987K0012			
	NPS 4	L17988K0012			
	NPS 6	L17989K0012			
	NPS 8	L17990K0012			
	NPS 10	L17991K0012			
	NPS 12	L17992K0012			

Key	Description		Key	Description	
6*	Sleeve/Bushing Assy (2 req'd)		9	Plate, Thrust (2 req'd)	
	Stainless Steel/PTFE		10	Screw,Cap, hex hd (4 req'd)	
	CL150 - CF8M body		15*	Taper Pin (2 req'd)	
	NPS 2	19A9333X022		S31600 (316 SST)	
	NPS 3	19A9335X022		NPS 2	F1368135072
	NPS 4	19A9337X022		NPS 3	G1194435072
	NPS 6	19A9339X022		NPS 4	G1194235072
	NPS 8	19A9347X012		NPS 6	G1194035072
	NPS 10	19A9349X012		NPS 8	G1193835072
	NPS 12	19A9351X012		NPS 10	G1329135072
	CL300 - CF8M body			NPS 12	H1374835072
	NPS 2	19A9334X022		S17400 (17-4 PH)	
	NPS 3	19A9336X022		NPS 2	F1368135362
	NPS 4	19A9338X022		NPS 3	G1194435362
	NPS 6	19A9340X022		NPS 4	G1194235362
	NPS 8	19A9348X012		NPS 6	G1194035362
	NPS 10	19A9350X012		NPS 8	G1193835362
	NPS 12	19A9352X012		NPS 10	G1329135362
	Steel/PTFE			NPS 12	H1374835362
	CL125/150 - Iron/steel body			S20910	
	NPS 2	19A9333X012		NPS 2	F13681K0022
	NPS 3	19A9335X012		NPS 3	G11944K0032
	NPS 4	19A9337X012		NPS 4	G11942K0012
	NPS 6	19A9339X012		NPS 6	G11940K0022
	NPS 8	19A9341X012		S20910	
	NPS 10	19A9343X012		NPS 8	G11938K0032
	NPS 12	19A9345X012		NPS 10	G13291K0012
	CL300 - steel body			NPS 12	H13748K0032
	NPS 2	19A9334X012	16	Nameplate	
	NPS 3	19A9336X012	17	Drive Screw, steel (2 req'd)	
	NPS 4	19A9338X012	19	Flow Tag, stainless steel (FISHTAIL disc only)	
	NPS 6	19A9340X012	21	FISHTAIL Disc Tag (FISHTAIL disc only)	
	NPS 8	19A9342X012	22	Flange Tag (not shown)	
	NPS 10	19A9344X012	26	Seal & Wire (not shown)	
	NPS 12	19A9346X012	130	Clamp, stainless steel	
			131	Bounding strap assembly	
			132	Flange Adapter (not shown) (2 req'd)	

Figure 7. Fisher 9500 Valve Body Assembly

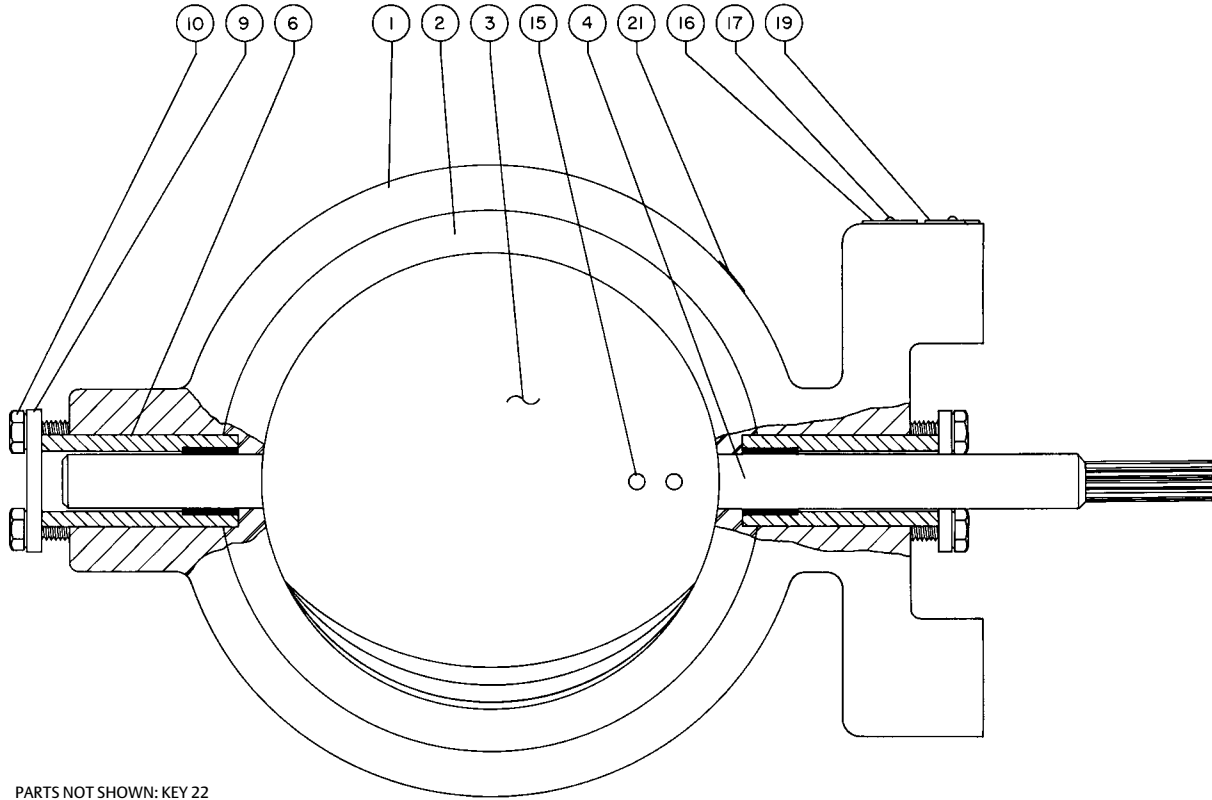

PARTS NOT SHOWN: KEY 22
G34171-B

Neither Emerson, Emerson Automation Solutions, nor any of their affiliated entities assumes responsibility for the selection, use or maintenance of any product. Responsibility for proper selection, use, and maintenance of any product remains solely with the purchaser and end user.

Fisher and FISHTAIL are marks owned by one of the companies in the Emerson Automation Solutions business unit of Emerson Electric Co. Emerson Automation Solutions, Emerson, and the Emerson logo are trademarks and service marks of Emerson Electric Co. All other marks are the property of their respective owners.

The contents of this publication are presented for informational purposes only, and while every effort has been made to ensure their accuracy, they are not to be construed as warranties or guarantees, express or implied, regarding the products or services described herein or their use or applicability. All sales are governed by our terms and conditions, which are available upon request. We reserve the right to modify or improve the designs or specifications of such products at any time without notice.

Emerson Automation Solutions
Marshalltown, Iowa 50158 USA
Sorocaba, 18087 Brazil
Cernay 68700 France
Dubai, United Arab Emirates
Singapore 128461 Singapore

www.Fisher.com

