

BIFFI MORIN S SERIES ACTUATORS

Stainless steel spring return and double acting pneumatic quarter-turn actuators
Output torques to 240,000 lb.in.



FEATURES AND BENEFITS

- Innovative stainless steel construction provides superior internal and external corrosion resistance.
- Scotch yoke design using precision bearings eliminates dead band in the yoke mechanism, providing the greatest torque output at the beginning and end of stroke.
- High strength 17-4PH stainless steel output shaft transmits torque and gives long service life.
- Heat-treated stainless steel thrust pin and rollers transfer piston force to yoke to reduce friction for longer life and more efficient torque transmission.
- Bi-directional travel stops provide accurate valve rotation adjustment.
- PTFE piston bearings, piston rod bushings and output shaft bushings provide longer life, reduce maintenance and require no lubrication.
- Universal design position indicator and pointer allows for either parallel or perpendicular mounting.
- Stainless steel construction allows proximity switches to be direct-mounted in the actuator housing, eliminating the need to mount bracket and cam assemblies on top.
- NAMUR drive slot maintains a compact assembly for accessory-driven components with no couplings necessary.
- Available in symmetrical and canted yoke design to suit application.
- Spring return model design requires no special tools to disarm springs safely and easily, reducing down time.

GENERAL APPLICATIONS

For remote control of any quarter-turn application: ball, butterfly, rotary plug or damper style valves, etc. To be used in chemical process, food and beverage, iron and steel, off-shore marine, pharmaceutical, power, oil and gas, pulp and paper, and textile industries.

TECHNICAL DATA

Supply pressure:	40 to 160 psig (see torque chart)
Supply medium:	Air or any gas compatible with materials of construction
Temperature rating	
Standard range:	-20°F to 210°F
Optional range:	-65°F to 300°F
Angular rotation:	90 degrees (adjustable between 82 and 98 degrees)
Mounting pattern:	ISO 5211
Protection:	IP66; IP68 (optional)
Certification:	SIL3 rated

BIFFI MORIN S SERIES ACTUATORS

DESIGNED WITH A HEART OF STAINLESS STEEL

Stainless steel yoke

The heart of any scotch yoke actuator is the yoke. S series actuators use 17-4PH stainless for this critical area as standard. The yoke is the mechanism used to convert linear force to torque. This area is most often where the life of the actuator is controlled.

Principles of construction

Using high quality materials of construction and modern rugged design concepts provides the standard for high quality, low cost valve actuation.

The S actuator housings are all machined from 316 stainless steel castings. This produces a rugged, low cost product through reduced machining time and by eliminating wasteful excess material.

Any components that rotate or slide during operation, such as the high strength stainless steel output shaft, stainless steel piston rod, stainless steel thrust pin or the stainless steel piston, are all supported by replaceable friction reducing bearings.

Bi-directional travel stops

Adjustable stops on each end cap provide the flexibility of accurate valve rotation positioning at the end of the 'open' and 'close' stroke. Both stops are located on the cylinder centerline, the optimal position to maximize travel adjustment and eliminate any detrimental side loading on the travel stops. Adjustable from 82° to 98°.

Ingress protection

Standard IP66. Optional IP68.

Spring designed for safety

All spring return models incorporate a 'man-safe' spring design that allows the actuator to be safely assembled and disassembled in the field without the need for special tools. The integral tie rods are bored and tapped to provide a means of loading and unloading the spring in a safe and convenient manner.

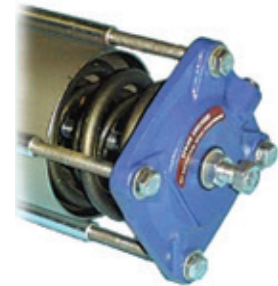

SYMMETRICAL SCOTCH YOKE TORQUE CHARACTERISTICS

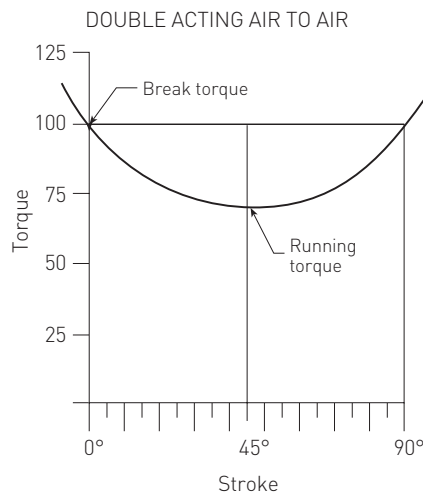
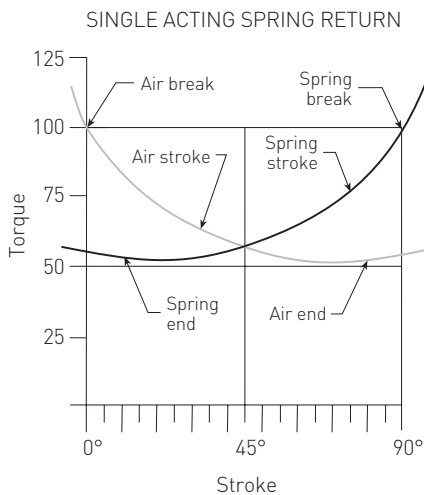

AVAILABLE OPTIONS

- Jackscrew override
- Hydraulic override
- Full stroke adjustment
- Proximity preparation
- Lockout device
- Partial stroke test

BIFFI MORIN S SERIES ACTUATORS
MATERIALS OF CONSTRUCTION

DOUBLE ACTING - MODELS 003 TO 100

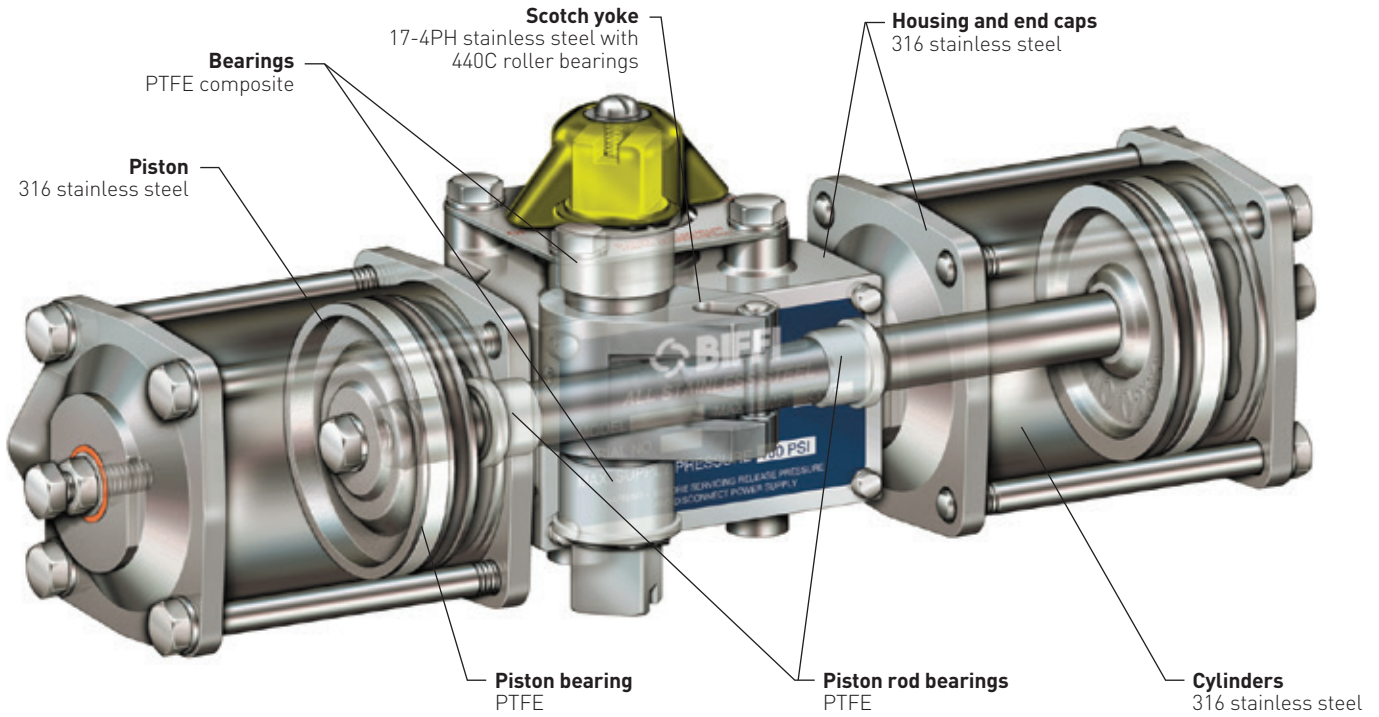

DOUBLE ACTING - MODELS 135 TO 1150

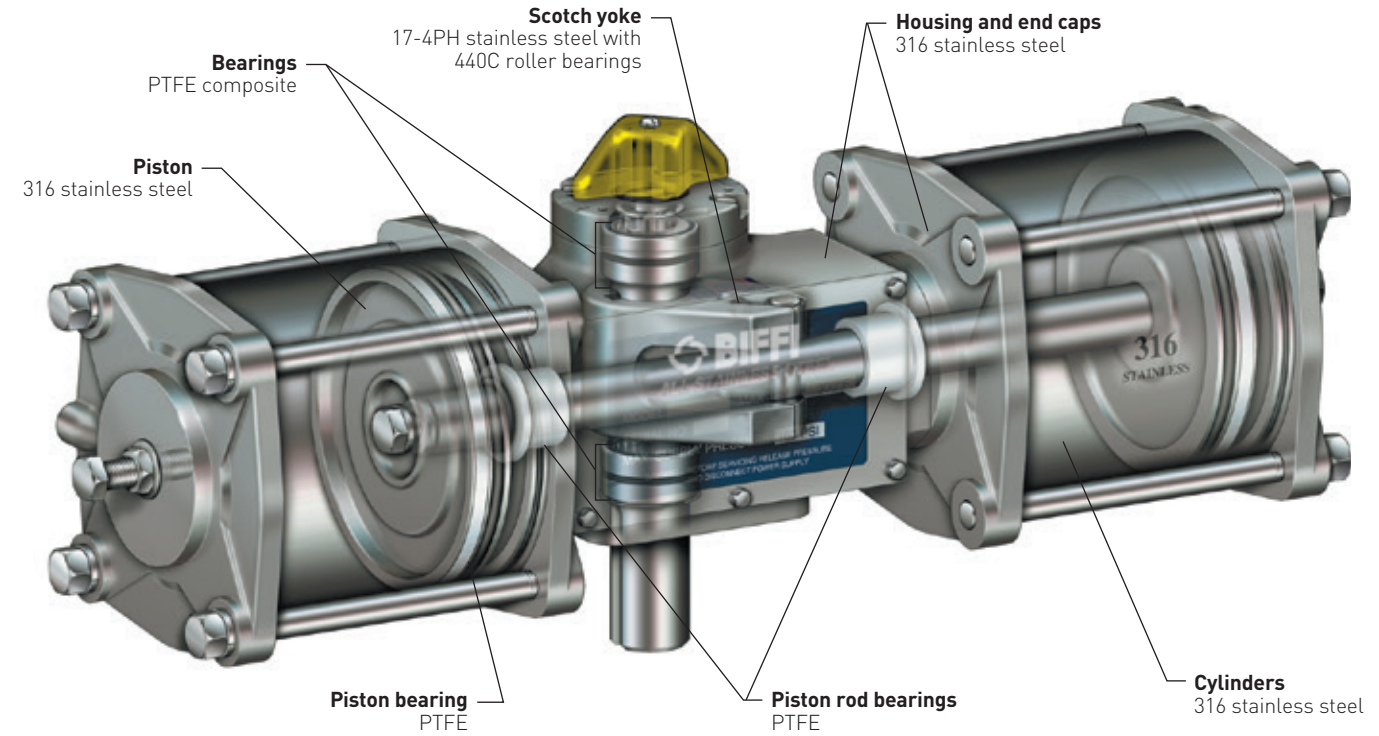

SYMMETRICAL AND CANTED YOKES

It's about fitting the torque curve of the actuator to the valve . . .

It's about lower cost, lighter weight, smaller actuators . . .

It's about CHOICE . . .

Symmetric

Symmetrical yoke design offers the standard torque curve seen most often in relation to scotch yoke actuators. It offers the increased torque advantage at both ends of the 90° stroke as shown on the blue curve below. This torque curve covers most quarter-turn applications.

Canted

Canted yoke design moves the torque curve to where it's needed most, gaining as much as 35% more break and reset torque for the same size actuator. The canted yoke curve is shown in red below. Canted yoke actuators allow selection of smaller, lighter, and less expensive actuator packages.

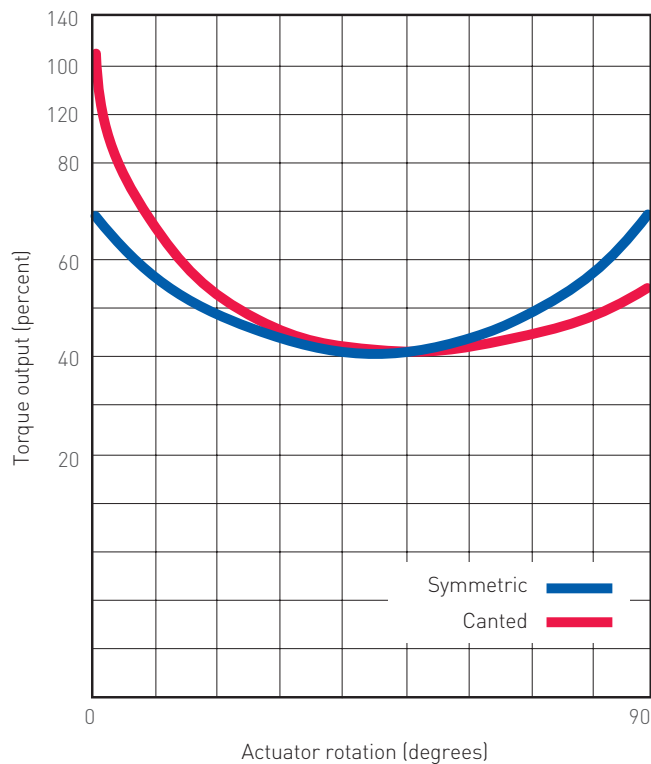
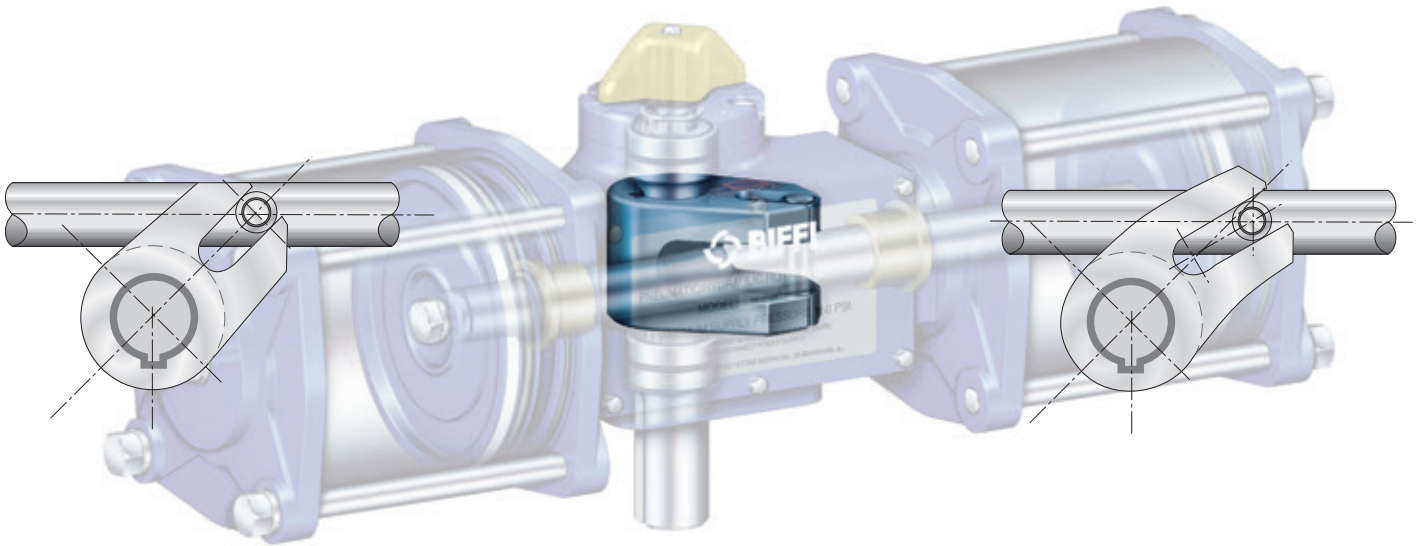

BIFFI MORIN S SERIES ACTUATORS

OPTIONS

MANUAL OPTIONS

To provide the actuation package best suited for your application, we offer a full range of manual accessories.

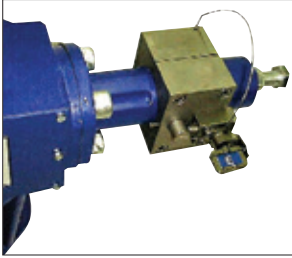

Partial stroke test device (PSTD)

Provides a method of testing ESD packages without shutdown.



Lockout

Integral lockout allows safe shutdowns for maintenance and isolation of systems.

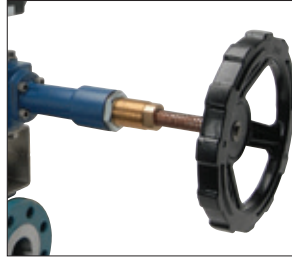

Jackscrew override (JSO)

Manual operation when power is lost. Simple and effective.



Hydraulic override (MHP)

Manual operation when power is lost. Includes speed controls.



AWWA

Tested per American Waterworks Association C540. Available for pneumatic or water service operation.

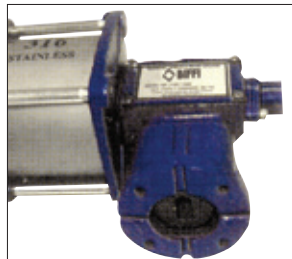

Direct mounting cast adapters

Many valve top works covered, including some ISO mounting. Assures economic but correct mounting alignment.

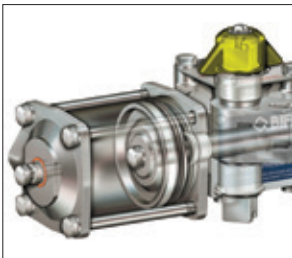

Full stroke adjuster

Provides mechanical control of maximum and/or minimum valve stroke.

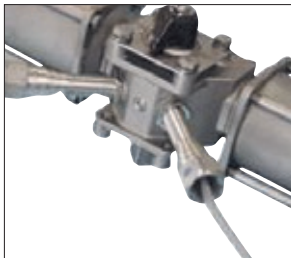

Proximity switch preparation

Allows installation of cartridge style proximity switches. Leaves top works open for mounting of other devices.

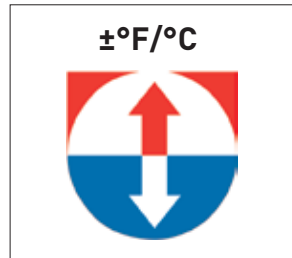

High or low temperature ratings

Standard rating of -20°F to 210°F [-29°C to 99°C] covers most applications. Optional ratings down to -65°F [-54°C] and up to 300°F [149°C].

BIFFI MORIN S SERIES ACTUATORS

MECHANICAL DATA

MECHANICAL DATA

Actuator model	Closing torque at 80 psig		Number of pistons	Cylinder bore (inch)	Stroke (inch)	Volume ⁽¹⁾ (cubic in) 90° stroke	Cycle time (seconds) 90° stroke	Weight (lbs.)
	Symmetrical	Canted						
Double acting								
003	345	-	1	2.250	1.5	6	0.3	5
006	600	-	1	2.750	2	12	0.5	10
012	1380	-	2	2.750	2	23	0.7	12
023	2300	2990	1	4.375	3	45	1.0	27
036	3960	5148	1	5.438	3	70	1.5	30
050	5000	6500	1	6.250	3	92	2.2	36
059	5900	7670	2	4.375/5.438	3	112	2.4	39
072	7920	*9009	2	5.438	3	137	2.5	37
100	10000	**9750	2	6.250	3	182	3.0	46
135	14175	18428	1	8.250	5	267	4.5	165
210	23100	30030	1	10.250	5	413	5.0	185
270	28350	36855	2	8.250	5	526	6.0	210
345	36225	*41206	2	8.250/10.250	5	671	7.0	234
370	37000	51469	1	12.250	6	707	8.0	390
420	42000	**40950	2	10.250	5	816	8.5	257
575	63825	82973	1	15.500	6	1132	9.5	519
740	77700	101010	2	12.250	6	1395	10.0	530
945	101115	**98587	2	12.250/15.500	6	1820	11.0	653
1150	120750	***98110	2	15.500	6	2245	12.0	775
1480	148000	192400	2	12.250	12	2744	20.0	850
2380	238000	**232050	2	15.500	12	4444	24.0	1050

* at 70 psig; ** at 60 psig; *** at 50 psig; **** at 90 psig

Spring return

003	105	-	1	2.250	1.5	6	0.3	6
006	221	-	1	2.750	2	12	0.5	11
012	462	-	2	2.750	2	23	0.7	14
023	800	1120	1	4.375	3	45	1.0	34
036	1260	1764	1	5.438	3	70	1.5	42
046	1600	2083	2	6.250	3	92	2.0	43
058	*1600	*2240	2	5.438/4.375	3	112	2.3	54
059	1890	2646	2	4.375/5.438	3	112	2.4	54
072	2500	3500	2	5.438	3	137	2.5	55
100	3500	4900	2	6.250	3	182	3.0	64
135	5670	7938	1	8.250	5	267	4.5	210
210	8085	11319	1	10.250	5	413	5.0	235
270	10395	14553	2	8.250	5	526	6.0	250
344	12637	17692	2	10.250/8.250	5	671	7.0	315
345	****13760	****19264	2	8.250/10.250	5	671	7.0	315
370	14893	20850	1	12.250	6	707	8.0	540
420	15435	21609	2	10.250	5	816	8.5	379
575	21131	27512	1	15.500	6	1132	9.5	779
740	29785	41699	2	12.250	6	1395	10.0	704
944	*27713	*38798	2	15.500/12.250	6	1820	11.0	871
945	32303	45224	2	12.250/15.500	6	1820	11.0	871
1150	42263	59168	2	15.500	6	2245	12.0	1082
1480	51800	72520	2	12.250	12	2744	20.0	1650
2380	83300	116620	2	15.500	12	4444	24.0	1850

NOTES

1. Air consumption:

Cubic inches shown in chart represent actual free air volume in cylinder between piston and end cap when furthest apart.

Air consumption will vary depending on supply pressure. To determine standard cubic feet per minute use the following formula:

$$\left(\frac{\text{Vol. in}^2}{1728} \right) \left(\frac{\text{Supply air barg} + 14.7}{14.7} \right) \left(\text{Strokes/min} \right)$$

Example: Calculate SCFM for model 023 double acting using 80 psig air supply and 5 strokes/minute.

$$\text{SCFM} = \left(\frac{45}{1728} \right) \left(\frac{80 + 14.7}{14.7} \right) (5) = 0.84$$

2. Cycle times shown represent average time to stroke 90 degrees using standard pilot valves and should be used as a guide only. Cycle times can be increased or decreased dramatically by using speed controls, oversized pilot valves or quick exhaust valves.

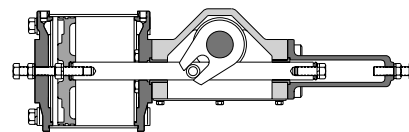

TYPICAL SECTION - double acting/one piston

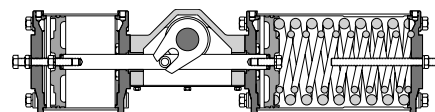

TYPICAL SECTION - spring return/two pistons

BIFFI MORIN S SERIES ACTUATORS

DIMENSIONS

MODELS 012, 046, 058, 059, 072 AND 100

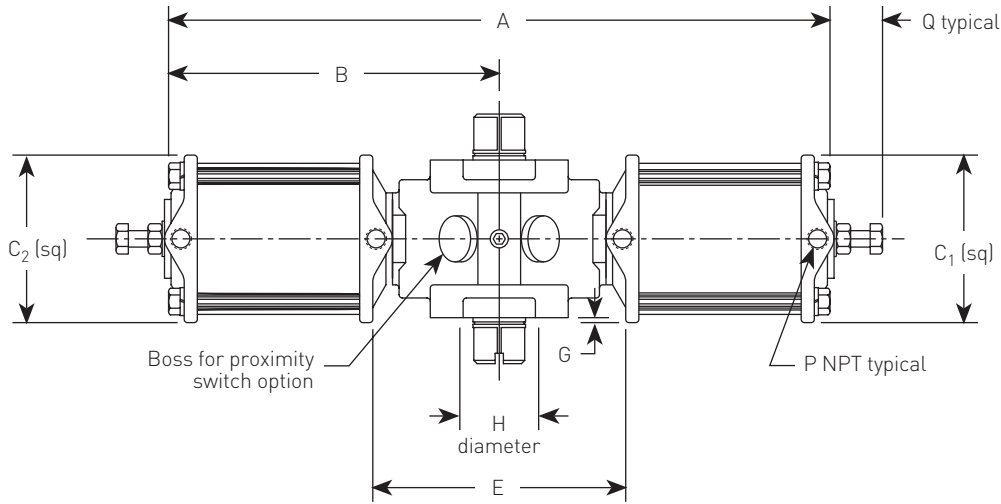

MODELS 003, 006, 023, 036 AND 050

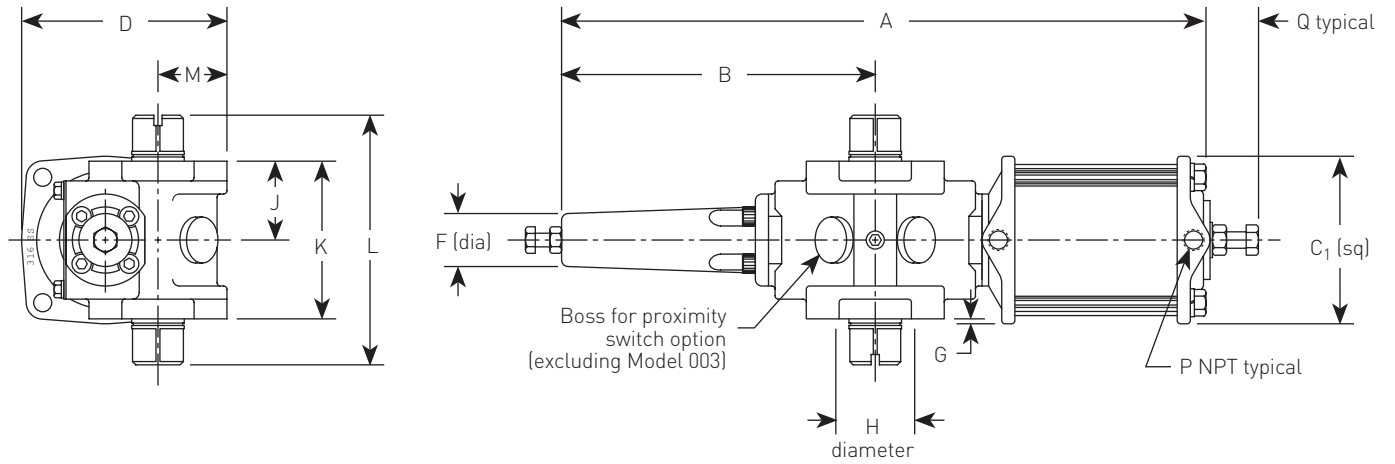

NOTES

1. Shown without pointer for clarity.
2. For mounting dimensions, refer to pages 11 and 12.

BIFFI MORIN S SERIES ACTUATORS

DIMENSIONS

DIMENSIONS (inches) DOUBLE ACTING

Model	A	B	C ₁	C ₂	D	E	F	G	H	J	K	L	M	P	Q
003DA	9.06	3.50	2.69	-	3.06	-	0.75	-	1.00	1.37	2.75	3.25	1.00	1/8	0.62
006DA	12.34	5.97	3.18	-	3.91	-	1.00	0.10	1.38	1.50	3.00	4.75	1.31	1/8	1.00
012DA	12.74	6.37	3.18	3.18	3.91	4.81	-	0.10	1.38	1.50	3.00	4.75	1.31	1/8	1.00
023DA	18.60	8.81	4.81	-	5.78	-	1.43	0.25	1.75	2.16	4.31	6.69	1.88	1/4	1.15
036DA	18.48	8.81	5.81	-	6.28	-	1.43	0.75	1.75	2.16	4.31	6.69	1.88	1/4	1.25
050DA	18.49	8.81	7.13	-	6.94	-	1.43	1.41	1.75	2.16	4.31	6.69	1.88	1/4	1.25
059DA	19.40	9.66	4.81	5.81	6.66	6.34	-	0.75	1.75	2.16	4.31	6.69	2.25	1/4	1.00
072DA	19.33	9.67	5.81	5.81	6.28	6.38	-	0.75	1.75	2.16	4.31	6.69	1.88	1/4	0.83
100DA	19.35	9.68	7.12	7.12	6.94	6.38	-	1.41	1.75	2.16	4.31	6.69	1.88	1/4	0.75

DIMENSIONS (inches) SPRING RETURN

Model	A	B	C ₁	C ₂	D	E	F	G	H	J	K	L	M	P	Q
003SR	9.06	3.50	2.69	-	3.06	-	0.75	-	1.00	1.37	2.75	3.25	1.00	1/8	0.62
006SR	14.44	5.97	3.18	-	3.91	-	1.00	0.10	1.38	1.50	3.00	4.75	1.31	1/8	1.00
012SR	14.84	6.37	3.18	3.18	3.91	4.55	-	0.10	1.38	1.50	3.00	4.75	1.31	1/8	1.00
023SR	21.82	8.81	4.81	-	5.78	-	1.43	0.25	1.75	2.16	4.31	6.69	1.88	1/4	1.25
036SR	23.51	8.81	5.81	-	6.28	-	1.43	0.75	1.75	2.16	4.31	6.69	1.88	1/4	1.25
046SR	22.80	9.79	4.81	4.81	5.93	6.24	-	0.25	1.75	2.16	4.31	6.69	1.88	1/4	1.25
058SR	22.79	9.73	5.81	4.81	6.66	5.58	-	0.75	1.75	2.16	4.31	6.69	2.25	1/4	1.25
059SR	24.44	9.66	4.81	5.81	6.66	5.44	-	0.75	1.75	2.16	4.31	6.69	2.25	1/4	1.25
072SR	24.37	9.67	5.81	5.81	6.28	5.99	-	0.75	1.75	2.16	4.31	6.69	1.88	1/4	1.25
100SR	24.38	9.68	7.12	7.12	6.94	5.99	-	1.41	1.75	2.16	4.31	6.69	1.88	1/4	1.25

BIFFI MORIN S SERIES ACTUATORS

DIMENSIONS

MODELS 270, 344, 345, 420, 740, 944, 945 AND 1150

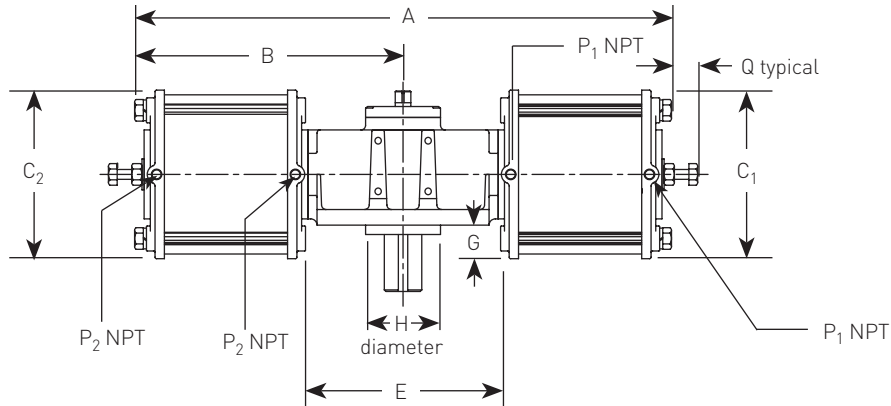

MODELS 135, 210, 370 AND 575

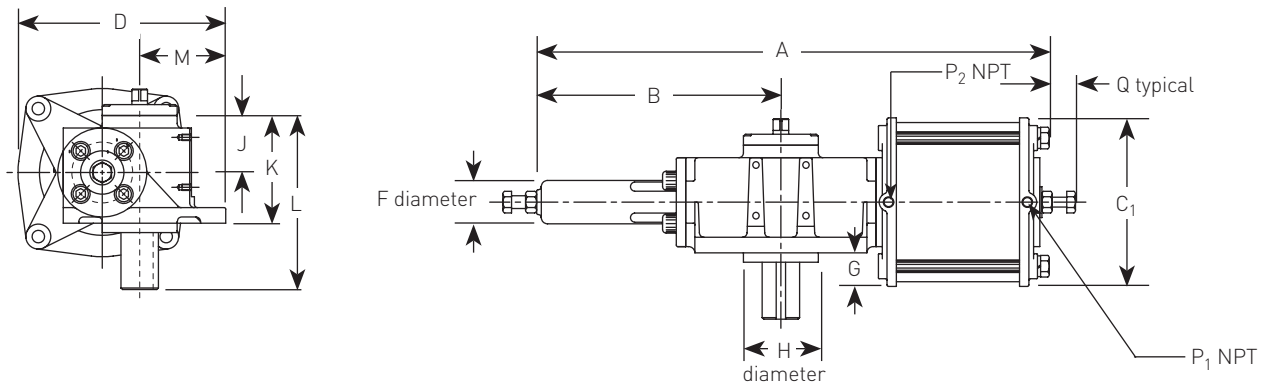

MODELS 1480 AND 2380

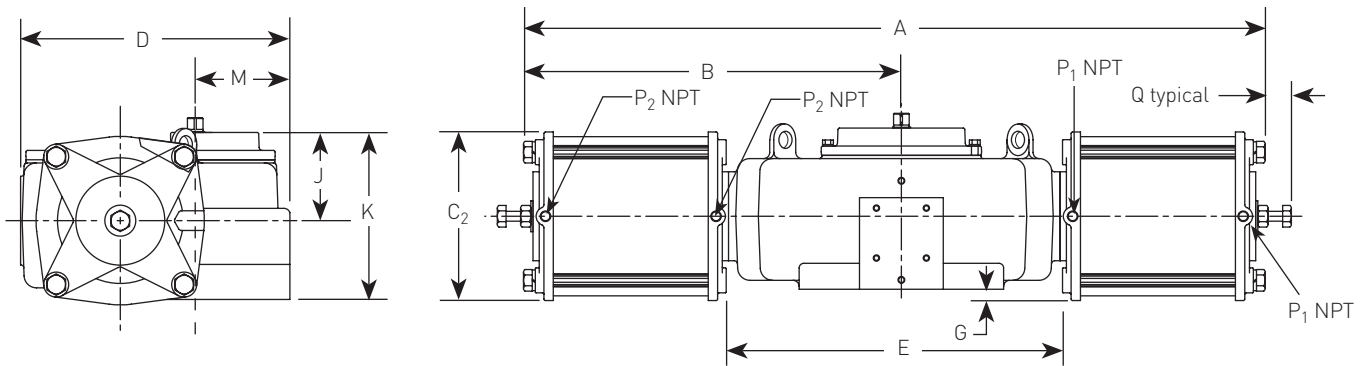

NOTES

1. Shown without pointer for clarity.
2. For mounting dimensions, refer to pages 11 and 12.

BIFFI MORIN S SERIES ACTUATORS

DIMENSIONS

DIMENSIONS (inches) DOUBLE ACTING

Model	A	B	C ₁	C ₂	D	E	F	G	H	J	K	L	M	P ₁	P ₂	Q
135DA	32.74	15.88	9.50	-	10.44	-	2.75	1.00	-	4.38	8.13	11.82	3.19	3/8	3/8	1.75
210DA	33.26	15.88	11.50	-	11.44	-	2.75	2.00	-	4.38	8.13	11.82	3.19	1/2	1/2	2.12
270DA	33.77	16.89	9.50	9.50	10.44	11.72	-	1.00	-	4.38	8.13	11.82	3.19	3/8	3/8	1.75
345DA	34.26	16.89	9.50	11.50	11.44	11.47	-	2.00	-	4.38	8.13	11.82	3.19	3/8	1/2	2.12
370DA	41.64	19.56	13.50	-	16.75	-	3.50	2.69	5.90	5.44	9.50	14.81	6.88	1/2	1/2	1.75
420DA	34.75	17.38	11.50	11.50	11.44	11.22	-	2.00	-	4.38	8.13	11.82	3.19	1/2	1/2	2.12
575DA	42.26	19.56	17.00	-	18.50	-	3.50	4.44	5.90	5.44	9.50	14.81	6.88	3/4	3/4	2.50
740DA	44.15	22.07	13.50	13.50	16.75	15.62	-	2.69	5.90	5.44	9.50	14.81	6.88	1/2	1/2	1.75
945DA	44.77	22.07	13.50	17.00	18.50	15.25	-	4.44	5.90	5.44	9.50	14.81	6.88	1/2	3/4	2.50
1150DA	45.39	22.69	17.00	17.00	18.50	14.88	-	4.44	5.90	5.44	9.50	14.81	6.88	3/4	3/4	2.50
1480DA	77.15	38.58	13.50	13.50	21.57	33.44	-	0.56	-	7.96	15.30	-	7.58	1/2	1/2	2.12
2380DA	78.39	39.20	17.00	17.00	22.08	32.69	-	1.18	-	7.96	15.30	-	7.58	3/4	3/4	2.67

DIMENSIONS (inches) SPRING RETURN

Model	A	B	C ₁	C ₂	D	E	F	G	H	J	K	L	M	P ₁	P ₂	Q
135SR	39.46	15.88	9.50	-	10.44	-	2.75	1.00	-	4.38	8.13	11.82	3.19	3/8	3/8	1.75
210SR	42.67	15.88	11.50	-	11.44	-	2.75	2.00	-	4.38	8.13	11.82	3.19	1/2	1/2	2.12
270SR	40.57	16.99	9.50	9.50	10.44	10.95	-	1.00	-	4.38	8.13	11.82	3.19	3/8	3/8	1.75
344SR	40.95	17.38	11.50	9.50	11.44	10.70	-	2.00	-	4.38	8.13	11.82	3.19	1/2	3/8	2.12
345SR	43.79	16.99	9.50	11.50	11.44	10.61	-	2.00	-	4.38	8.13	11.82	3.19	3/8	1/2	2.12
370SR	51.48	19.56	13.50	-	16.75	-	3.50	2.69	5.90	5.44	9.50	14.81	6.88	1/2	1/2	1.75
420SR	44.17	17.38	11.50	11.50	11.44	10.36	-	2.00	-	4.38	8.13	11.82	3.19	1/2	1/2	2.12
575SR	54.12	19.56	17.00	-	18.50	-	3.50	4.44	5.90	5.44	9.50	14.81	6.88	3/4	3/4	2.50
740SR	53.99	22.07	13.50	13.50	16.75	14.75	-	2.69	5.90	5.44	9.50	14.81	6.88	1/2	1/2	1.75
944SR	54.59	22.67	17.00	13.50	18.50	14.37	-	4.44	5.90	5.44	9.50	14.81	6.88	3/4	1/2	2.50
945SR	56.63	22.07	13.50	17.00	18.50	14.16	-	4.44	5.90	5.44	9.50	14.81	6.88	1/2	3/4	2.50
1150SR	57.22	22.69	17.00	17.00	18.50	13.79	-	4.44	5.90	5.44	9.50	14.81	6.88	3/4	3/4	2.50
1480SR	93.49	38.58	13.50	13.50	21.57	32.57	-	0.56	-	7.96	15.30	-	7.58	1/2	1/2	2.12
2380SR	94.70	39.20	17.00	17.00	22.08	31.61	-	1.18	-	7.96	15.30	-	7.58	3/4	3/4	2.50

BIFFI MORIN S SERIES ACTUATORS

DIMENSIONS

MODEL 003 - TOP AND BOTTOM OF HOUSING

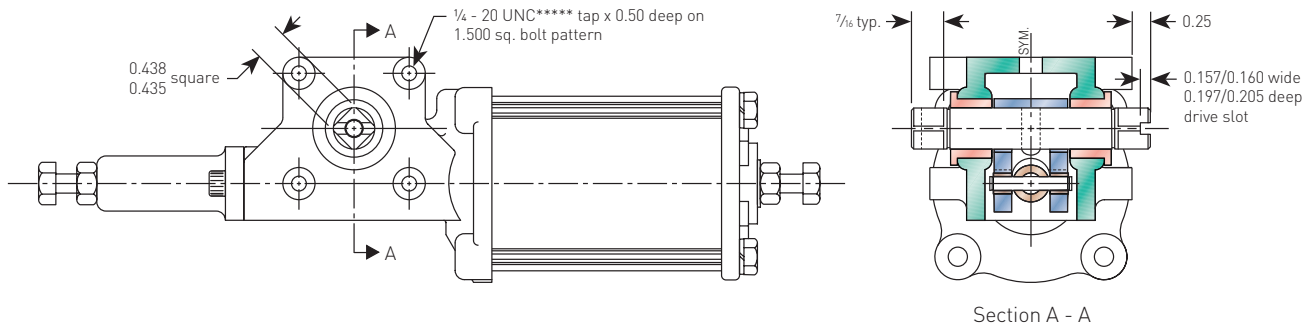

MODELS 006 TO 100 AND 144 - TOP AND BOTTOM OF HOUSING

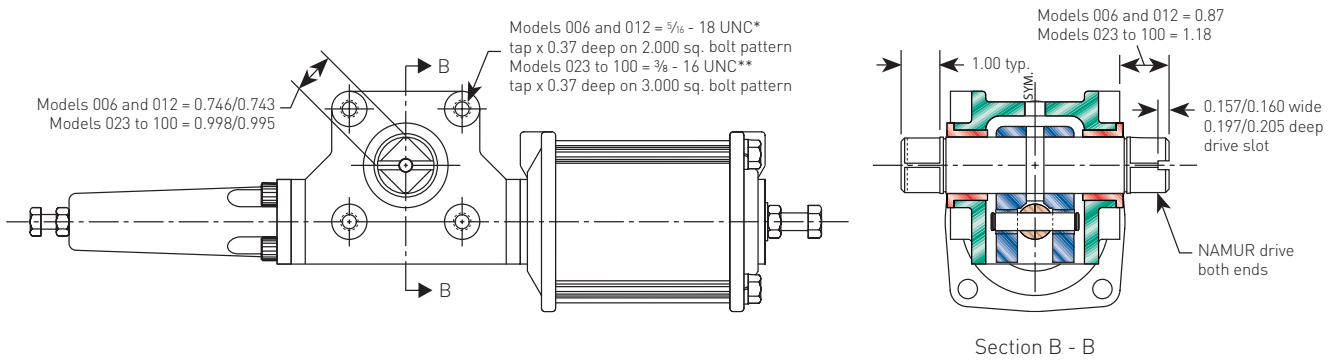

MODELS 135, 210, 270, 344, 345 AND 420 - BOTTOM OF HOUSING ISO 5211-F16

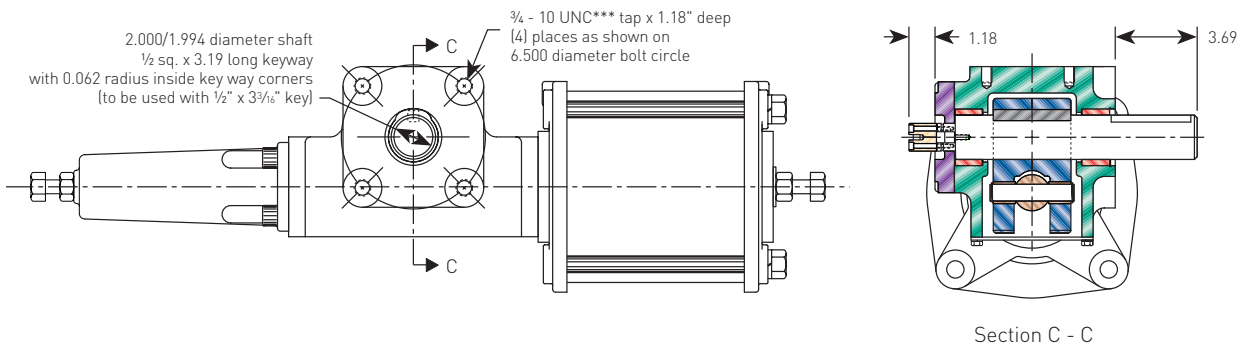

MODELS 135, 210, 270, 344, 345 AND 420 - TOP OF HOUSING - MOUNTING DETAILS

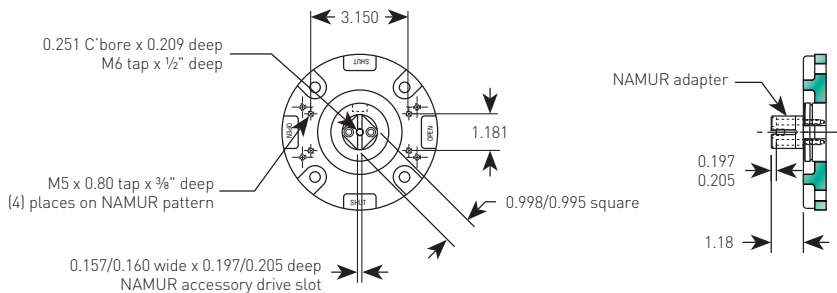

METRIC THREAD OPTION

Standard tap	Model number
* M8	006 and 012
** M10	023 to 100
*** M20	135 to 1150
**** M6	003

Replace 'U' with 'M' in order number designation (refer to page 13).

BIFFI MORIN S SERIES ACTUATORS

MOUNTING DETAILS

MODELS 370, 575, 740, 944, 945 AND 1150 - BOTTOM OF HOUSING ISO 5211-F30

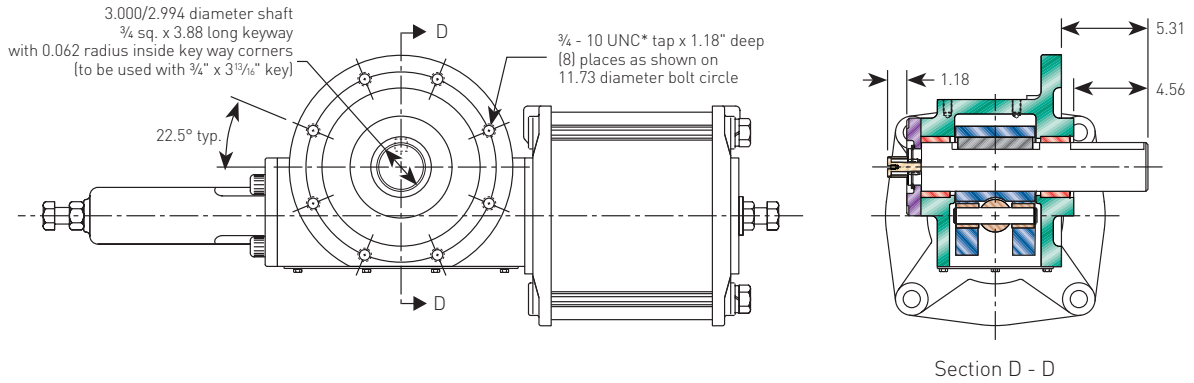

MODELS 370, 575, 740, 944, 945 AND 1150 - TOP OF HOUSING - MOUNTING DETAILS

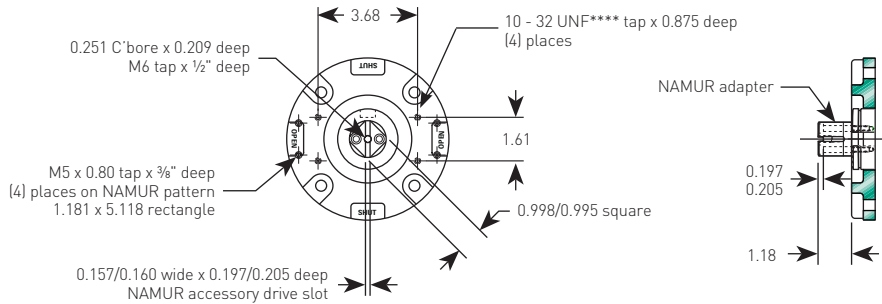

MODELS 1480 AND 2380 - BOTTOM OF HOUSING ISO 5211-F35

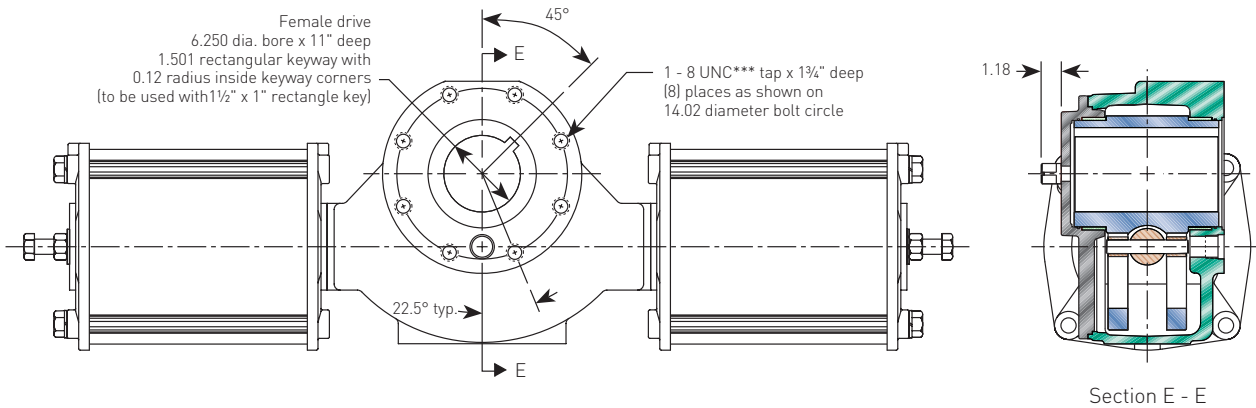

MODELS 1480 AND 2380 - TOP OF HOUSING - MOUNTING DETAILS

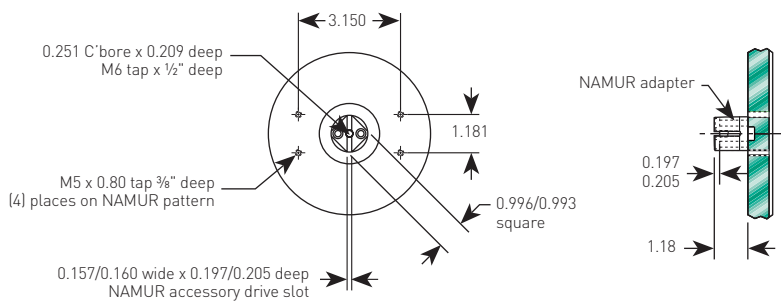

METRIC THREAD OPTION

Standard tap	Model number
* M20	370 and 575 to 1150
*** M30	1480 and 2380

Replace 'U' with 'M' in order number designation
(refer to page 13).

BIFFI MORIN S SERIES ACTUATORS

ORDERING INFORMATION

SELECTION GUIDE

Actuator model

S- Stainless steel

Actuator size Model code based on approximate torque of symmetrical double acting at 80 psig

270	003	058	344	945
	006	059	345	1150
	012	072	370	1480
	023	100	420	2380
	036	135	575	
	046	210	740	
	050	270	944	

Interface bolting

- U - UNC mounting threads
- M - Metric mounting threads

Yoke design

- (blank) - Symmetrical yoke
- C - Canted yoke

Function

- D - Double acting
- S - Spring return

Spring code

- 00 **00** - No spring - Double acting
- 04** - 40 pound spring
- 05** - 50 pound spring
- 06** - 60 pound spring

Etc. see Morin Torque Book for available springs

Spring return failure rotation

- 0 - No spring (double acting OR actuator rotates clockwise on loss of air)
- 1 - Actuator rotates counterclockwise on loss of air

Option

(blank) - No options (standard configuration)

See complete modules code listing

Note: Some codes can be used in combination. Indicate by "stacking" separated by "-". Consult factory for possible combinations combinations.

S- 270 U C - D 00 0 - JSO = Model number **S-270UC-D000-JSO**

HOW TO ORDER

1. Double acting example

Air supply: 80 psig

Break torque: 7,200 lb.in.

S-072U-D000

S Series

072 Model number

U UNC mounting threads

D000 Double acting

2. Spring return example

Air supply: 80 psig

Ending torque: 12,950 lb.in.

Fail rotation: clockwise

S-370U-S080

S Series

370 Model number

U UNC mounting threads

S080 Spring set

3. For all spring return models

Use air pressure to determine spring set

All spring sets ending with "0" fail clockwise (40, 50, 60, etc.)

All spring sets ending with "1" fail counterclockwise (41, 51, 61, etc.)



STAINLESS STEEL CONTROL MONITORS AND TRANSMITTERS*

Touch set cams in all control monitors are hand adjustable, spring loaded and self-locking providing quick calibration of position sensors. Terminal strips are pre-wired and color coded with generous working space for ease of use and extra wiring points for solenoid integration. All units are standard with multiple conduits for easy field wiring and accessory mounting. All AccuTrak™ and Quantum™ products utilize common bolt pattern for mounting to actuators and can be supplied with mounting hardware as needed. Low copper content aluminum enclosures (0.2% maximum copper content) insure robust performance in corrosive environments. Control transmitters utilize non-contact Hall Effect sensing technology and digital position transmission via 4-20 mA signal. Transmitters are available with both HART® and Foundation Fieldbus™ digital communication protocols.

NETWORK SOLUTIONS*

Intellis is a family of industrial control field Network Control Monitors which use embedded control systems to automate valves and link field I/O to the host PLC or DCS. Each monitor is assigned a unique address and accepts input/output signals from valve position sensors, solenoids and external alarm and control devices. Hall Effect sensors are utilized for valve position monitoring. Low-power Falcon solenoid valve provides integrated actuation control. Network interface modules Pacs allow communication via a protocol of choice. Westlock Intellis Network Control Monitors are available for linear or rotary applications in all area classifications.



INTELLIS CONTROL MONITOR

NOTES

* Stainless steel, AccuTrak, Quantum, Intellis Network Solutions and Positioners - please consult your sales representative for the availability of global certifications such as ATEX, IEC, GOST, CSA and InMetro for specific configurations in these product lines, as approvals may vary.



STAINLESS STEEL MODULATING PACKAGES FOR HARSH ENVIRONMENTS

S series stainless steel actuator with Westlock ICoT 6000 series stainless steel positioners



No linkage to wear, damage or miss-align, thus increasing accuracy and reliability of this package. Low air consumptions as a result of the precision lapped spool valve design allows for operational cost savings by reducing air compressor operation. The 6000 series is available with an optional integral 4 to 20 mA position transmitter for continuous feedback of position throughout full range of travel.

Area classification (NEC 500 and 504) for Class 1, Division 1, Groups C D, Class II & III, Division 1, Groups E, F, and G.

Auto Calibration offers quick and simple calibration that takes on a few minutes.



Position and signal input visible while in operation.

BIFFI MORIN S SERIES ACTUATORS

ALSO AVAILABLE

THE B AND C SERIES ACTUATORS

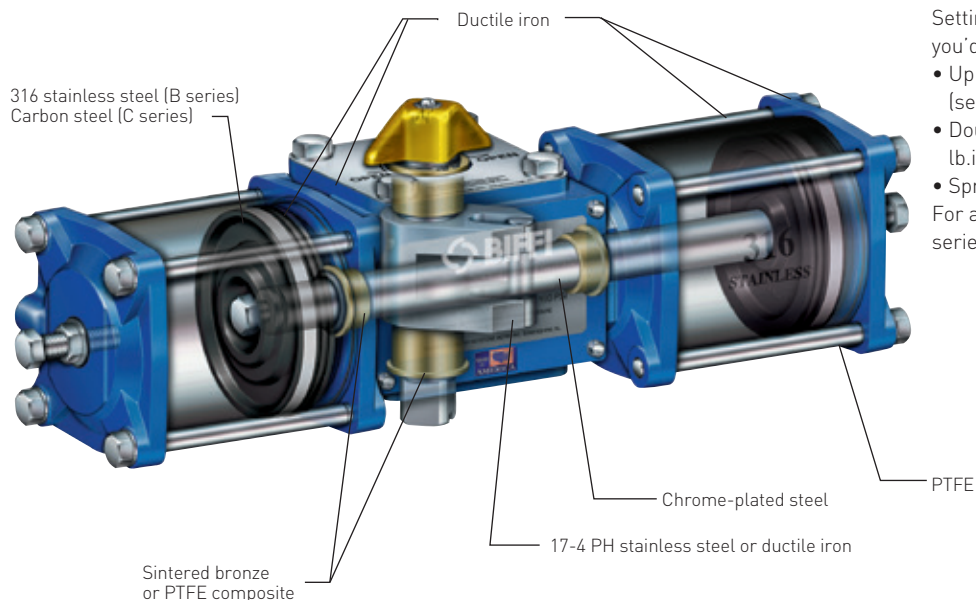

Setting a new standard in actuation at a price you'd expect from a commodity product.

- Up to 160 psig operating pressure (see torque chart).
- Double acting break torques to 1,400,000 lb.in.
- Spring end torques to 583,288 lb.in.

For additional information, refer to B and C series data sheet.

THE HP SERIES ACTUATOR



High pressure actuation with Xylan® coated carbon steel cylinders for superior corrosion resistance.

- Up to 2250 psi operating pressure (see torque chart).
- Double acting torques to 800,000 lb.in.
- Spring end torques to 400,000 lb.in.

For additional information, refer to HP Series data sheet.



Biffi reserves the right to change product designs and specifications without notice.

Biffi Italia S.r.L.

Località Caselle San Pietro, 420, 29017 Fiorenzuola d'Arda (PC) ITALY Ph: +39 (0)523 944 411 E-mail: biffi_italia@biffi.it www.biffi.it