

F02 QUARTER-TURN ELECTRIC ACTUATOR

INSTALLATION & MAINTENANCE INSTRUCTIONS



1. GENERAL SAFETY INSTRUCTIONS

1.1 INTENDED USE

The F02 electric actuators covered in this Instruction and Operating Manual are designed for the operation of any kind of quarter-turn industrial valves (i.e., ball, butterfly, plug and control valves) used in a wide range of applications ranging from heavy industrial, chemical, petrochemical plants, waterworks, water pipelines, waste paper plants and power plants to food, brewing and heating, ventilation, air conditioning, etc.

Biffi will not be liable for any possible damage or physical injury resulting from use in other than the designated applications or by lack of care during installation, operation, adjustment and maintenance of the machine. Such risks lie entirely with the user. Depending on the specific working conditions, additional precautions may be requested.

Considering that Biffi has no direct control over particular applications, operation or maintenance conditions, it is the operator's responsibility to comply with all applicable safety rules. Please inform Biffi urgently if you face unsafe situations not described in this IOM. It is the sole responsibility of the operator to ensure that the local health and safety regulations are adhered to.

F02 are tested according to EN 21680. Noise level is less than 65 dB (grade A) at 1 m distance.

WARNING

It is assumed that the installation, configuration, commissioning, maintenance and repair works are carried out by qualified personnel and checked by responsible specialists.

WARNING

Any repair work, other than the operations outlined in this manual, is strictly reserved to qualified Biffi personnel or to personnel directly authorized by the company itself.

F02 electric actuators are designed in accordance with the applicable international rules and specifications, but the following regulations must be observed in any case:

- The general and safety regulations
- The plant specific regulations and requirements
- The proper use of personal and protective devices (glasses, clothing, gloves, etc.)
- The proper use of tools, lifting and transport equipment
- Electrical installation, use and maintenance on F02 has to be carried out in accordance with the National Legislation and statutory requirement related to the safe use of F02 actuators, applicable to the site of installation
- Should further information and guidance related to the safe use of F02 actuators is requested, please contact Biffi

WARNING

The electronic parts of the F02 and all the optional modules can be damaged by a discharge of static electricity. Before you start, touch a grounded metal surface to discharge any static electricity.

INDEX

1	General safety instructions	1
2	Machine description	4
3	Storage end pre-installation	6
4	Installation	7
5	Lubrication	15
6	Actuator setting and configuration	15
7	Maintenance and trouble-shooting	21
8	Decommissioning	22
9	Parts list and drawings	22

F02 QUARTER-TURN ELECTRIC ACTUATOR

INSTALLATION & MAINTENANCE INSTRUCTIONS

1.2 TERMS AND CONDITIONS

Biffi guarantees each single product to be free from defects and to conform to current goods specifications. The warranty period is one year from the date of installation by the first user, or eighteen months from the date of shipment to the first user, whichever occurs first.

No warranty is given for products which have been subject to improper storage, improper installation, misuse, or corrosion, or which have been modified or repaired by unauthorized personnel.

Repair work due to improper use will be charged at standard rates.

1.3 MANUFACTURER'S LIABILITY

Biffi declines all liability in the event of:

- Use of the actuator in contravention of local safety at work legislation
- Incorrect installation, disregard or incorrect application of the instructions provided on the actuator nameplate and in this manual
- Modifications without Biffi's authorisation
- Work done on the unit by unqualified or unsuitable persons

1.4 IDENTIFICATION

1.4.1 Water-, dust-proof version

F02 actuators are designed and manufactured according to EN 60529 standards.

Specific types of protection are printed on the label, as follows:

- IP66/68
- NEMA 4/4X/6 according to NEMA ICS6/ NEMA 250

1.4.1.1 Label for application in water-, dust-proof areas

Marking description (see Figure 1A).

1.4.2 Explosionproof version

The version of F02 suitable for installation in hazardous areas is designed and manufactured according to EN 50014, 50018, 50019, EN 50281-1-1 standards.

Different types of protection are available, depending on the requirements of the installation site.

The driven valve or associated gear reducer will form part of a separate risk analysis according to Directive ATEX 94/9/EC and following the EN 13463-1 and 13463-5 norms.

Specific types of protection are printed on the label, as follows:

- ATEX Ex de IIB T5 with enclosures in 'explosionproof' version and terminal board enclosure in 'increased safety' version
- FM rated as flameproof for Class I, Zone 1, Group IIB, T5; Class II, III, Div. 1, Groups E, F and G, T4
- NEMA 7 and NEMA 9

The above versions of F02 prevent the risk of explosion in the presence of gas or ignitable dusts.

F02 actuators have IP 66/68M protection degree in accordance with EN 60529.

WARNING

Whenever F02 actuators must be installed in a HAZARDOUS AREA as defined by the applicable rules, it is mandatory to check whether the actuator nameplates indicate their suitability to a hazardous area, and the appropriate protection degree. Maintenance and repair works must be carried out by qualified personnel and checked by responsible specialists.

FIGURE 1A

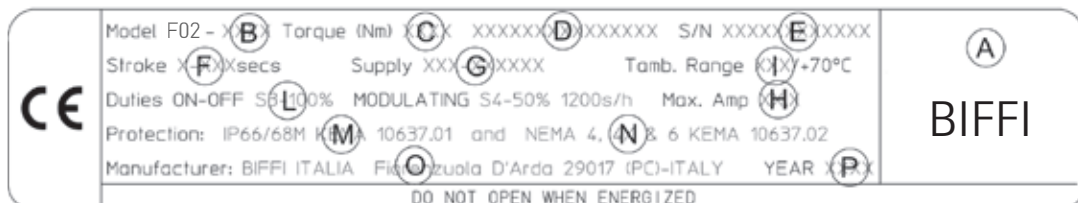

- | | |
|---------------------------------|--|
| (A) Manufacturer logo | (H) Max current absorption in ampere |
| (B) Product model | (L) Environmental data |
| (C) Nominal output torque value | (M) Weatherproof protection degree (EU & US) |
| (D) Product code | (N) Weatherproof certificate reference (EU & US) |
| (E) Serial number | (O) Manufacturer details |
| (F) Stroking time range | (P) Year of construction |
| (G) Power supply data | |

F02 QUARTER-TURN ELECTRIC ACTUATOR

INSTALLATION & MAINTENANCE INSTRUCTIONS

1.4.2.1 ATEX label for application in hazardous areas

FIGURE 1B

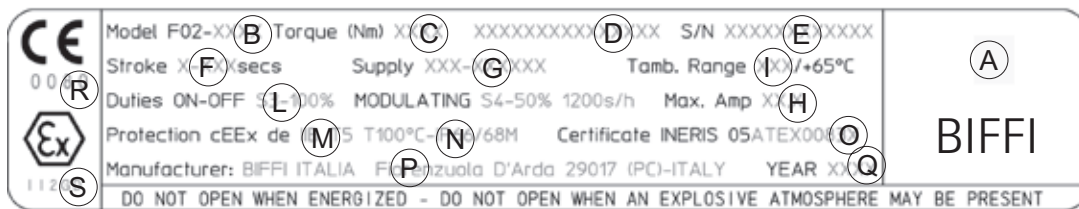

- (A) Manufacturer logo
- (B) Product model
- (C) Nominal output torque value
- (D) Product code
- (E) Serial number
- (F) Stroking time range
- (G) Power supply data
- (H) Max current absorption in ampere (at 24 V DC)
- (I) Environmental data
- (L) Actuator duties
- (M) Explosionproof protection degree
- (N) Weatherproof protection degree
(IP66/NEMA types 4,4X&6 when labelled FM)
- (O) ATEX certificate reference
- (P) Manufacturer details
- (Q) Year of construction
- (R) Notified body for ATEX quality assurance (Ineris)
- (S) ATEX marking

1.5 APPLICABLE STANDARDS AND REGULATIONS

- EN ISO 12100-1 Safety of machinery - Basic concepts, general principles for design Part 1 - Basic terminology, methodology
- EN ISO 12100-2 Safety of machinery - Basic concepts, general principles for design Part 2 - Technical principles and specification
- EN 60204-1 Electrical equipment of industrial machines Part 1 - General requirements
- 98/37/EC Machinery Directive
- 2006/95/EC Low Voltage Directive
- 2004/108/EC EMC Directive
- 94/9/EC ATEX Directive

1.6 EXTRACT FROM THE STANDARD

Type of hazard zone	Zone	Categories according to 94/9/EC Directive
Gas, mist or vapors	0	1G
Gas, mists or vapors	1	2G
Gas, mists or vapors	2	3G
Dust	20	1D
Dust	21	2D
Dust	22	3D

1.7 MANUFACTURER

Manufacturer with respect to Machinery Directive 98/37 is Biffi Italia, as specified on the actuator label.

2. MACHINE DESCRIPTION

2.1 GENERAL

The F02 is an electric quarter-turn actuator suitable to operate a valve in a 90° manoeuvre.

2.2 PRINCIPLE OF OPERATION

The electric motor drives the input to an epicyclical gear train via a spur reduction. The input member of the epicyclical gear train carries two compound planet gears which meshes with one internally toothed gears: the fixed annulus. The fixed annulus gear has external helical teeth meshing with a transversely fixed worm gear. Since the annulus cannot drive the worm gear this provides a fixing point for the annulus, and since the worm gear can drive the annulus, a means of manual operation is provided which needs no declutch.

An end-of-travel-position detection device is operated via a position sensor directly linked to the output shaft. The valve position is continuously monitored in electric mode by means of a position sensor directly connected to the F02 output drive.

2.3 ELECTRICAL OPERATION

- Control command 'open': counter-clockwise or clockwise rotation (selectable on the logic board) moves the valve to a completely or partially open position.
 - Control command 'closed': clockwise or counter-clockwise rotation (selectable on the logic board) moves the valve to a completely or partially closed position.
- Control system details are shown in the specific wiring diagram.

IMPORTANT

Handwheel rotation

In standard applications clockwise rotation of the handwheel moves the valve to close position and counter-clockwise rotation moves the valve to open position.

Different operation are clearly indicated on the handwheel.

2.4 MANUAL OPERATION

To be used in case of power supply failure or during actuator setting.

The manual operating device is completely independent of the motor drive and can be operated at any time, whether or not the motor is running, without danger to the operator. The handwheel does not rotate during power operation.

To close the valve turn the handwheel clockwise.

To open the valve, turn the handwheel counter-clockwise.

If the handwheel is turned during electric operator, an error will occur and the actuator will stop. After few seconds the actuator will restart its operation and move the valve to the requested position

FIGURE 2



F02 QUARTER-TURN ELECTRIC ACTUATOR

INSTALLATION & MAINTENANCE INSTRUCTIONS

2.5 DESCRIPTION OF THE MAIN PARTS

The F02 actuator consists of five main parts:

- Base flange: for coupling the actuator to the valve
- Terminals enclosure: for power and signal cable connection through four available cable entries
- Mechanical gearing: internal epicyclical gear reduction, which increases the torque of the electric motor
- Control unit: integral control unit inclusive of electric motor with the relevant driver, power and logic electronic card. By way of the mechanical gearing, the electric motor operates the valve in normal working conditions
- Manual override: for actuator manual operation in case of power supply failure or during actuator setting

2.6 OPTIONAL MODULES

F02 actuators can be provided with several optional modules, as listed in the table below. Please refer to this table for possible combinations of available modules.

2.7. OPTIONS LABEL

A label is always provided with base actuators where optional modules will have to be checked out once they are installed after delivery at local organisations' care.

Options Label		
S/N:		
OM1	OM3	OM9
OM11	OM13	

FIGURE 3

OPTIONAL MODULES SELECTION TABLE

Order code	OM1 I/O additional module	OM3 local interface	Bluetooth component	OM9 PDP V0/V1	OM11 DeviceNet	OM13 3 wires module
P1	✓					
PA	✓	✓	✓			
P6	✓	✓				
P7	✓		✓			
P3		✓				
5P			✓	✓		
6P		✓	✓	✓		
5D			✓		✓	
6D		✓	✓		✓	
PG						✓

NOTES

1. Each optional module (OMx) will be provided with its own Installation & Maintenance Instructions. All modules except OM13 are available for both 1-phase and 3-phase voltage versions.
2. Bluetooth component is integrated in the OM1, OM9 and OM11 card: not available for integration by local organizations, as a stand alone unit.
3. OM13 is not available with 3-phase supply. Not available for LV version (1-phase voltage from 24 to 48 V DC/V AC).

Please make sure the label is stuck where shown in the picture below.



FIGURE 4

3. STORAGE AND PRE-INSTALLATION

3.1 CHECKS TO BE CARRIED OUT WHEN THE ACTUATOR IS RECEIVED

IMPORTANT

Not performing the following procedures will invalidate the product guarantee.

First of all check if the data on the nameplate (model, serial number, nominal torque, nominal voltage range, protection degree, operating speed range, protection class, etc.) correspond to the expected product data.

If the actuator is received already assembled onto the valve, the setting of the mechanical stops and of the electric end-of-travel should have been already done during actuator assembly onto the valve. An additional check is anyway recommended to verify that all the requested settings have been completed as indicated in the present Instruction and Operating Manual.

If the actuator is received separately from the valve, the setting of the mechanical stops and of the electric end-of-travel must be checked and, if necessary, carried out while assembling the actuator onto the valve. In any case, all the setting operations described in this Instruction and Operating Manual must be carried out. Check that the actuator was not damaged during transport: in particular, inspect the local position indicator area glass. If necessary, repair all damages to the paint-coat, etc. Check that the fitted accessories comply with those listed in the order acknowledgement and the delivery note.

3.2 STORAGE PROCEDURE

3.2.1 General

The actuators leave the factory in perfect working conditions and with an excellent finish, in order to maintain these characteristics until the actuator is installed on site, it is necessary to observe a few rules and take appropriate measures during the storage period.

The basic version of F02 actuators is weatherproof to IP66/68. This condition can only be maintained if the units are correctly installed and connected on site, and if they were previously correctly stored. The standard plastic plugs used to close the cable entries are not weatherproof, they just prevent the entry of undesired objects during transport. Biffi cannot accept responsibility for deterioration caused on site when the covers are removed.

IMPORTANT

The actuator handwheel is removed for transport. If the actuator must be shipped fully assembled, please make sure the handwheel is packed securely to avoid all possible damage.

3.2.2 Storage for a brief period (less than one year)

3.2.2.1 Indoor storage

- Make sure the actuators are kept in a dry place, laid on a wooden pallet (not directly on the floor surface) and protected from dust
- In very humid environments, a moisture absorbent desiccant packet should be introduced in the motor enclosure. (Desiccant is not included in the actuator package)

3.2.2.2 Outdoor storage

- Make sure the actuators are protected from the direct action of weather agents (protection by a canvas tarp or similar). Environment temperature: -20°C to +65°C
- Place the actuators on a wooden pallet, or some raised platform, so that they are not in direct contact with the ground, and protected from dust
- In very humid environments, a moisture absorbent desiccant packet should be introduced in the motor enclosure. (Desiccant is not included in the actuator package)
- If the actuators are supplied with standard plastic plugs, remove them from the cable entries and replace them with weatherproof plugs

3.2.3 Long period storage (more than one year)

3.2.3.1 Indoor storage

In addition to the instructions at point 3.2.2.1:

- If the actuators are supplied with standard plastic plugs, replace them with weatherproof plugs
- The coupling parts (i.e. flange, etc.) must be coated with a protective oil or grease; (if possible, blank off the flange by a protection disk)

3.2.3.2 Outdoor storage

In addition to point 3.2.2.2:

- If the actuators are supplied with standard plastic plugs, replace them with weatherproof (metal) plugs
- The coupling parts (i.e. flange, etc.) must be coated with a protective oil or grease; (if possible, blank off the flange by a protection disk)
- Check the actuator general conditions, paying particular attention to the terminal board

4. INSTALLATION

4.1 CHECKS TO BE PERFORMED BEFORE INSTALLATION

To assemble the actuator onto the valve proceed as follows:

- Check that the coupling dimensions of the valve flange and stem, or of the relevant extension, meet the actuator coupling dimensions
- The electrical supply cables must be suitable for the power rating
- Gather the necessary tools for the assembly and configuration of the actuator controls
- Lubricate the valve stem with oil or grease to make the assembly easier: pay attention not to contaminate with lubricant the flange surfaces which transmit the actuator torque
- Clean the valve flange and remove anything that might prevent a perfect adherence to the actuator flange and especially all traces of grease
- Install the actuator onto the valve so that the shaft output drive enters the groove of the stem extension. This coupling must take place without forcing and only with the weight of the actuator. When the actuator output shaft and the valve stem are connected, check the holes of the valve flange. If they do not meet with the holes of the spool piece flange or the stud bolts screwed into them, the actuator shaft output drive must be rotated. Actuate the manual override until coupling is made possible. Tighten the nuts of the connecting stud bolts evenly
- If possible, operate the actuator to verify it moves the valve smoothly

If a long storage period has occurred, before reinstalling the actuator, please:

- Check the status of the O-ring seals
- Check the installation of the plugs or cable glands on the cable entries
- Check whether the enclosure covers or the actuator body are cracked or broken

4.2 WORKING CONDITION

Standard F02 actuators are suitable for the following environment temperatures:

- -25°C to +70°C (-13°F to +158°F)

Special versions are available for extreme environment temperatures:

- -40°C to +70°C (-40°F to +158°F)

4.3 COUPLING BLOCK

The electric actuator is delivered with drive details and flange in accordance with the technical characteristics required by the customer, ready to be installed onto the valve. Only one insert is included in the actuator package delivered to end users.

IMPORTANT

Check the 'ambient temperature range' printed on the nameplate, for the correct utilisation with respect to the ambient temperature. Installation in ambient with temperature range outside the specified values will invalidate the warranty.

WARNING

During normal operation the temperature of the actuator surface can reach 30°C above the ambient temperature.

IMPORTANT

In case the screws of the cover, of the terminal compartment and of the OM3 must be replaced, SS Class A4 grade 80 screw must be used with minimum yield strength 600 N/mm². Every time the main cover, the terminal compartment cover and the OM3 are reassembled, make sure to tight all the screws with 5 Nm torque.



FIGURE 5 - Overview of one type of insert and drive details of the F02.

F02 QUARTER-TURN ELECTRIC ACTUATOR

INSTALLATION & MAINTENANCE INSTRUCTIONS

WARNING

Never lift the valve/actuator assembly without securing slings to both the valve and the actuator.

Never use the handwheel to lift the actuator.

4.4 INSTALLATION OF THE F02 UNIT ONTO A VALVE

Move the valve to the completely open position. Manually bring the F02 to the completely open position (verify the local mechanical indicator) and check the rotation direction of actuator and valve. The actuator should be mounted for counter-clockwise rotation to open and clockwise to close.

The F02 unit can be installed onto the valve in two different ways:

Direct mounting:

Insert the valve shaft into the actuator bottom flange, taking care to correctly connect the insert. Fix the screws on the valve flange to the actuator coupling block.

Bracket mounting:

Install the bracket and the adapter onto the valve; then insert the valve shaft into the actuator bottom flange, taking care to correctly connect the insert.

Fix the screws between the bracket and the valve flange and the actuator coupling block.

4.5 MANUAL OPERATION

F02 electric actuators are supplied with a handwheel for manual override as standard, to operate the actuator in case of power supply failure or during setting.

The handwheel is always engaged. For safe operation, the handwheel does not rotate during electric operation.

Turn the handwheel clockwise to close and counter-clockwise to open.

During manual operation, check the actuator manoeuvre on the local mechanical indicator.

WARNING

Do not manually operate the actuator with devices other than the handwheel. Using cheater bars, wheel wrenches, pipe wrenches, or other such devices on the actuator handwheel may cause serious personal injury and/or damage to the actuator or valve.



FIGURE 6 - Manual operation.

F02 QUARTER-TURN ELECTRIC ACTUATOR

INSTALLATION & MAINTENANCE INSTRUCTIONS

4.6 SETTING OF THE ANGULAR STROKE: MECHANICAL STOPS

It is important for the mechanical stops to end the angular stroke at both extreme valve positions (fully open and fully closed). The setting of the angular stroke is performed by adjusting the travel stop screw mounted on the actuator housing.

For the adjustment of the stop screw proceed as follows:

- Loosen the lock nut
- Screw 1: open
To set the mechanical stop in opening, manually bring the actuator to the completely open position, then turn screw 1 clockwise to find the correct position, then block it by means of the nut

- Screw 2: close
To set the mechanical stop in closing, manually bring the actuator to the completely close position, then tighten screw 2

If the actuator angular stroke is stopped before reaching the end position (fully open or closed), proceed as follows:

- Unscrew the stop screw by turning it anticlockwise until the valve reaches the correct position
- When unscrewing the stop screw, keep the lock nut still with a wrench so that the sealing washer does not withdraw together with the screw
- Tighten the lock nut

If the actuator angular stroke is stopped beyond the end position (fully open or closed), proceed as follows:

- Screw the stop screw by turning it clockwise until the valve reaches the correct position
- Tighten the lock nut

4.7 ELECTRICAL CONNECTIONS

Before powering the actuator, check that the supply voltage details on the nameplate are correct for the plant. Access to terminals for electrical connections is through the terminal cover.

WARNING

After electrical on-field installation, please make sure all removal of the cover assembly is done in total observance of the applicable safety rules.

All the accessories (cable glands in particular) must be certified according to the requirements of the installation area and the relevant applicable regulations.

Setting must be done while the actuator is powered on. As a consequence, all setting operations must be carried out by specifically qualified personnel for operations on powered electronic cards.

4.8 PLANT REQUIREMENTS

Protection devices (over-current breakers, magneto-thermal switches or fuses) must be provided by the customer to protect the main lines in case of motor over-current or loss of insulation between phases and earth.

IMPORTANT

The following circuit breakers were identified on the basis of the actuator technical features:

- Reference: IEC EN 60947-2
- Characteristic: K

It is the plant engineer's or installer's responsibility to select the most appropriate electric protection.



FIGURE 7 - Setting of the mechanical stop.

F02 QUARTER-TURN ELECTRIC ACTUATOR

INSTALLATION & MAINTENANCE INSTRUCTIONS

FIGURE 8 - CURRENT ABSORPTION 1-PHASE POWER SUPPLY HIGH VOLTAGE (100-240 V DC / V AC)

SIZE 63 Nm - ABSORPTION (mA)

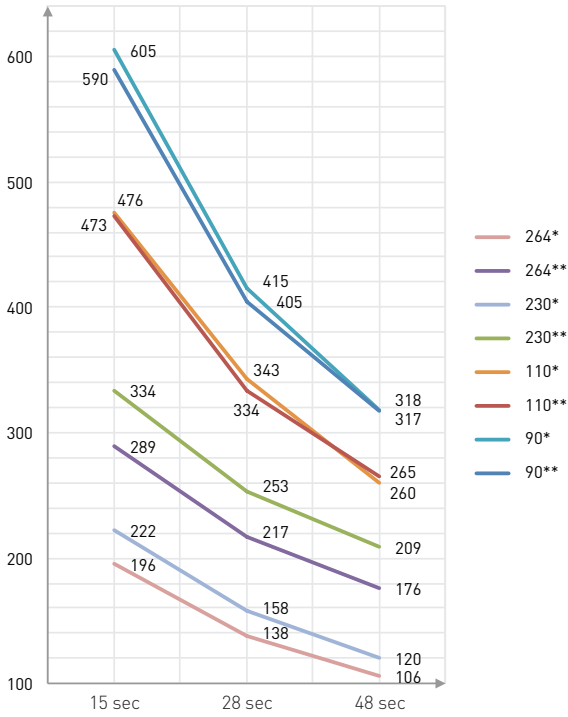

SIZE 125 Nm - ABSORPTION (mA)

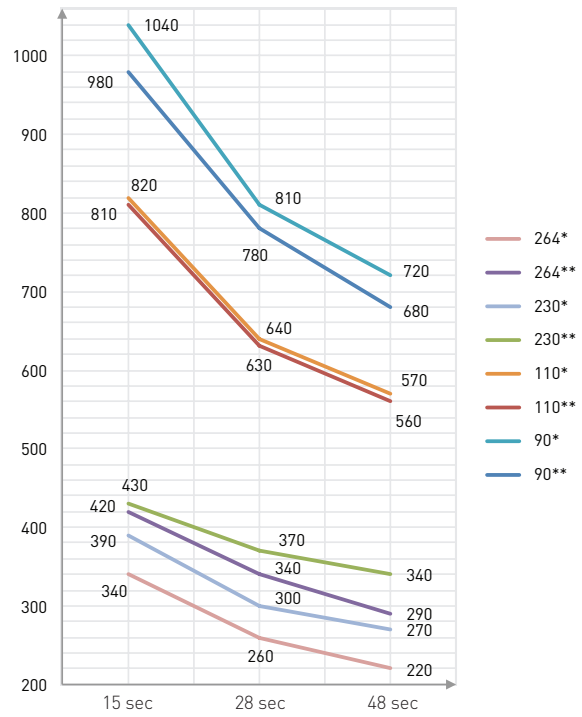

SIZE 250 Nm - ABSORPTION (A)

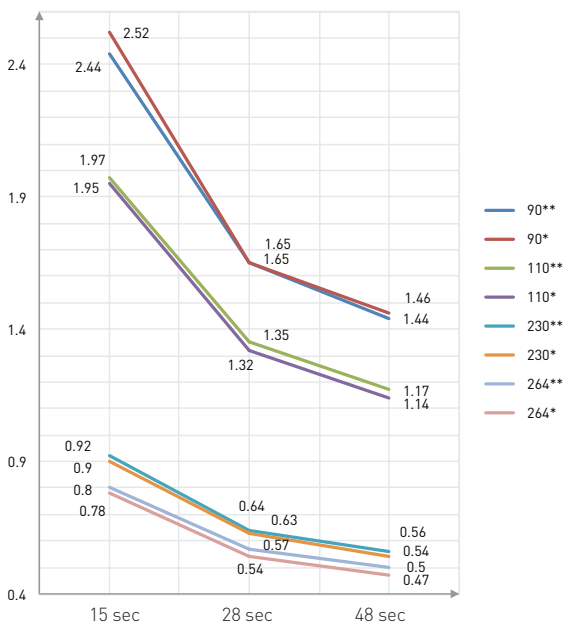

SIZE 500/1000/2000 Nm - ABSORPTION (A)

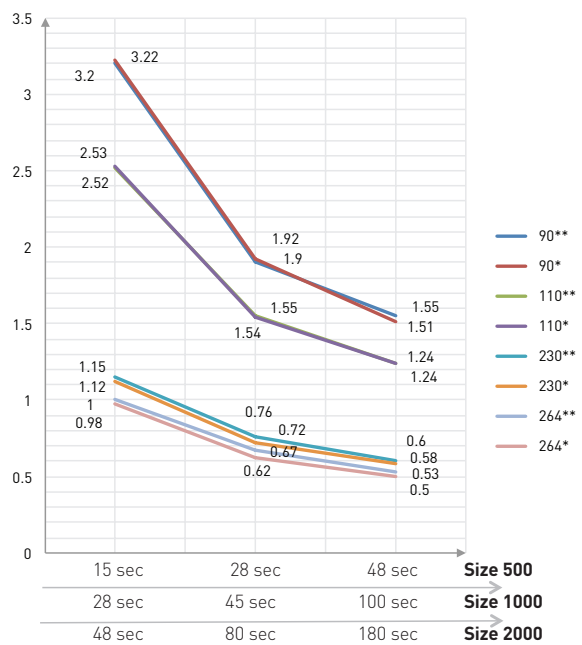

NOTES

* V DC ** V AC

- 1) A = absorbed current (Amp) at nominal conditions (output torque 100%)
- 2) Max current (Amp) at stall conditions = 2xA
- 3) Power factor for V AC supply = 0.60
- 4) Peak current: max 8xIn
- 5) Peak current duration: less than 0.1 secs

F02 QUARTER-TURN ELECTRIC ACTUATOR

INSTALLATION & MAINTENANCE INSTRUCTIONS

FIGURE 9 - CURRENT ABSORPTION (THREE PHASE VOLTAGE)

SIZE 63 Nm - ABSORPTION (mA)

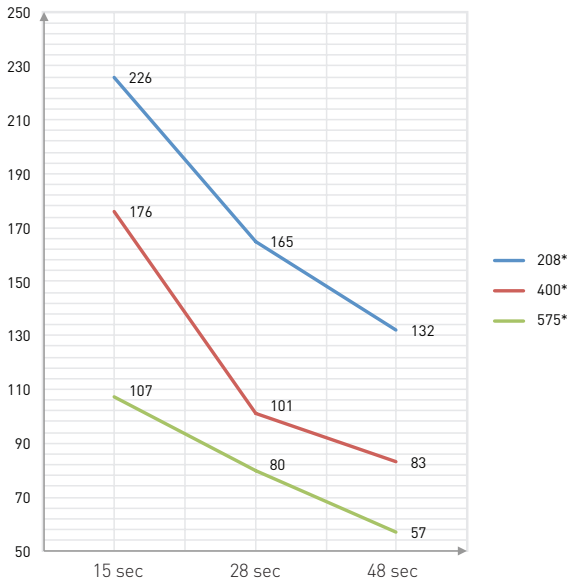

SIZE 125 Nm - ABSORPTION (mA)

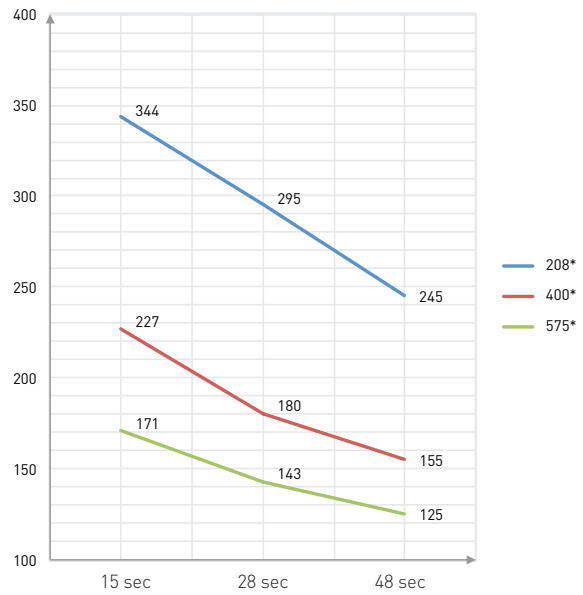

SIZE 250 Nm - ABSORPTION (mA)

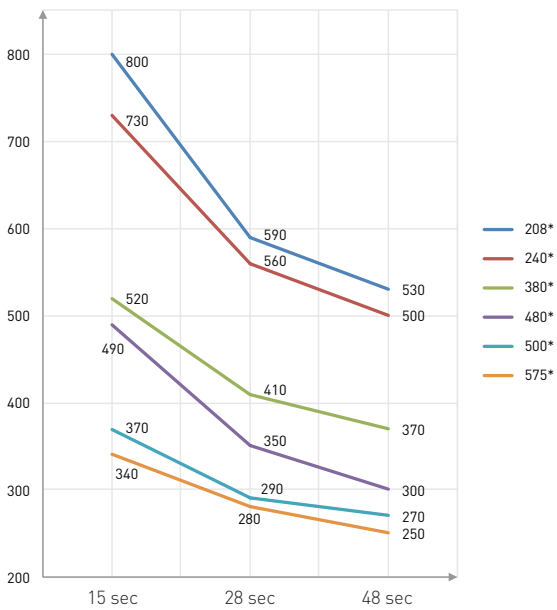

SIZE 500/1000/2000 Nm - ABSORPTION (mA)

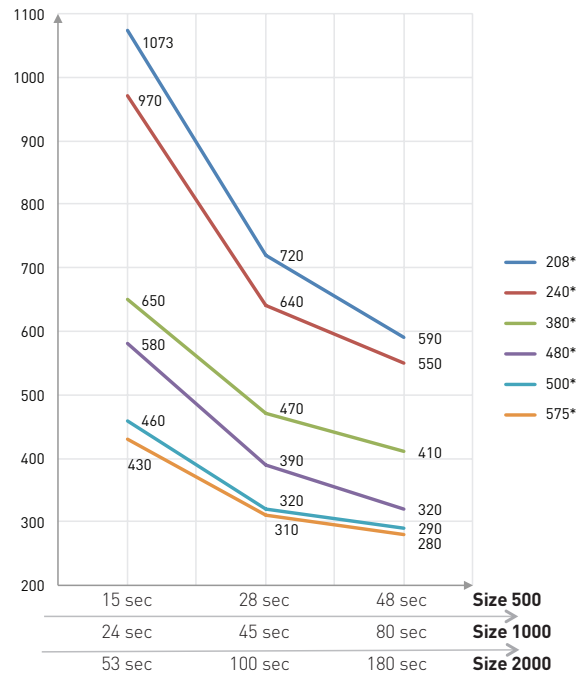

NOTES

- * V AC
- 1) 3-phases supply 50 or 60 Hz
- 2) A = absorted current (Amp) at nominal conditions with output torque set at 100%
- 3) Power factor = 1 approx.
- 4) Starting current peak less than 10 microseconds

4.9 REMOVAL OF THE TERMINAL BOARD ENCLOSURE

Using a 5 mm Allen key, loosen the four screws and remove the cover.



FIGURE 10 - Removal of the terminal board enclosure.

WARNING

Pay attention not to damage the joint surfaces of the cover.

4.10 CABLES CONNECTIONS

Before applying voltage to the F02 check that the electrical parameters (supply voltage and current) shown on the nameplate and on the attached wiring diagram are correct for the installation.

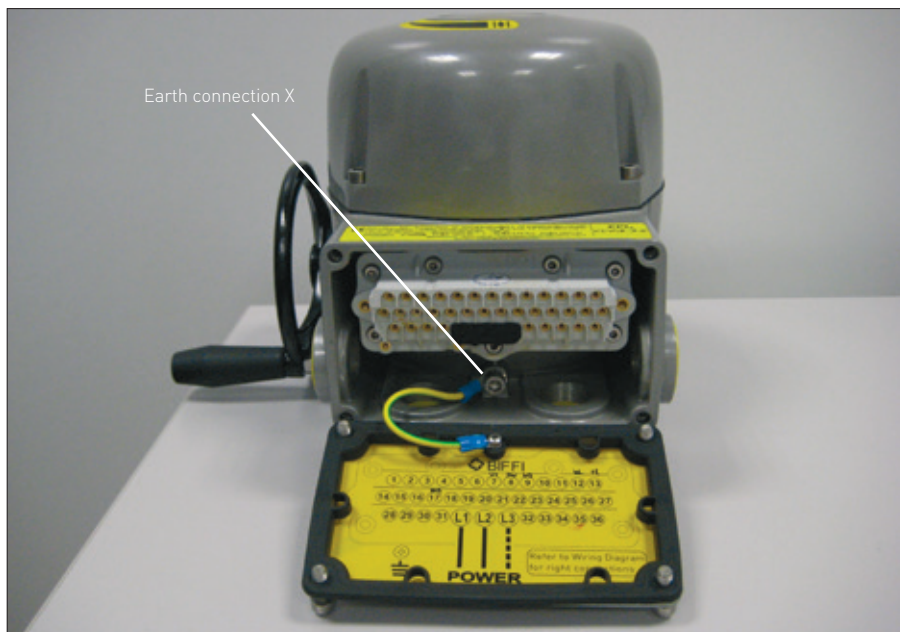

FIGURE 11 - Overview of the electrical connections.

IMPORTANT

All the accessories which equip the F02, in particular the cable glands, must be certified according to the Standard Directive and specific Rules applying to the products.

WARNING

Do not remove earth connection X while connecting the actuator to plant earthing.

F02 QUARTER-TURN ELECTRIC ACTUATOR

INSTALLATION & MAINTENANCE INSTRUCTIONS

Remove the plugs from the cable entries. For electrical connections use components (cable glands, cables, hoses, conduits) which meet the requirements and the applicable codes of the plant specifications (mechanical protection and/or explosionproof protection). Screw the cable glands (or the conduits) tightly into the threaded entries, in order to guarantee the weatherproof and explosionproof protection (when applicable). Insert the connection cables into the electrical enclosures through the cable glands (or conduits) and, according to the wiring diagram in the main terminal board enclosure, connect the electrical supply, the control and the signal

cables to the actuator, by linking them to the terminal blocks termination as per diagram. Replace the plastic plugs of the unused cable entries by metal ones, to guarantee perfect weatherproof tightness and to comply with the explosionproof protection codes (where applicable). Once the connections are completed, check that the controls and signals work properly. Two ground studs, one internal and one external, are provided to meet all local electric and safety regulations. Terminate the ground connections at least to the external stud marked GROUND.

Connect the motor supply cable previously sized in accordance with:

- The absorbed current correspondent to the actuator nominal torque with the torque limiting device set at 100 percent
- Cable size; 1 power: 4 mm²/AWG12 (max)
2 controls: 1,5 mm²/AWG 16 (max)
- The applicable plant and safety norms

4.11 BASE WIRING DIAGRAM (FIGURE 12)

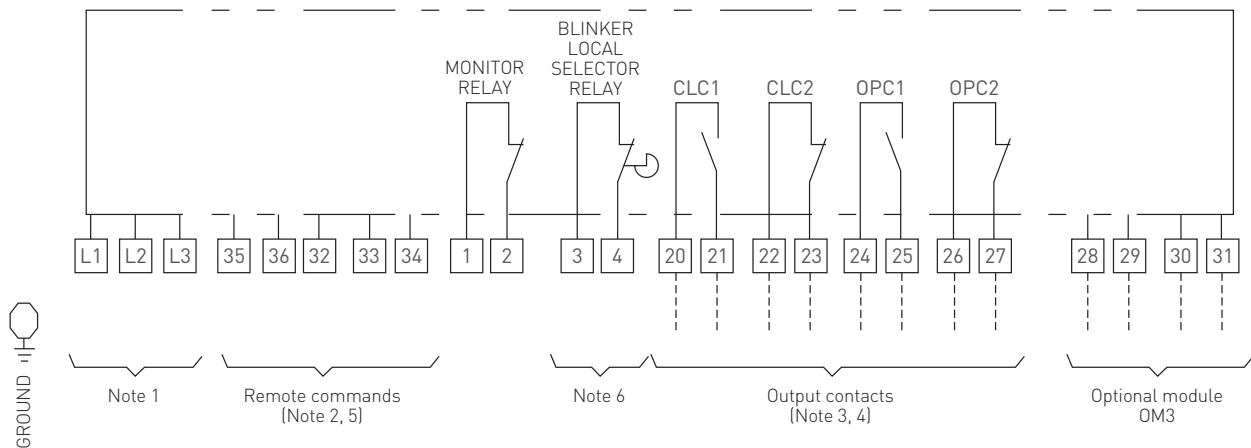

NOTES

1. Power connection L1-L2 for V DC or V AC single phase motor supply from 24 V to 48 V or from 100 V to 240 V. Power connection L1-L2-L3 for 3-phase motor supply from 208 V to 575 V (check the actuator label for the correct voltage to be applied).
2. Remote command options.

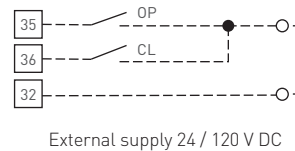
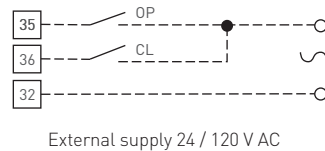
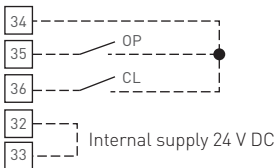

3. Contacts shown in intermediate position CLC1-CLC2 end of travel signaling in closing. Contacts shown in intermediate position OPC1-OPC2 end of travel signaling in opening.
4. Output contact rating 240 V AC / 5 A ; 30 V DC / 5A ; 120 V DC / 0.5 A.
5. Control command rating 24 to 120 V AC or DC.
6. Blinker or Local Selector monitoring function (when OM3 is present) to be configured.

WARNING

It is under user responsibility to limit the rated impulse voltage level at 1500 V.

F02 QUARTER-TURN ELECTRIC ACTUATOR

INSTALLATION & MAINTENANCE INSTRUCTIONS

4.12 CABLE ENTRIES

The sealing of cables and conduit entries should be carried out in accordance with National Standards or the Regulatory Authorities that have certified the actuators. This is particularly true for units that are certified for use in hazardous areas where the method of sealing must be to an approved standard, and cable glands, reducers, plugs and adapters must be approved and separately certified.

IMPORTANT

- To prevent any water infiltration through the cable conduits, make sure the cable glands have the minimum protection degree required by the plant.
- If rigid conduits are used, we suggest placing a flexible pipe connection between the conduit and the terminal board.

In order to properly connect the cables, remove the cable entry plugs and make all the necessary connections.

To guarantee the proper weatherproof fit, degree IP66/68 must be ensured: screw the cable glands tightly and block them with a thread sealant. The use of a thread sealant is necessary in case of explosionproof application.

If some parts of the cable glands have been removed while working on the cable entries, put them back into place in order to avoid losing the dismantled parts.

Unused entries:

- For explosionproof construction: unused entries must be plugged with metal explosionproof plugs and blocked with a thread sealant
- For weatherproof construction: replace the standard plastic protection plugs supplied with the actuator with suitable plugs to guarantee the requested protection degree

IMPORTANT

In order to physically separate the power from the signal terminal, place the power clamps protection (provided with the actuator) on the power terminal, once you have completed the power cable connection. This will avoid any accidental contact with the power terminals during the cabling operation on the signal terminals.



FIGURE 13 - Overview of the cable entries conduits.

4.13 SAFETY INSTRUCTIONS FOR INSTALLATION IN HAZARDOUS AREA

4.13.1 Instructions for explosionproof enclosures

IMPORTANT

F02 electric actuators must be installed and maintained according to the applicable Rules regarding the electrical installation in hazardous areas (other than mines) classified as zone 1 and/or 2 (gas) and zone 21 and/or 22 (dust) according to EN 60079-10 (hazardous area classification). Example: EN 60079-14 (electrical installation), EN 60079-17 (maintenance).

During the dismantling and subsequent reassembling of the explosionproof enclosures (covers, cable glands, joints) be careful to bring these enclosures back to their original condition to maintain their integrity. In particular, be sure the joint surfaces of all enclosures are spread with a film of recommended grease.

Proceed as follows:

- Do not damage the explosionproof mating surfaces on the housing and on the electrical enclosure covers
- Reinstall all the screws that go with the dismantled parts, and block them with a thread sealant after spreading them with a film of copper- or molybdenum-based grease. This will keep screws from sticking and make maintenance operations easier

- Check that the bolts and screws are the same dimension and quality as the original ones (as stated on the nameplate), or a better quality
- Replace the weatherproof seals that may have been removed (O-ring for the covers)

IMPORTANT

In case the screws of the cover must be replaced, SS Class A4 grade 80 screw must be used with minimum yield strength 600 N/mm²

WARNING

Do not electrically operate the F02 when the electrical enclosures are removed. Do not open the actuator covers when an explosive atmosphere may be present. Ignoring the above precautions could cause personal injury.

IMPORTANT

Each time the covers are opened or removed the condition of the seals must be checked. In case the seals are replaced, original spares must be supplied by Biffi.

IMPORTANT

*F02 electric actuators must be installed and maintained according to the applicable rules regarding the electrical installation in hazardous areas (other than mines) classified as zone 21 and/or 22 (dust) according to EN 60079-10 (hazardous area classification).
Example: installation and maintenance according to EN 50281-1-2.*

Special attention is requested to the following:

- Before the assembly the joint surfaces must be greased with silicone oil or equivalent
- Cable glands must have minimum protection degree IP66/68 (EN 60529)
- Periodically verify the quantity of dust deposited on the enclosure and clean it if more than 5 mm using a damp cloth to avoid static electricity

5. LUBRICATION

5.1 LUBRICATION INSPECTION

The actuator is grease lubricated for life, therefore under normal working conditions no grease needs to be replaced or added.

In case of maintenance the following grease is recommended:

- AEROSHELL GREASE 7 or equivalent, for ambient temperature -40°C to +70°C.

6. ACTUATOR CONFIGURATION

Before connecting power to the actuator, check that the voltages are correct and according to the indications on the nameplate. Wrong power supply could cause permanent damage to the electrical components.

The configuration of the F02 actuator can be carried out through the control panel inside the actuator control system. To access the panel, remove the actuator cover and when the configuration is complete replace the cover, following the procedures indicated below.

IMPORTANT

When optional local control panel OM3 is installed and the actuator setting is done by means of the pushbuttons on the logic board, the remote controls do not have to be energized.

6.1 REMOVAL OF THE CONTROL UNIT COVER

Using a 5 mm Allen key, loosen the four screws and remove the cover.

IMPORTANT

When setting the actuator parameters do not operate the actuator neither remotely nor locally.

WARNING

Pay attention not to damage the joint surfaces of the cover.

IMPORTANT

In case the screws of the cover must be replaced, SS Class A4 grade 80 screw must be used with minimum yield strength 600 N/mm²

Once the configuration is completed, reassemble the actuator cover.

F02 QUARTER-TURN ELECTRIC ACTUATOR

INSTALLATION & MAINTENANCE INSTRUCTIONS



FIGURE 14 - Removal of the control unit cover.

6.2 LOCAL CONFIGURATION OF THE F02

WARNING

The configuration must be done while the actuator is powered on. As a consequence, all configuration operations must be carried out by specifically qualified personnel for operations on powered electronic cards.

6.2.1 F02 default general configuration

IMPORTANT

The actuators are set in the workshop with the following configuration (default value):

- CL limit switch by position
- OP limit switch by position
- Stroking time in CL (δ): 28 secs for models 063/125/250/500, 45 secs for model 1.000 and 100 secs for model 2.000
- Stroking time in OP (δ): 28 secs for models 063/125/250/500, 45 secs for model 1.000 and 100 secs for model 2.000
- Torque limiting device in CL set at about 100% of nominal torque
- Torque limiting device in OP set at about 100% of nominal torque
- Reverse mode off
- Monitor Relay NC (in normal condition, i.e. without alarms)
- Blinker / Local Selector relay off (always Open)

If the application requires different actuator configurations, please proceed as described in this chapter.

IMPORTANT

Please note that the actuator configuration does not need to be done in succession as indicated in the following pages. Each parameter can be set independently.

The configuration of the actuator parameters is done through the following tools:

- Two rotary selector switches SW6 and SW4 for actuator configuration
- Enter pushbutton SW5 (confirmation pushbutton)
- Dip switch SW3 (enable configuration function)
- Green LED indicating power ON (switched on when power supply is available)
- Red LED for Enter confirmation (ON once configuration is confirmed)
- Mechanical stops

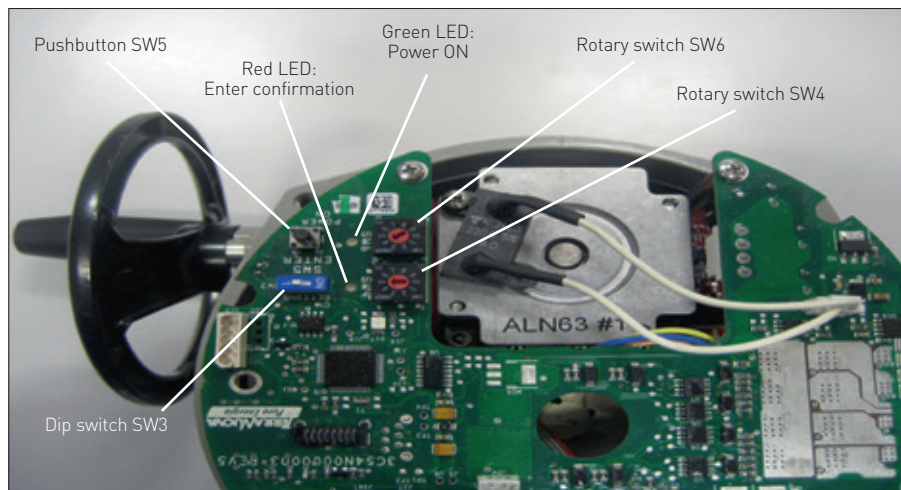

FIGURE 15 - Configuration of the actuator parameters.

F02 QUARTER-TURN ELECTRIC ACTUATOR

INSTALLATION & MAINTENANCE INSTRUCTIONS

SETUP BASE CARD

Setup	Rotary switches position		Dip switch	Enter button	Default
	SW4	SW6	SW3	SW5	
Close limit	0	0	ON	PUSH	n.d.
Open limit	1	0	ON	PUSH	n.d.
L/S close	2	1: by position	ON	PUSH	1
	2	0: by torque	ON	PUSH	
L/S open	3	1: by position	ON	PUSH	1
	3	0: by torque	ON	PUSH	
Closing speed	4	4	ON	PUSH	6
	4	6	ON	PUSH	
	4	8	ON	PUSH	
Opening speed	5	4	ON	PUSH	6
	5	6	ON	PUSH	
	5	8	ON	PUSH	
% Closing torque	6	2: 50%	ON	PUSH	9
	6	5: 75%	ON	PUSH	
	6	9: 100%	ON	PUSH	
% Opening torque	7	2: 50%	ON	PUSH	9
	7	5: 75%	ON	PUSH	
	7	9: 100%	ON	PUSH	
CW/CCW	8	0: CW;	ON	PUSH	0
	8	1: CCW;	ON	PUSH	
Size	9	0: 63 Nm / 250 Nm	ON	PUSH	0
	9	1: 125 Nm / 500 Nm	ON	PUSH	
	9	3: 1000 Nm	ON	PUSH	
	9	4: 2000 Nm	ON	PUSH	
Nm / Lbs-in	0	8: Nm	ON	PUSH	8
	0	9: Lbs-in	ON	PUSH	
Blinker / Local Selector	4	0: Off	ON	PUSH	0
	4	1: Blinker	ON	PUSH	
	4	2: Local Selector	ON	PUSH	
Heater	8	9: Active	ON	PUSH	9
	8	8: Not active	ON	PUSH	
Inversion colours LED of local control	9	2	ON	PUSH	LED Open: Green LED Close: Red

6.2.2 Close limit configuration by position

Enter set up configuration:

- Move switch SW4 to position 2
- Move switch SW6 to position 1
- Move switch SW3 to position ON
- Confirm by pushing ENTER pushbutton SW5
- When pushing SW5, the red LED switches on for confirmation
- Exit set up configuration, moving switch SW3 to position 1 or proceed with the next parameter

6.2.3 Close limit configuration

- Drive the actuator to the closed position using the handwheel
- Move switch SW4 to position 0
- Move switch SW6 to position 0
- Move switch SW3 to position ON
- Confirm by pushing ENTER pushbutton SW5
- When pushing SW5, the red LED switches on for confirmation
- Exit set up configuration, moving switch SW3 to position 1 or proceed with the next parameter

6.2.4 Open limit configuration by position

- Move switch SW4 to position 3
- Move switch SW6 to position 1
- Move switch SW3 in ON
- Confirm by pushing ENTER pushbutton SW5
- When pushing SW5, the red LED switches on for confirmation
- Exit set up configuration, moving switch SW3 to position 1 or proceed with the next parameter

6.2.5 Open limit configuration

- Drive the actuator to open position using the handwheel.
- Move switch SW 4 to position 1
- Move switch SW 6 to position 0
- Move switch SW 3 to position ON
- Confirm by pushing ENTER pushbutton SW5
- When pushing SW5, the red LED switches ON for confirmation
- Exit set up configuration, moving switch SW3 to position 1 or proceed with the next parameter

6.2.6 Close limit configuration by torque

- Move switch SW4 to position 2
- Move switch SW6 to position 0
- Move switch SW3 to position ON
- Confirm by pushing ENTER pushbutton SW5 (red LED switch on)
- Operate the actuator to closing direction by local/remote control and wait until it stops by torque
- When the setting is completed, the red LED switches off
- Exit set up configuration, moving switch SW3 to position 1 or proceed with the next parameter

6.2.7 Open limit configuration by torque

- Move switch SW4 to position 3
- Move switch SW6 to position 0
- Move switch SW3 to position ON
- Confirm by pushing ENTER pushbutton SW5 (red LED switch on)
- Operate the actuator to opening direction by local/remote control and wait until it stops by torque
- When the setting is completed, the red LED switches off
- Exit set up configuration, moving switch SW3 to position 1 or proceed with the next parameter

IMPORTANT

During the new stroke limit setup, the minimum range between open and close limit position has to be at least 40 degree of the valve position; if the above condition is not respected, the setup will not be successful and stroke limit error alarm will be signaled (red LED blinking).

The red LED will continuously flash when the actuator is in setup functionality (dip switch SW3 in 'on' position) and rotary switches SW4 and SW6 are in one of the following positions:

- SW4=3 and SW6=0
(stroke limit of open configuration by torque)*
- SW4=2 and SW6=0
(stroke limit of close configuration by torque)*
- SW4=1 and SW6=0
(stroke limit of open configuration by position)*
- SW4=0 and SW6=0
(stroke limit of close configuration by position)*

The alarm is then reset by:

- Switching off and on the actuator*
- Doing a new correct stroke limit setup in one of the 4 possible combinations.*

WARNING

In configuration phase, touch only the configuration area of the logic board; don't touch the actuator in its other parts.

6.2.8 Stroking time selection in closing

- Enter set up configuration: move switch SW3 to position ON [configuration function]
- Move switch SW4 to position 4
- Move switch SW6 to positions 4,6,8 for the requested stroking time according to the table below

- Push ENTER pushbutton SW5 to confirm
- When pushing SW5, the red LED switches on for confirmation
- The selected stroking time in closing is now set
- Exit set up configuration (move switch SW3 to position 1) or proceed with the next parameter

6.2.9 Stroking time selection in opening

- Enter set up configuration: move switch SW3 to position ON (configuration function)
- Move switch SW4 to position 5
- Move switch SW6 to positions 4,6,8 for the requested stroking time according to the table below
- Push ENTER pushbutton SW5 to confirm
- When pushing SW5, the red LED switches on for confirmation
- The selected stroking time in opening is now set
- Exit configuration (move switch SW3 to position 1) or proceed with the next parameter

OPERATING TIME SELECTION TABLE

Model	Nominal torque (Nm)	Operating time (secs 90°) at selected step		
		8	6	4
063	63	15	28	48
125	125	15	28	48
250	250	15	28	48
500	500	15	28	48
1000	1000	24	45	80
2000	2000	53	100	180

NOTE: Time is guaranteed with +/- 10% tolerance on 90° stroke

6.2.10 Setting of the torque limiting device in closing

Closing torque limits: 50%, 75% and 100% of the nominal torque. The nominal torque corresponding to 100% is set in-house and stated in the name plate.

- Enter set up configuration: move switch SW3 to position ON (configuration function)
- Move switch SW4 to position 6
- Move switch SW6 to positions 2,5 or 9 for the requested torque value (in percentage) in closing
- Push ENTER pushbutton SW5 to confirm
- When pushing SW5, the red LED switches on for confirmation
- The setting of the torque limiting device in closing manoeuvre is now complete
- Exit set up configuration (move switch SW3 to position 1) or proceed with the next parameter

WARNING

Torque switches setting must be done only with the authorization of the valve manufacturer, considering the specific valve figures.

6.2.11 Configuration of the torque limiting device in opening

Opening torque limits: 50%, 75% and 100% of the nominal torque. The nominal torque corresponding to 100% is set in-house and stated in the name plate.

- Enter set up configuration: move switch SW3 to position ON (configuration function)
- Move SW4 switch to position 7
- Move switch SW6 to positions 0-9 for the requested Torque value (in percentage) in opening
- Push ENTER pushbutton SW5 to confirm
- When pushing SW5, the red LED switches on for confirmation
- The setting of the torque limiting device in opening is now complete
- Exit set up configuration (move switch SW3 to position 1) or proceed with the next parameter

WARNING

Torque switches setting must be done only with the authorization of the valve manufacturer, considering the specific valve figures.

6.2.12 Reverse mode configuration

- Enter set up configuration: move switch SW3 to position ON (configuration function)
- Move switch SW4 to position 8
- Move switch SW6 to position:
1 counter-clockwise (CCW) ON
0 counter-clockwise (CCW) OFF
- Push ENTER pushbutton SW5 to confirm
- When pushing SW5, the red LED switches on for confirmation
- Reverse mode (CCW) set is now completed
- Exit set up configuration (move switch SW3 to position 1) or proceed with the next parameter

6.2.13 Actuator model selection

The frames relevant to models 63/125 and 250/500 can be set to operate with a 63 Nm or 125 Nm motor and a 250 Nm or 500 Nm motor respectively.

The difference is based on the technical characteristics of the electric motor itself.

Actuator model 63

- Enter set up configuration: move switch SW3 to position ON (configuration function)
- Move switch SW4 to position 9
- Move switch SW6 to position 0
- Confirm by pushing ENTER pushbutton, SW5
- When pushing SW5, the red LED switches on for confirmation
- Exit set up configuration (move switch SW3 to position 1) or proceed with the next parameter

Actuator model 125

- Enter set up configuration: move switch SW3 to position ON (configuration function)
- Move switch SW4 to position 9
- Move switch SW6 to position 1
- Confirm by pushing ENTER pushbutton SW5
- When pushing SW5, the red LED switches on for confirmation
- Exit set up configuration (move switch SW3 to position 1) or proceed with the next parameter

Actuator model 250

- Enter set up configuration: move switch SW3 to position ON (configuration function)
- Move switch SW4 to position 9
- Move switch SW6 to position 0
- Confirm by pushing ENTER pushbutton SW5
- When pushing SW5, the red LED switches on for confirmation
- Exit set up configuration (move switch SW3 to position 1) or proceed with the next parameter

Actuator model 500

- Enter set up configuration: move switch SW3 to position ON (configuration function)
- Move switch SW4 to position 9
- Move switch SW6 to position 1
- Confirm by pushing ENTER pushbutton SW5
- When pushing SW5, the red LED switches on for confirmation
- Exit set up configuration (move switch SW3 to position 1) or proceed with the next parameter

Actuator model 1.000

- Enter set up configuration: move switch SW3 to position ON (configuration function)
- Move switch SW4 to position 9
- Move switch SW6 to position 3
- Confirm by pushing ENTER pushbutton SW5
- When pushing SW5, the red LED switches on for confirmation
- Exit set up configuration (move switch SW3 to position 1) or proceed with the next parameter

Actuator model 2.000

- Enter set up configuration: move switch SW3 to position ON (configuration function)
- Move switch SW4 to position 9
- Move switch SW6 to position 4
- Confirm by pushing ENTER pushbutton SW5
- When pushing SW5, the red LED switches on for confirmation
- Exit set up configuration (move switch SW3 to position 1) or proceed with the next parameter

6.2.14 Blinker / Local Selector configuration

Default configuration for Blinker / Local Selector relay is off (always Open)

In Blinker configuration, during actuator movement the relay changes their status each 500 msec (Motor Running function).

In Local Selector configuration (with Local Interface OM3 installed), the relay is CLOSE when OM3 switch is on REMOTE, while it is OPEN when OM3 switch is on LOCAL.

To configure Blinker or Local Selector monitoring function (when OM3 is present):

- Enter set up configuration: move switch SW3 to position ON (configuration function)
- Move switch SW4 to position 4
- Move switch SW6 to position 1 (Blinker) or 2 (Local Selector)
- Confirm by pushing ENTER pushbutton SW5
- When pushing SW5, the red LED switches on for confirmation
- Exit set up configuration (move switch SW3 to position 1) or proceed with the next parameter

6.3 CONFIGURATION OF THE F02 BY A PDA / PC AND 'A MANAGER' SOFTWARE

If one of the optional module OM1, OM9 or OM11 is installed on the F02 and this card features Bluetooth interface, the actuator configuration can be performed by means of the 'A Manager' software installed on the PDA or PC.

Only Blinker / Local Selector relay cannot be configured by means 'A Manager' software. The relevant Instruction and Operating Manual is available with the 'A Manager' software.

WARNING

The controls available via Bluetooth allow full actuator operability at a distance. Biffi will not accept any responsibility for damages or injuries caused by an improper use of your Bluetooth PDA.

6.4 HARDWARE CONFIGURATION FOR MONITOR RELAY

The Monitor Relay indicates the followings failures:

- Loss of power
- Stop by Torque out of limits
- Direction failure
- Temperature too high
- Position sensor failure
- Local control panel with selector in local position
- Valve jammed
- Hardware malfunction
- Alarm on the local control panel (if present)
- Stroke failure

The Monitor Relay contacts can be set as CLOSE or OPEN by changing the welding of JUMPER J1 on logic board.

As a default setting, pins 2 and 3 are welded together, and the Monitor Relay contact operates as follows:

- contact CLOSE in normal condition with relay energized, and OPEN in case of malfunction (relay is de-energized).

In case of request, if contact must be OPEN in normal condition and CLOSE in case of malfunction, the contact of JUMPER J1 must be modified welding pins 1 and 2 together.

WARNING

Configuration of Monitor Relay by means JUMPER J1 is a hardware configuration. For this reason, to configure Monitor Relay is mandatory manage actuator without power supply.

7. MAINTENANCE AND TROUBLESHOOTING

7.1 MAINTENANCE

7.1.1 Routine maintenance

Approximately every 2 years:

Under normal operating conditions, the F02 is maintenance-free: no actuator maintenance is formally required, even though visual inspection for grease leakage or external visible damages is recommended every two years. When conditions are severe (frequent operation or high temperatures), replace all seals that allow grease leakage or water inlet.

IMPORTANT

Before starting any maintenance operation, make sure that the mains and all other service voltage connected to the terminal board are switched-off.

The following checks will assure optimum performance:

- Make sure there are no grease leaks from the actuator housing
- Check the external parts for possible damage and replace them immediately, if necessary. In case the window glass is broken, the complete cover must be replaced (see Chapter 8 for individual item numbers)
- Repaint all areas where paint is missing. In chemically aggressive or saline environments, remove rust from surfaces and protect with a rust preventative
- Check that all nuts and bolts securing the actuator to the valve are tight. If necessary, re-tighten with a dynamometric key
- For severe applications or if actuator operation is infrequent, perform maintenance checks more often

7.1.2 Special maintenance

In case of actuator failure, please refer to Section 'Trouble shooting', Chapter 7.2, for possible causes.

Spare parts can be required from Biffi: please refer to the individual item number shown in Chapter 8.

In case of malfunction in the mechanical / electronic components, in case of grease leaks through the seals or in case of scheduled preventive maintenance, the actuator must be disassembled: any damaged parts can be requested from Biffi with reference to the attached exploded view drawings and parts lists.

It is essential that for every component to be required from Biffi the serial number of the actuator together with the item number of the component are indicated in the request.

IMPORTANT

After maintenance work a few operations must be performed to make sure that movement is regular and there is no grease leakage through the seals.

Note: Special maintenance is also recommended when, during operations, the actuator generates an excessive noise.

7.2 TROUBLE-SHOOTING

All F02 actuators have passed the functional test performed by Biffi Quality Assurance personnel.

If the actuator does not work, before troubleshooting make sure that:

- The main supply is the same as stated in the name plate menu
- The green LED for available power supply is switched on
- Power supply is available to the actuator and no protective device has declutched in the plant
- Check the position of the dip switch SW3; it must be '1'

7.2.1 The electronics do not switch on when powered

- Check that the value of the main voltage on terminals L1 and L2 (and in the same case L3) is correct
- Remove the cover assembly
- Check the continuity of the wires between terminals L1, L2, L3 and the connector of the power card
- If there is no continuity on the L1-L2-L3 cables, replace the terminal board
- If continuity on the L1, L2, L3 cables is ok, replace the entire drive and control unit

7.2.2 24 V DC output voltage not available at the terminals

- Switch the main power supply off and disconnect all wires from terminals 33 and 34
- Switch the main power supply on and check if the voltage on terminals 33 and 34 is between 22 and 26 V DC
- If the voltage is correct check the external wiring and the electrical load. It should not exceed 4 W
- If the voltage is not correct, replace the entire drive and control unit

7.2.3 The actuator does not work from remote controls

Check that:

- The wiring to terminals 32, 35 and 36 is correct
- There is no short circuit between wires
- The electrical load does not exceed 4 W
- If external voltage is used, the value has to be in the 24-120 V AC/DC range

7.2.4 The motor is very hot and does not start

- Wait until the motor cools down before trying to operate the actuator again
- Check that the number of operations per hour and their duration is suitable for the actuator service (see the name-plate)
- Check that the valve operating torque is within the range of the unit's designed operating torque
- Always check the causes of abnormal operation

7.2.5 The motor runs but the actuator does not move the valve

- Verify that the drive insert correctly fits in the actuator base
- Verify that the drive insert has enough engagement with the valve stem
- Verify that the key correctly fits in bore/keyways applications
- Check that the valve works in manual operation. If not, it is necessary to check the manual control area as follows:
 - Loosen the handwheel security dowel
 - Remove the handwheel
 - Check the integrity of the internal parts
 - Proceeding with the assembly, follow the reverse order of the disassembly
 - Make sure there are no foreign bodies. Pay attention not to damage the O-ring seals

7.2.6 The valve does not seat correctly

- If the valve is stopped by torque in closing, increase the actuator output torque limit
- If the valve is stopped by position in closing, check that the valve reaches its seat position, then readjust the setting of the position limit
- The internal trim of the valve may be damaged

7.2.7 Excessive torque for valve operation

- Clean, lubricate and check the valve stem
- Valve packing too tight: loosen the gland bolt nuts
- Check that the internal valve trim or the reducer gears are well lubricated and not damaged

7.2.8 The actuator does not stop in fully open or fully closed position

- Check that the actual open and close positions of the valve respectively correspond to 100% and 0%
- Make sure that the torque and travel limits are correctly set (see Chapter 6)

8. DECOMMISSIONING

8.1 DISPOSAL AND RECYCLING

At the end of the life of F02, the device must be disassembled.

Do not dump non-biodegradable products, lubricants and non-ferrous materials (rubber, PVC, resins etc.) into the environment. Dispose of all such materials as indicated in the following table:

WARNING

Do not re-use parts or components which appear to be in good condition after they have been checked or replaced by qualified personnel and declared unsuitable for use.

IMPORTANT

In all cases check local authority regulation before disposal.

Subject	Hazardous	Recyclable	Disposal
Electrical and electronic equipment	Yes	Yes	Use specialist recyclers
Glass	No	Yes	Use specialist recyclers
Metals	No	Yes	Use licensed recyclers
Plastics	No	Yes	Use specialist recyclers
Rubber (seals and O-rings)	Yes	No	Will require special treatment before disposal, use specialist waste disposal companies
Oil and grease	Yes	Yes	Will require special treatment before disposal, use specialist recyclers or waste disposal companies
Batteries	Yes	Yes	Will require special treatment before disposal, use specialist recyclers or waste disposal companies

9. PARTS LIST AND DRAWINGS

This section includes the drawings and parts list of each component and subassembly of F02 actuators.

IMPORTANT

When ordering spare parts, please indicate the serial number embossed on the actuator nameplate.

IMPORTANT

When ordering spare parts, please refer to the marked part list items on the attached drawings.

IMPORTANT

*Recommended spares for routine maintenance are marked with this sign * on parts list.*

F02 QUARTER-TURN ELECTRIC ACTUATOR

INSTALLATION & MAINTENANCE INSTRUCTIONS

F02 MODEL 063 - GENERAL ASSEMBLY

Pos.	Description	Quant.
1	Nut UNI5588-M6	2
2	Nut UNI5588-M8	2
3	Eccentric	1
4	Planocentric gear	2
5	Spacer	1
6	Ball bearing type 16002	1
7	Ball bearing type 16004	2
8	Ball bearing type 6001	1
9	ESH screw UNI5931-M6x8	1
10	HSHC screw UNI5931-M6x16	4
11	HSHC screw UNI5931-M4x14	7
12	HSHC screw UNI5931-M6x18	2
13	HSHC screw UNI5931-M6x25	4
14	HSHC screw UNI5931-M8x20	4
15	HSSC screw UNI5933-M4x10	1
16	Cover assembly	1
17	Drive and control unit	1
18	Handwheel	1
19	Output drive assembly	1
20	Standard housing	1
21	Stopper	2
22	Terminal block	1
23	Worm shaft flange	1
24	Anti-loosening washer UNI8842-J6	1
25	Base plate ISO 5211 / F05-F07	1
26	Cover gasket	1*
27	Dowel pin UNI EN 22338	1
28	Earth stud	1
29	Fixed anulus	1
30	Gasket	1*
31	Indicator	1
32	Indicator shaft	1
33	Manual worm shaft	1
34	Motor pinion	1
35	O-ring Di=10.77/W=2.62	1*
36	O-ring Di=18.77/W=1.78	1*
37	O-ring Di=52.07/W=2.62	1*
38	O-ring Di=6.07/W=1.78	1*
39	Plug	1
40	Position label	1
41	Power clamps protection	1
42	Ring	2
43	Ring for pins alignment	1
44	Ring RW 7 UNI7433	2
45	Seal washer 8.3	2
46	Sliding ring	1
47	Snap ring for shaft D.6	1
48	Terminal block cover	1
49	Terminal board gasket	1*
50	Wheel	1

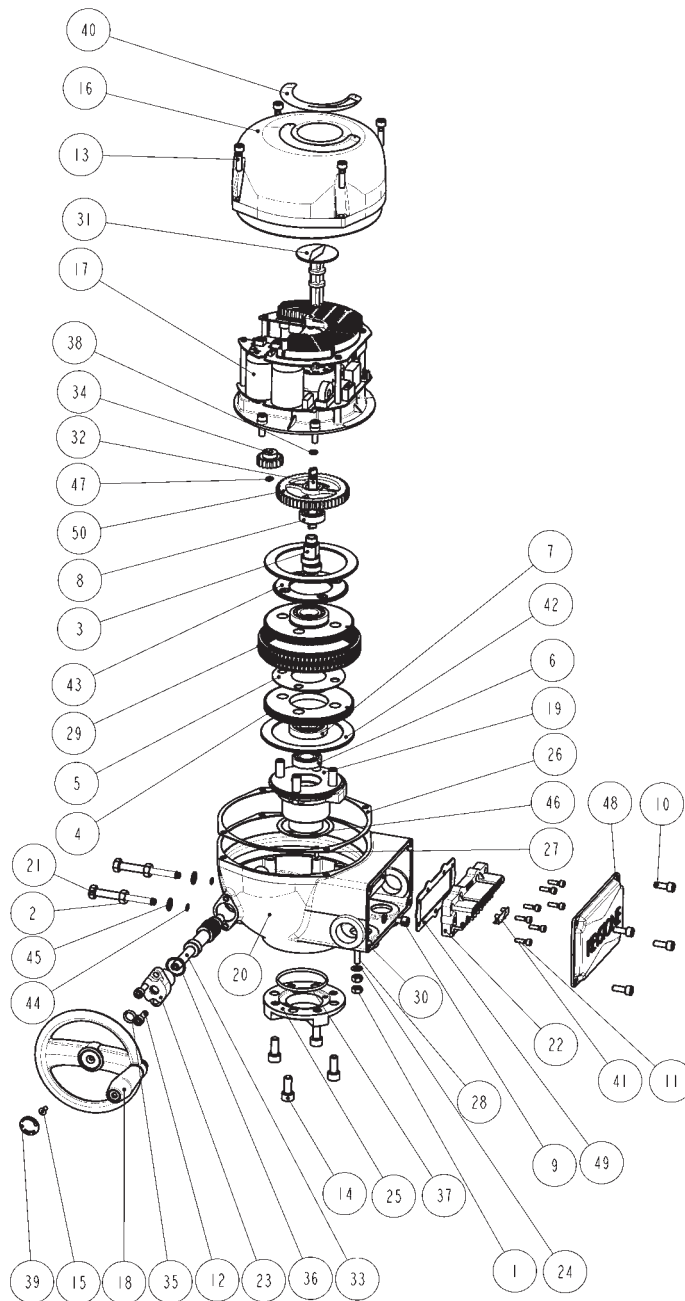

* Indicates recommended spare parts

F02 QUARTER-TURN ELECTRIC ACTUATOR

INSTALLATION & MAINTENANCE INSTRUCTIONS

F02 MODEL 125 - GENERAL ASSEMBLY

Pos.	Description	Quant.
1	Nut UNI5588-M6	2
2	Nut UNI5588-M8	2
3	Eccentric	1
4	Planocentric gear	2
5	Spacer	1
6	Ball bearing type 16002	1
7	Ball bearing type 16004	2
8	Ball bearing type 6001	1
9	ESH screw UNI5931-M6x8	1
10	HSHC screw UNI5931-M6x16	4
11	HSHC screw UNI5931-M4x14	7
12	HSHC screw UNI5931-M6x18	2
13	HSHC screw UNI5931-M6x25	4
14	HSHC screw UNI5931-M8x20	4
15	HSSC screw UNI5933-M4x10	1
16	Cover assembly	1
17	Drive and control unit	1
18	Handwheel	1
19	Output drive assembly	1
20	Standard housing	1
21	Stopper	2
22	Terminal block	1
23	Worm shaft flange	1
24	Anti-loosening washer UNI8842-J6	1
25	Base plate ISO 5211 / F07-F10	1
26	Cover gasket	1*
27	Dowel pin UNI EN 22338	1
28	Earth stud	1
29	Fixed anulus	1
30	Gasket	1*
31	Indicator	1
32	Indicator shaft	1
33	Manual worm shaft	1
34	Motor pinion	1
35	O-ring Di=10.77/W=2.62	1*
36	O-ring Di=18.77/W=1.78	1*
37	O-ring Di=52.07/W=2.62	1*
38	O-ring Di=6.07/W=1.78	1*
39	Plug	1
40	Position label	1
41	Power clamps protection	1
42	Ring	2
43	Ring for pins alignment	1
44	Ring RW 7 UNI7433	2
45	Seal washer 8.3	2
46	Sliding ring	1
47	Snap ring for shaft D.6	1
48	Terminal block cover	1
49	Terminal board gasket	1*
50	Wheel	1

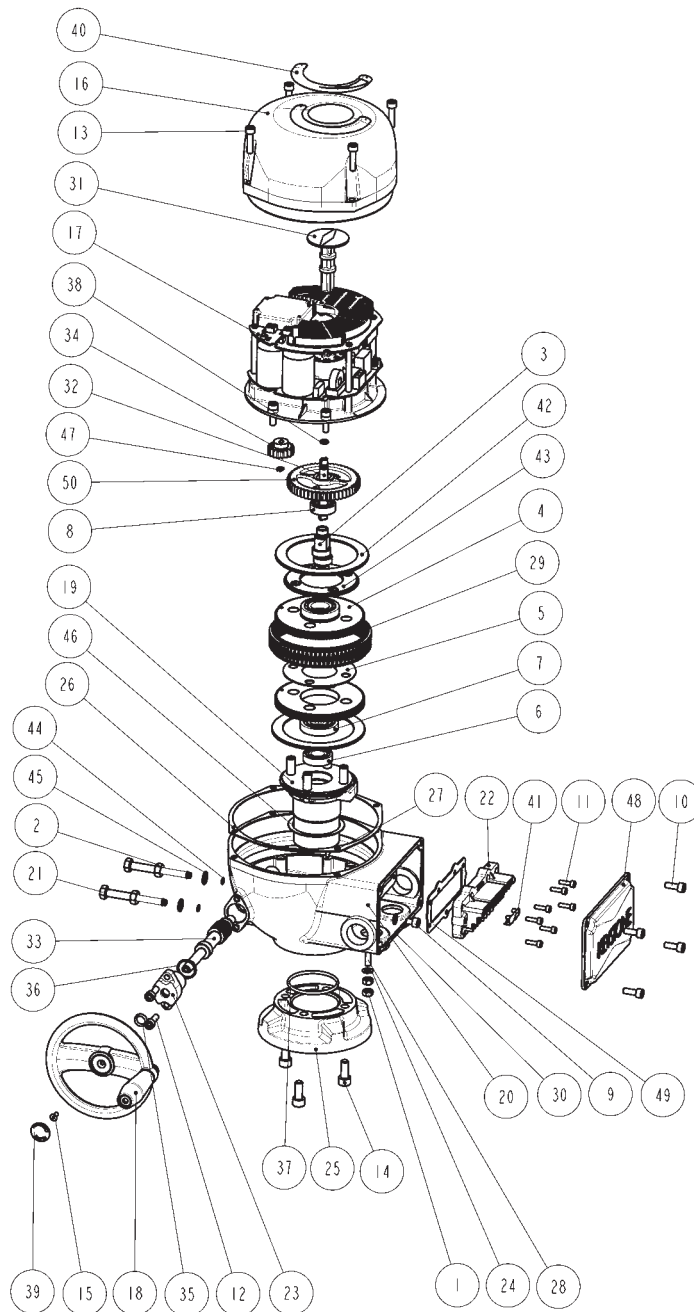

* Indicates recommended spare parts

F02 QUARTER-TURN ELECTRIC ACTUATOR

INSTALLATION & MAINTENANCE INSTRUCTIONS

F02 MODEL 250 - GENERAL ASSEMBLY

Pos.	Description	Quant.
1	Nut UNI5588-M12	2
2	Nut UNI5588-M6	2
3	Eccentric	1
4	Planocentric gear	2
5	Spacer	1
6	Ball bearing type 6005	2
7	Ball bearing type 6202	1
8	Ball bearing type 16002	1
9	ESH screw UNI5931-M6x8	1
10	HSCH screw UNI5931-M6x16	4
11	HSCH screw UNI5931-M10x25	4
12	HSCH screw UNI5931-M4x14	7
13	HSCH screw UNI5931-M6x20	2
14	HSCH screw UNI5931-M6x25	4
15	HSSC screw UNI5933-M4x10	1
16	HSSC screw UNI5933-M5x12	3
17	Cover assembly	1
18	Handwheel	1
19	Housing	1
20	Motor pinion	1
21	Output drive assembly	1
22	Stopper	2
23	Terminal block	1
24	Anti-loosening washer UNI8842-J6	2
25	Base plate ISO 5211 F07-F10-F12	1
26	Cover gasket	1*
27	Dowel pin UNI EN 22338	1
28	Earth stud	1
29	Fixed anulus	1
30	Gasket	1*
31	Indicator	1
32	Indicator shaft	1
33	Manual worm shaft	1
34	O-ring Di=10.77/W=2.62	1*
35	O-ring Di=18.77/W=1.78	1*
36	O-ring Di=6.07/W=1.78	1*
37	O-ring Di=69.52/W=2.62	1*
38	Plug	1
39	Position label	1
40	Power clamps protection	1
41	Ring	1
42	Ring for pins alignment	1
43	Ring RW 10 UNI7433	2
44	Seal washer 12.3	2
45	Sliding ring	1
46	Snap ring for shaft D.12	1
47	Terminal block cover	1
48	Terminal board gasket	1*
49	Wheel	1
50	Worm shaft flange	1
51	Drive and control assembly	1

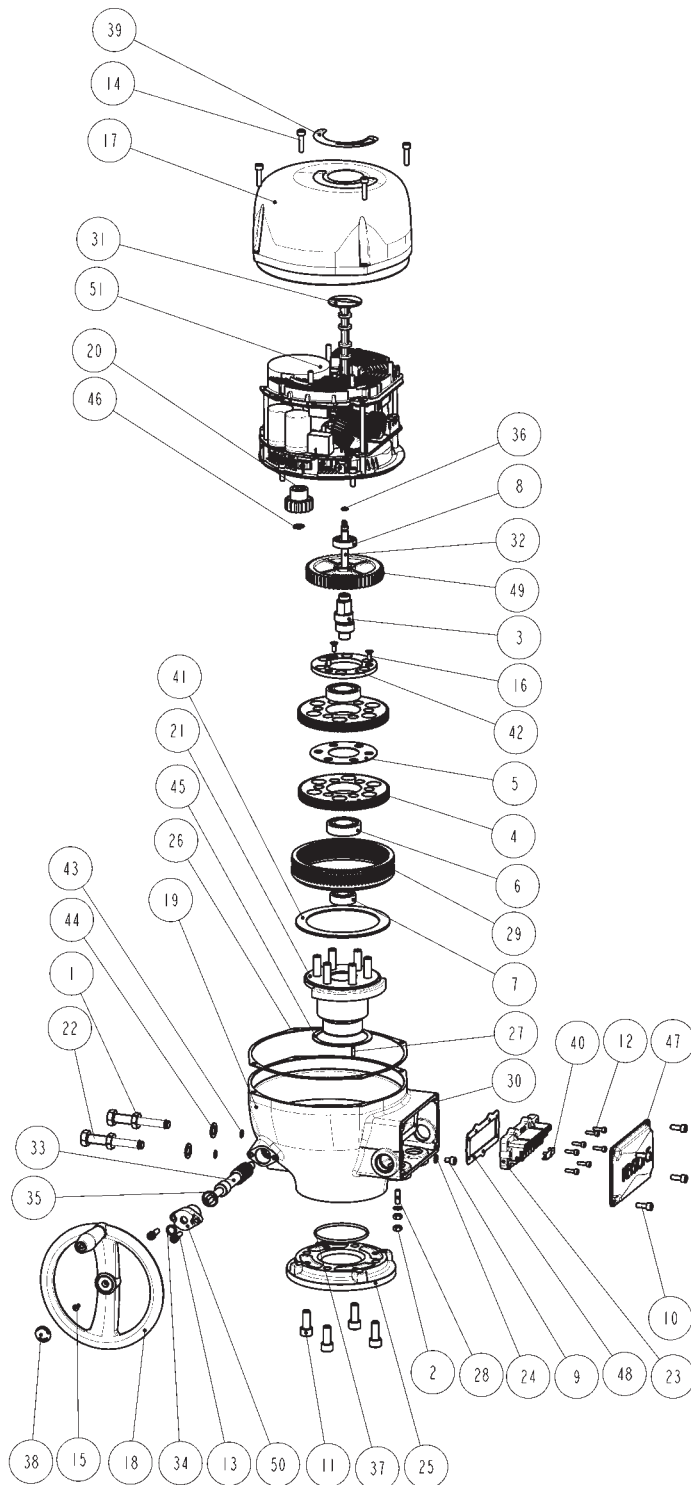

* Indicates recommended spare parts

F02 QUARTER-TURN ELECTRIC ACTUATOR

INSTALLATION & MAINTENANCE INSTRUCTIONS

F02 MODEL 500 - GENERAL ASSEMBLY

Pos.	Description	Quant.
1	Nut UNI5588-M12	2
2	Nut UNI5588-M6	2
3	Eccentric	1
4	Planocentric gear	2
5	Spacer	1
6	Ball bearing type 6005	2
7	Ball bearing type 6202	1
8	Ball bearing type 16002	1
9	ESH screw UNI5931-M6x8	1
10	HSHC screw UNI5931-M6x16	4
11	HSHC screw UNI5931-M10x25	4
12	HSHC screw UNI5931-M4x14	7
13	HSHC screw UNI5931-M6x20	2
14	HSHC screw UNI5931-M6x25	4
15	HSSC screw UNI5933-M4x10	1
16	HSSC screw UNI5933-M5x12	3
17	Cover assembly	1
18	Drive and control assembly	1
19	Handwheel	1
20	Housing	1
21	Motor pinion	1
22	Output drive assembly	1
23	Stopper	2
24	Terminal block	1
25	Anti-loosening washer UNI8842-J6	2
26	Base plate ISO 5211 F10-F12	1
27	Cover gasket	1*
28	Dowel pin UNI EN 22338	1
29	Earth stud	1
30	Fixed anulus	1
31	Gasket	1*
32	Indicator	1
33	Indicator shaft	1
34	Manual worm shaft	1
35	O-ring Di=10.77/W=2.62	1*
36	O-ring Di=18.77/W=1.78	1*
37	O-ring Di=6.07/W=1.78	1*
38	O-ring Di=69.52/W=2.62	1*
39	Plug	1
40	Position label	1
41	Power clamps protection	1
42	Ring	1
43	Ring for pins alignment	1
44	Ring RW 10 UNI7433	2
45	Seal washer 12.3	2
46	Sliding ring	1
47	Snap ring for shaft D.12	1
48	Terminal block cover	1
49	Terminal board gasket	1*
50	Wheel	1
51	Worm shaft flange	1

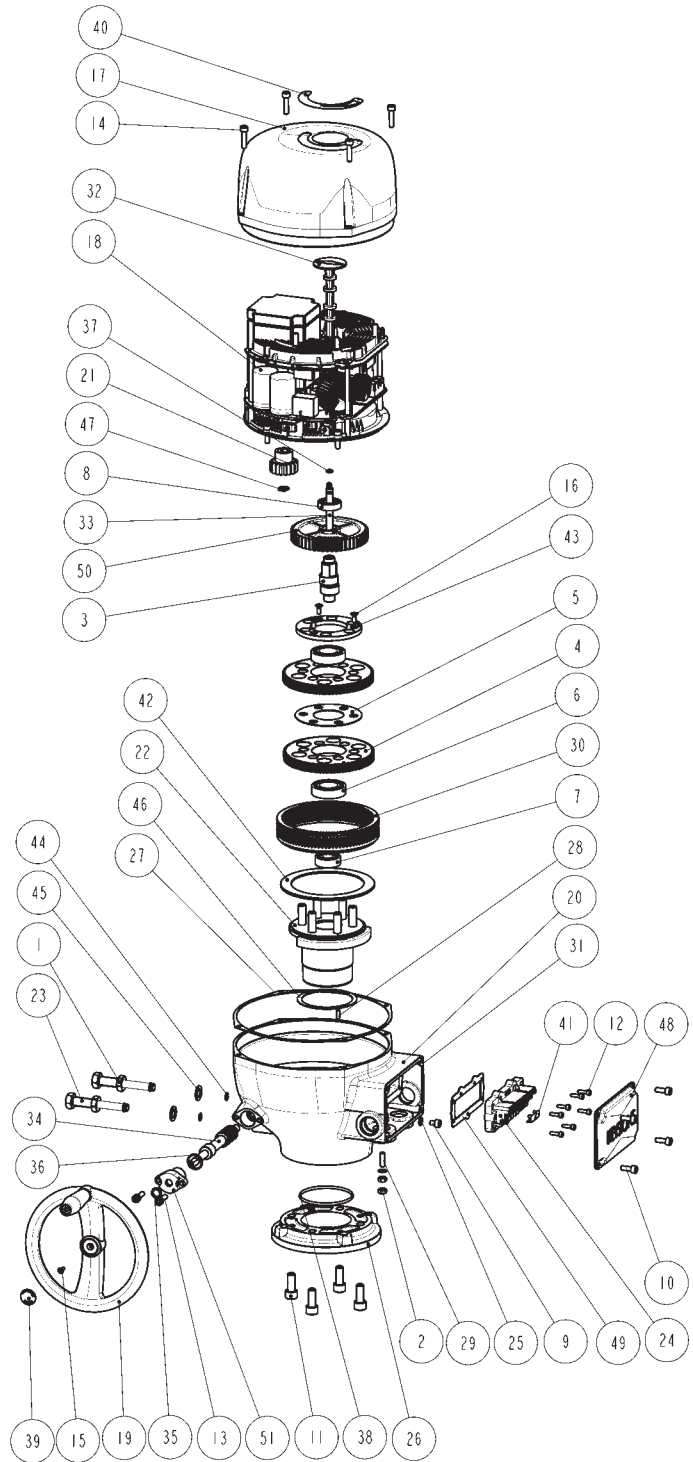

* Indicates recommended spare parts

F02 QUARTER-TURN ELECTRIC ACTUATOR

INSTALLATION & MAINTENANCE INSTRUCTIONS

F02 MODEL 1.000 - GENERAL ASSEMBLY

Pos.	Description	Quant.
1	Nut UNI5588-M16	2
2	Nut UNI5588-M6	2
3	Eccentric	1
4	Planocentric gear	2
5	Spacer	1
6	Ball bearing type 6305	2
7	Ball bearing type 16002	1
8	Ball bearing type NJ202ECP	1
9	ESH screw UNI5931-M6x8	1
10	HSCH screw UNI5931-M12x65	4
11	HSCH screw UNI5931-M4x14	7
12	HSCH screw UNI5931-M6x25	4
13	HSCH screw UNI5931-M8x25 A4-70	2
14	HSSC screw UNI5933-M6x20	1
15	HSSC screw UNI5933-M4x10	1
16	HSSC screw UNI5933-M5x12	3
17	Cover assembly	1
18	Drive and control assembly	1
19	Handwheel assembly	1
20	Output drive assembly	1
21	Stopper	2
22	Terminal block	1
23	Terminal cover gasket	2*
24	Anti-loosening washer UNI8842-J6	2
25	Base plate ISO 5211 F10-F14	1
26	Cover gasket	1*
27	Dowel pin UNI EN 22338	1
28	Earth stud	1
29	Fixed anulus	1
30	Housing	1
31	Indicator	1
32	Indicator shaft	1
33	Manual worm shaft	1
34	Motor pinion	1
35	O-ring Di=13.94/W=2.62	1*
36	O-ring Di=25.12/W=1.78	1*
37	O-ring Di=6.07/W=1.78	1*
38	O-ring Di=82.22/W=2.62	1*
39	Plug	1
40	Position label	1
41	Power clamps protection	1
42	Ring	1
43	Ring for pins alignment	1
44	Ring RW 14 UNI7433	2
45	Seal washer 16,3	2
46	Sliding ring	2
47	Terminal board gasket	1*
48	Washer	1
49	Wheel	1
50	Worm shaft flange	1
51	Terminal block cover	1
52	HSCH screw UNI5931-M6x18	4

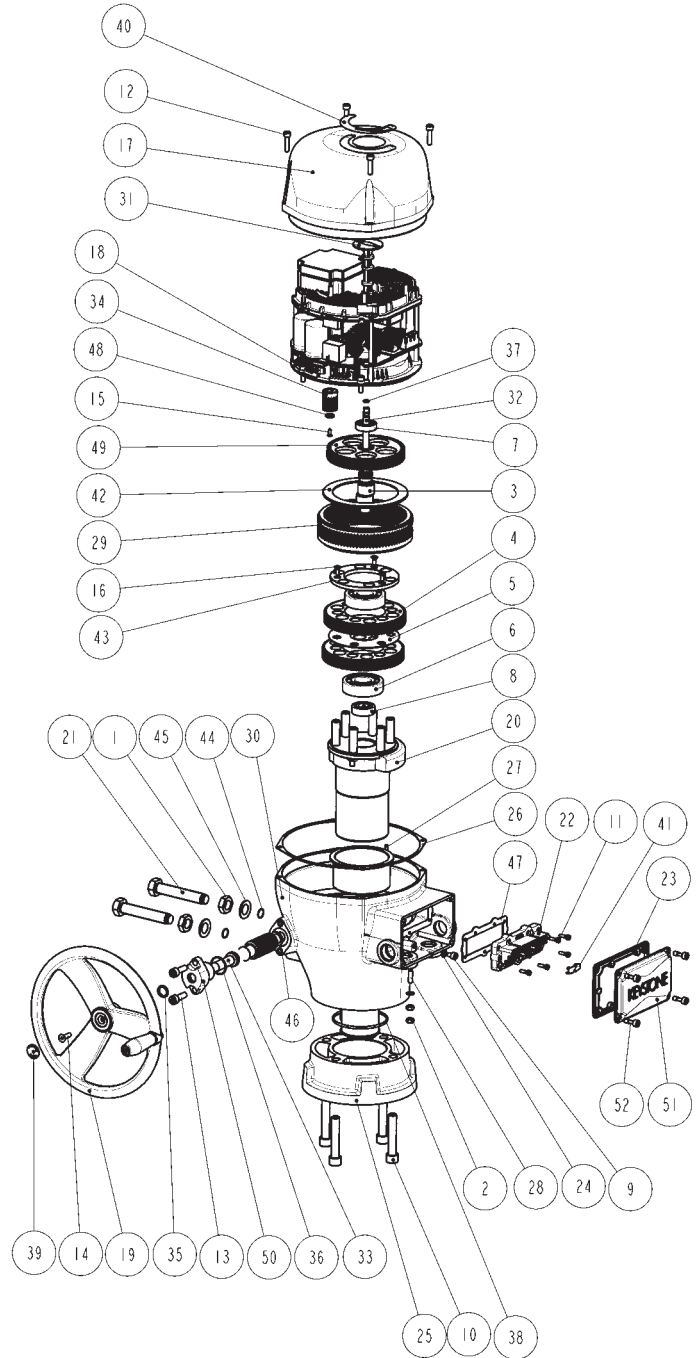

* Indicates recommended spare parts

F02 QUARTER-TURN ELECTRIC ACTUATOR

INSTALLATION & MAINTENANCE INSTRUCTIONS

F02 MODEL 2.000 (GEAR REDUCER) - GENERAL ASSEMBLY

Pos.	Description	Quant.
1	Nut M20 ISO 4032 EN 24032	2
2	Ball bearing type 6006	1
3	Ball bearing type 16004	1
4	Ball bearing type 61908	1
5	HSHC screw UNI5931-M6x16	3
6	HSHC screw UNI5931-M12x30	4
7	HSHC screw UNI5931-M12x65	4
8	HSHC screw UNI5931-M8x25 A4-70	6
9	F02 actuator	1
10	Base housing	1
11	Base plate F12-F16 EN ISO 5211	1
12	Bearing support	1
13	Bushing	2
14	Bushing	1
15	Bushing	1
16	Bushing	1
17	Dowel pin UNI EN 22338 D.8x20 type B	4
18	Gasket	1*
19	Hex head screw UNI EN 24017-M20x80	2
20	Idle wheel shaft	1
21	Needle bearing type NKI 22/16	2
22	O-ring Di=82.22/W=2.62	1*
23	Position wheel	1
24	Seal washer 20.3	2
25	Sector gear	1
26	Sliding ring	1
27	Upper cover	1
28	Wheel	2

* Indicates recommended spare parts

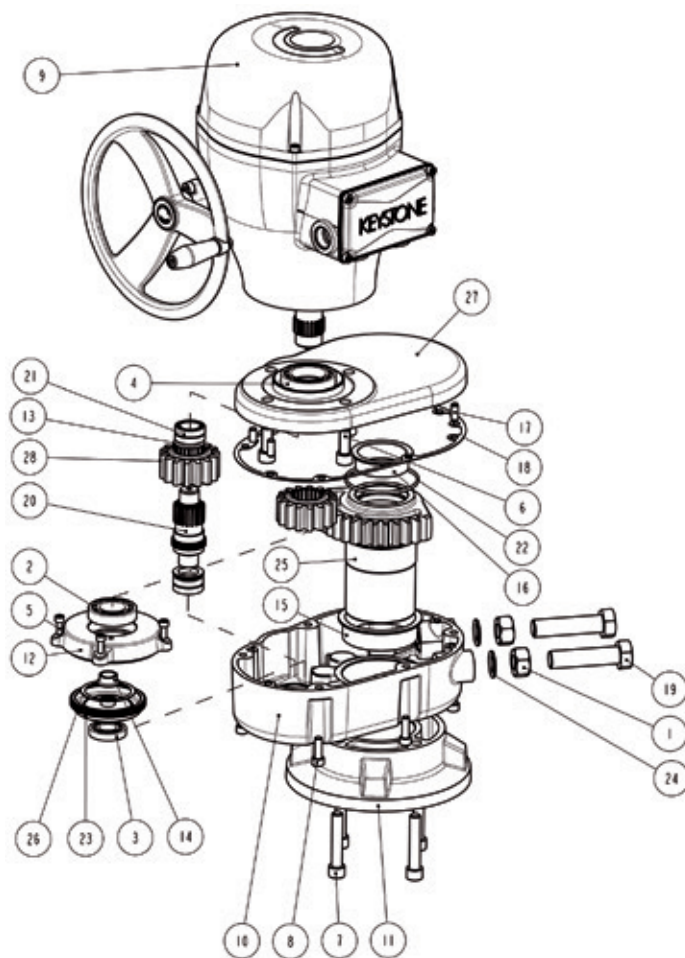

F02 QUARTER-TURN ELECTRIC ACTUATOR

INSTALLATION & MAINTENANCE INSTRUCTIONS

F02 MODEL 2.000 (ACTUATOR) - GENERAL ASSEMBLY

Pos.	Description	Quant.
1	Nut UNI5588-M6	2
2	Eccentric	1
3	Planocentric gear	2
4	Spacer	1
5	Ball bearing type 6305	2
6	Ball bearing type 16002	1
7	Roller bearing type NJ202ECP	1
8	ESH screw UNI5931-M6x8	1
9	HSCH screw UNI5931-M4x14	7
10	HSCH screw UNI5931-M6x25	4
11	HSCH screw UNI5931-M8x25 A4-70	2
12	HSSC screw UNI5933-M6x20	1
13	HSSC screw UNI5933-M4x10	1
14	HSSC screw UNI5933-M5x12	3
15	Cover assembly	1
16	Drive and control assembly	1
17	Handwheel assembly	1
18	Housing	1
19	Output drive assembly	1
20	Terminal block	1
21	Terminal cover gasket	1*
22	Worm shaft flange	1
23	Anti-loosening washer UNI8842-J6	2
24	Bushing	1
25	Cover gasket	1*
26	Dowel pin UNI EN 22338	1
27	Earth stud	1
28	Fixed anulus	1
29	Hex head screw UNI EN 24017-M16x30	2
30	Indicator	1
31	Indicator shaft	1
32	Manual worm shaft	1
33	Motor pinion	1
34	O-ring Di=13.94/W=2.62	1*
35	O-ring Di=25.12/W=1.78	1*
36	O-ring Di=6.07/W=1.78	1*
37	O-ring Di=82.22/W=2.62	1*
38	Plug	1
39	Position label	1
40	Power clamps protection	1
41	Ring	1
42	Ring for pins alignment	1
43	Seal washer 16.3	2
44	Terminal board gasket	1*
45	Washer	1
46	Wheel	1
47	Terminal block cover	1
48	HSCH screw UNI5931-M6x18	4

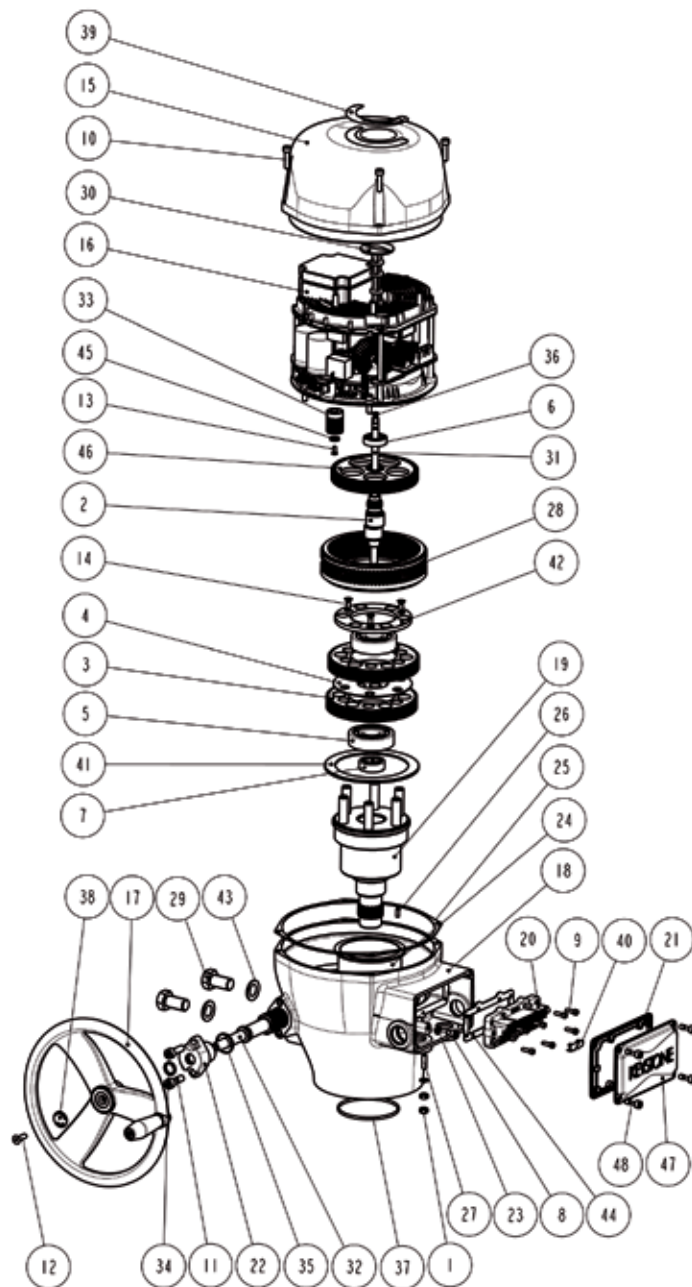

* Indicates recommended spare parts