

T208 Series Tank Blanketing Vapor Recovery Regulators



Figure 1. Type T208 Tank Blanketing Vapor Recovery Regulator

Contents

Features	1
Introduction.....	2
Specifications	2
Principle of Operation.....	2
Installation	4
Overpressure Protection.....	4
Capacity Information.....	5
Ordering Information.....	7
Ordering Guide	7

Features

- **Accurate Control**—Large diaphragm area provides very accurate throttling control at low pressure settings.
- **Easy Conversion**—Changes easily from the Type T208 to the Type T208M with two O-rings and a machine screw.
- **Rugged Construction**—Heavy duty casings and internal parts are designed to reduce vibration and shock and give this regulator the ability to withstand up to 35 psig / 2.4 bar (with Nitrile (NBR) and Fluorocarbon (FKM) diaphragms) and 10 psig / 0.69 bar (with Fluorinated Ethylene Propylene (FEP) diaphragm) with no internal parts damage.
- **Simplicity**—Direct-operated, straightforward stem and lever design minimizes the number of parts while providing excellent regulation of pressure.
- **Sour Gas Service Capability**—Available construction to meet NACE MR0175-2002.



Bulletin 74.2:T208

Specifications

This section lists the specifications of the T208 Series Tank Blanketing Vapor Recovery Regulator. Factory specification, such as maximum temperature, maximum inlet and outlet pressures, spring range and seat or orifice size are stamped on the nameplate fastened on the regulator at the factory.

Available Configurations

Type T208: Tank Blanketing Vapor Recovery regulator with control pressure range of 2 in.w.c. to 7 psig / 5 mbar to 0.48 bar in six different spring ranges and has internal pressure registration requiring no control line.

Type T208M: Similar to Type T208 but has a blocked throat and a control line connection for external pressure registration.

Body Sizes and End Connection Styles

See Table 1

Maximum Allowable Inlet (Casing) Pressure⁽¹⁾

See Table 1

Maximum Outlet Pressure⁽¹⁾

35 psig / 2.4 bar

Maximum Emergency Inlet Pressure to Avoid Internal Parts Damage⁽¹⁾

With Nitrile (NBR) or Fluorocarbon (FKM) diaphragm: 35 psig / 2.4 bar

With Fluorinated Ethylene Propylene (FEP) diaphragm: 10 psig / 0.69 bar

Control Pressure Ranges⁽¹⁾

See Table 3

Flow and Sizing Coefficients

See Table 4

C_v Coefficients and Flow Capacities

See Table 5

Orifice Size

7/16 in. / 11 mm

Body and Casing Materials

Gray Cast Iron, WCC Carbon Steel and CF8M/CF3M Stainless Steel⁽²⁾

Trim Materials

See Table 2

Material Temperature Capabilities⁽¹⁾⁽³⁾

Elastomer Parts

Nitrile (NBR): -40 to 180°F / -40 to 82°C

Fluorinated Ethylene Propylene (FEP): -20 to 180°F / -29 to 82°C

Fluorocarbon (FKM): 40 to 300°F / 4 to 149°C

Ethylene Propylene Diene (EPDM): -20 to 225°F / -29 to 107°C

Perfluoroelastomer (FFKM): 0 to 300°F / -18 to 149°C

Body Materials

Gray Cast Iron: -20 to 300°F / -29 to 149°C

WCC Carbon Steel: -20 to 300°F / -29 to 149°C

CF8M/CF3M Stainless Steel: -40 to 300°F / -40 to 149°C

Spring Case Vent Connection

1/4 NPT

Diaphragm Case Control Line Connection (Type T208M)

1/2 NPT

Approximate Weight

17.7 lbs / 8 kg

1. The pressure/temperature limits in this Bulletin and any applicable standard or code limitation should not be exceeded.

2. Pipe nipples and flanges are 316 Stainless steel for flanged body assemblies.

3. See Table 2 for operating temperature ranges for available trim combinations.

Table 1. Body Sizes, End Connection Styles and Maximum Allowable Inlet (Casing) Pressures

BODY SIZE		BODY MATERIAL	END CONNECTION STYLE ⁽¹⁾	MAXIMUM ALLOWABLE INLET (CASING) PRESSURE	
In.	DN			psig	bar
3/4 or 1	20 or 25	Gray cast iron	NPT	35	2.4
		WCC Carbon steel	NPT, CL150 RF, CL300 RF or PN 16/25/40 RF	75	5.2
		CF8M/CF3M Stainless steel ⁽²⁾			

1. All flanges are welded. Weld-on flange dimension is 14 in. / 356 mm face-to-face.

2. Pipe nipples and flanges are 316 Stainless steel for flanged body assemblies.

Introduction

The T208 Series are direct-operated tank blanketing vapor recovery regulators. These regulators are used to sense an increase in vessel pressure and vent excessive internal tank pressure to an appropriate vapor recovery disposal or reclamation system. T208 Series may also be used as backpressure regulators or relief valves.

Principle of Operation

Type T208 vapor recovery regulator senses the change in tank pressure internally (see Figure 2), while Type T208M

regulator senses the change in tank pressure through a 1/2 NPT control line tapped in its lower casing (see Figure 3).

When vessel pressure increases above the setpoint of the regulator due to thermal heating or pump-in of the product, the pressure on the diaphragm overcomes the force of the control spring. The disk moves away from the orifice, allowing gas to flow from the vessel to the vapor recovery system.

As vessel pressure is reduced, the force of the back disk spring causes the disk to move toward the orifice, decreasing the flow of gas out of the vessel. As vessel pressure drops below the setpoint of the regulator, the disk will seat against the orifice, shutting off the gas flow.

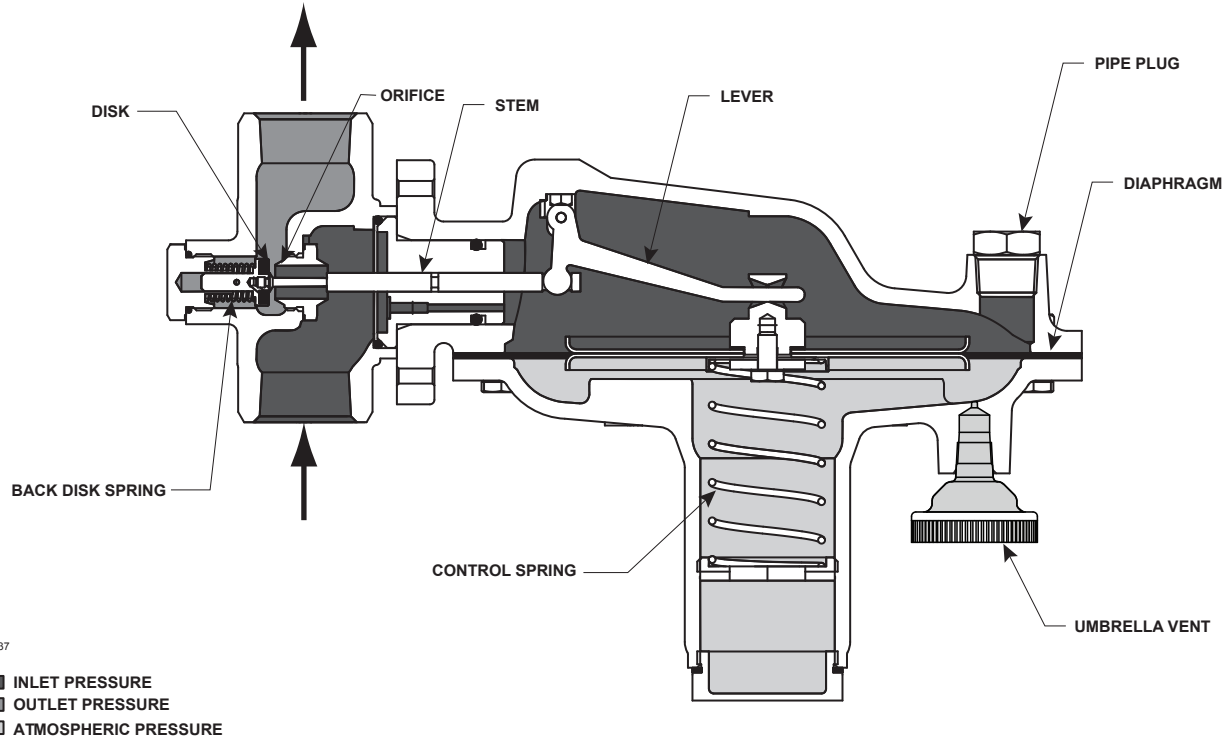

Figure 2. Type T208 with Internal Pressure Registration Operational Schematics

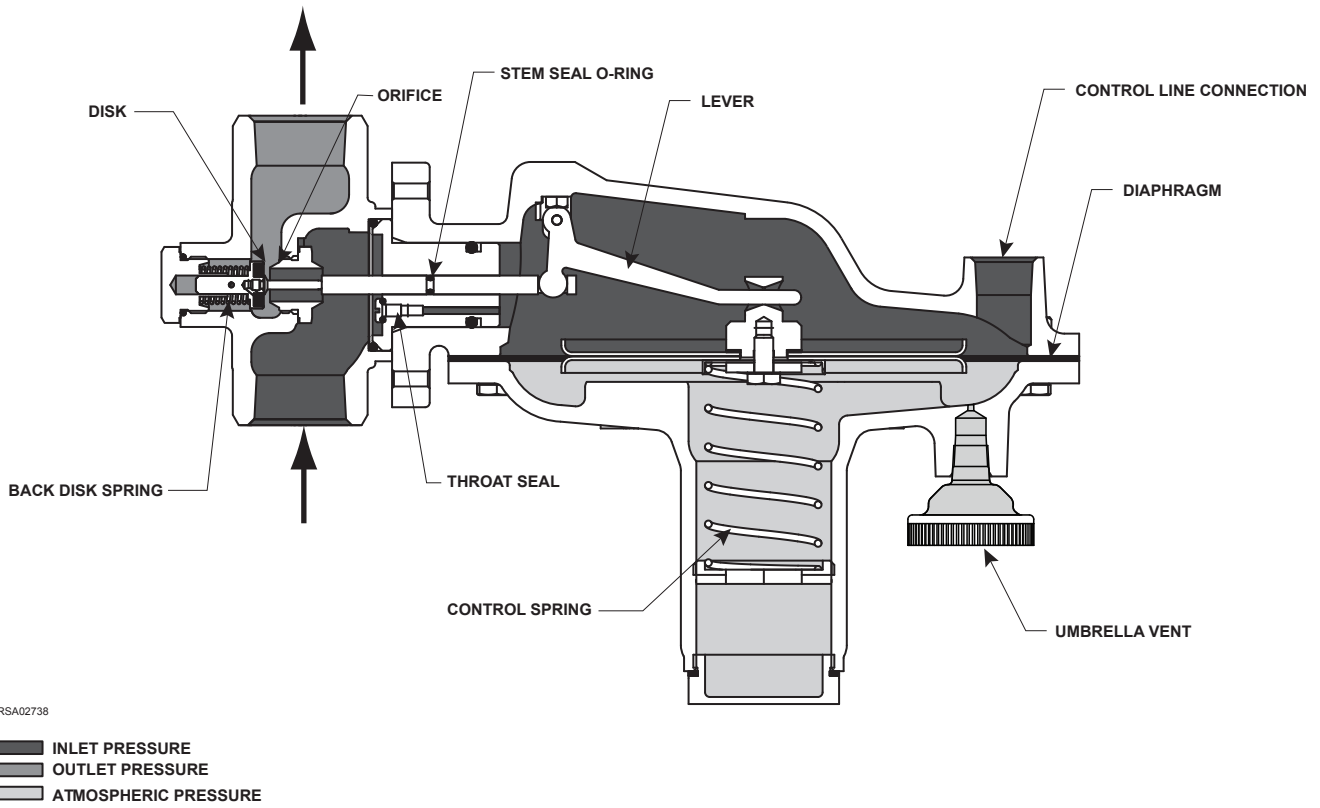

Figure 3. Type T208M with External Pressure Registration Operational Schematics

Bulletin 74.2:T208

Table 2. Available Construction and Trim Materials

AVAILABLE CONSTRUCTION MATERIAL				AVAILABLE TRIM OPTION			
Body and Casing	Guide Insert, Stem and Pusher Post	Diaphragm Head	Lever Assembly	Trim Option Code	Diaphragm Material	Disk and O-ring Material	Operating Temperature Range
Gray cast iron, WCC Carbon steel or CF8M/CF3M Stainless steel ⁽¹⁾	316 Stainless Steel	304 Stainless Steel	302 Stainless Steel	Standard	Nitrile (NBR)	Nitrile (NBR)	-40 to 180°F / -40 to 82°C
				VV	Fluorocarbon (FKM)	Fluorocarbon (FKM)	40 to 300°F / 4 to 149°C
				TV	Fluorinated Ethylene Propylene (FEP)	Fluorocarbon (FKM)	40 to 180°F / 4 to 82°C
				TN	Fluorinated Ethylene Propylene (FEP)	Nitrile (NBR)	-20 to 180°F / -29 to 82°C
				TK	Fluorinated Ethylene Propylene (FEP)	Perfluoroelastomer (FFKM)	0 to 180°F / -18 to 82°C
				TE	Fluorinated Ethylene Propylene (FEP)	Ethylene Propylene Diene (EPDM)	-20 to 180°F / -29 to 82°C

1. Pipe nipples and flanges are 316 Stainless steel for flanged body assemblies.

Table 3. Control Pressure Ranges and Spring Information

CONTROL PRESSURE RANGE		SPRING COLOR	SPRING WIRE DIAMETER		SPRING FREE LENGTH	
In. w.c.	mbar		In.	mm	In.	mm
2.0 to 7.0 ⁽¹⁾⁽²⁾	5 to 17 ⁽¹⁾⁽²⁾	Red	0.085	2.2	3.63	92.2
3.0 to 13.0 ⁽¹⁾⁽²⁾	7 to 32 ⁽¹⁾⁽²⁾	Unpainted	0.105	2.7	3.75	95.3
10.0 to 26.0	25 to 65	Yellow	0.114	2.9	4.31	109
0.9 to 2.5 psig	62 to 172	Green	0.156	4.0	4.06	103
1.3 to 4.5 psig	90 to 310	Light Blue	0.187	4.8	3.94	100
3.8 to 7.0 psig	0.26 to 0.48 bar	Black	0.218	5.5	3.98	101

1. To achieve the published control pressure range the spring case must be installed pointing down.
2. Do not use Fluorocarbon (FKM) diaphragm with these springs at diaphragm temperatures lower than 60°F / 16°C.

Table 4. Flow and Sizing Coefficients

ORIFICE SIZE		REGULATING			WIDE-OPEN		
In.	mm	C _g	C _v	C ₁	C _g	C _v	C ₁
7/16	11	94	2.7	35.0	97	2.8	35.0

Table 5. T208 Series C_v Coefficient and Flow Capacity

CONTROL PRESSURE RANGE AND SPRING COLOR	SET PRESSURE		MINIMUM BUILDUP TO WIDE-OPEN		VACUUM OUTLET PRESSURE		C _v COEFFICIENT	CAPACITIES OF AIR	
	In. w.c.	mbar	In. w.c.	mbar	psig	barg		SCFH	Nm ³ /h
	2.0 to 7.0 in. w.c. / 5 to 17 mbar Red	2.0	5.0	4.02	10	0		0	3.1
2.5						0.17	3.5	1161	31.1
5						0.34	3.5	1488	39.9
4.0		10.0	3.62	9	0	0	2.6	226	6.1
					2.5	0.17	3.5	1178	31.6
					5	0.34	3.5	1500	40.2
3.0 to 13.0 in. w.c. / 7 to 32 mbar Unpainted	10.0	25	5.99	15	0	0	2.0	268	7.2
					2.5	0.17	3.5	1232	33.0
					5	0.34	3.5	1539	41.2
10.0 to 26.0 in. w.c. / 25 to 65 mbar Yellow	15	37	8.89	22.1	0	0	2.0	331	8.9
					2.5	0.17	3.5	1279	34.3
					5	0.34	3.5	1574	42.2
0.9 to 2.5 psig / 62 to 172 mbar Green	1 psig	70	0.78 psig	54	0	0	2.2	499	13.4
					2.5	0.17	3.6	1426	38.2
					5	0.34	3.6	1687	45.2
1.3 to 4.5 psig / 90 to 310 mbar Light Blue	2 psig	140	1.49 psig	103	0	0	2.3	752	20.2
					2.5	0.17	3.8	1694	45.4
					5	0.34	3.7	1904	51.0
3.8 to 7.0 psig / 0.26 to 0.48 bar Black	5 psig	340	2.79 psig	192	0	0	2.2	1139	30.5
					2.5	0.17	3.8	2286	61.3
					5	0.34	3.8	2242	60.1

Installation

Install the T208 Series regulator using a straight run pipe of the same size or larger as the regulator body. Flow through the regulator body is indicated by the flow arrow attached to the body. If a block valve is required, install a full flow valve between the regulator and the blanketed vessel. To achieve the established regulator capacities, the regulators should be installed with the spring case barrel pointed down (See Figure 1).

Emerson Process Management Regulator Technologies, Inc. (Emerson™) provides an instruction manual with every

regulator shipped. Refer to this for complete installation, operation and maintenance instructions. Included is a complete listing of individual parts and recommended spare parts.

Overpressure Protection

Vapor recovery regulators are used to maintain a constant inlet (blanket) pressure with the outlet flowing to a system whose pressure is lower than that at the inlet. The recovery regulators are not intended to be used as an ASME certified relief device for overpressure protection on a tank. They are to

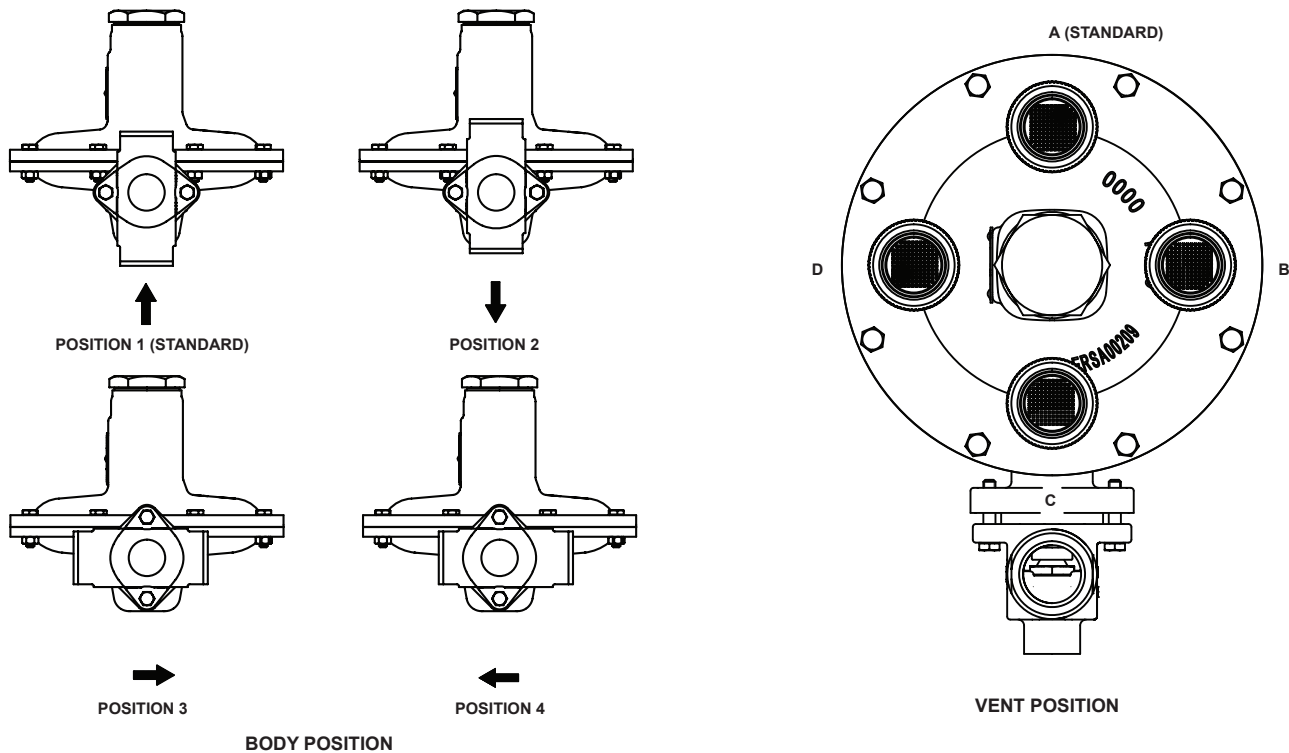

Figure 4. Body and Vent Position

be used as part of a gas blanketing system to control outflow of blanketing gas under normal conditions and collect tank vapors for the vapor disposal or reclamation system. Provide alternate methods of emergency overpressure protection.

Universal NACE Compliance

Optional materials are available for applications handling sour gases. These constructions comply with the recommendations of National Association of Corrosion Engineers (NACE) sour service standards.

The manufacturing processes and materials used by Emerson™ assure that all products specified for sour gas service comply with the chemical, physical and metallurgical requirements of NACE MR0175-2002. Customers have the responsibility to specify correct materials. Environmental limitations may apply and shall be determined by the user.

Sizing Blanketing Systems

When sizing a gas vapor recovery regulator system, consider the volume of blanketing gas that must be displaced from the vessel when either filling the vessel with liquid (pump-in) or the expansion of vapors inside the vessel during atmospheric thermal heating.

Using the established procedures from American Petroleum Institute Standard 2000 (API 2000), determine the flow rate for outbreathing:

$$Q_{total} = Q_{pump} + Q_{thermal}$$

where,

- Q_{total}: Required Flow Rate
- Q_{pump}: Required Flow Rate due to pump in
- Q_{thermal}: Required Flow Rate due to thermal heating

Capacity Information

Table 5 shows the T208 Series C_v coefficient and flow capacities of air at selected set pressure. Flows are in SCFH (at 60°F and 14.7 psia) and Nm³/h (at 0°C and 1.01325 bar) of 1.0 specific gravity air. For gases of other specific gravities, divide the given capacity of air by the square root of the appropriate specific gravity of the gas required. To determine regulating capacities at pressure settings not given or to determine wide-open flow capacities, use the following formula:

$$Q = \sqrt{\frac{520}{GT}} C_g P_1 \text{SIN} \left(\frac{3417}{C_1} \sqrt{\frac{\Delta P}{P_1}} \right) \text{DEG}$$

where:

- Q = flow rate, SCFH
- G = gas specific gravity
- T = absolute temperature of gas at inlet, °Rankine
- C_g = gas sizing coefficient, Table 4
- P₁ = absolute inlet pressure, psia
- C₁ = C_g/C_v, flow coefficient, Table 4
- ΔP = pressure drop across the regulator, psi

Bulletin 74.2:T208

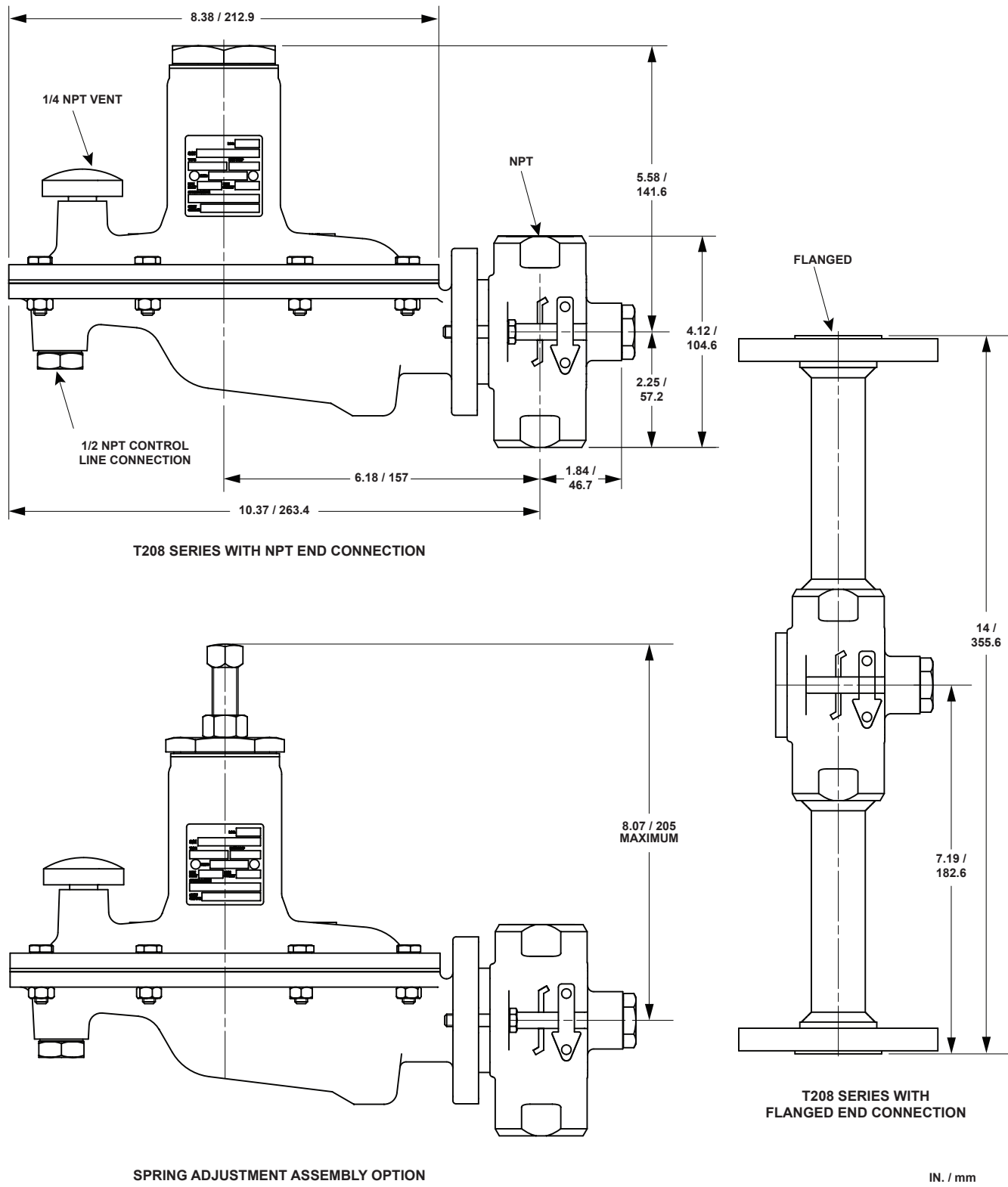

Figure 5. Dimensions

Ordering Information

When ordering, complete the ordering guide on this page. Refer to the Specifications section on page 2. Review the description to the right of each specification and the

information in each referenced table or figure. Specify your choice whenever a selection is offered.

Ordering Guide

Type (Select One)

- T208, Internal pressure registration***
- T208M, External pressure registration***

Body Size (Select One)

- 3/4 in. / DN 20***
- 1 in. / DN 25***

Body Material and End Connection Style (Select One)

Gray Cast Iron

- NPT***

WCC Carbon Steel

- NPT***
- CL150 RF***
- CL300 RF***
- PN 16/25/40 RF*** specify rating _____

CF8M/CF3M Stainless Steel⁽¹⁾

- NPT***
- CL150 RF***
- CL300 RF***
- PN 16/25/40 RF*** specify rating _____

Control Pressure Range (Select One)

- 2.0 to 7.0 in. w.c. / 5 to 17 mbar, Red***
- 3.0 to 13.0 in. w.c. / 7 to 32 mbar, Unpainted***
- 10.0 to 26.0 in. w.c. / 25 to 65 mbar, Yellow***
- 0.9 to 2.5 psig / 62 to 172 mbar, Green***
- 1.3 to 4.5 psig / 90 to 310 bar, Light Blue***
- 3.8 to 7 psig / 0.26 to 0.48 bar, Black***

Trim Material (See Table 2, Select One)

- Standard***
- VV***
- TV***
- TN***
- TK***
- TE***

Adjusting Screw (Select One)

- Internal Flat Circular **(standard)*****
- External Square Head (Available for Green, Light blue and Black springs only. Steel closing cap is automatically supplied in this option)***

Closing Cap Material (Select One)

- Plastic **(standard)** (not available for Green, Light blue and Black springs)***
- Steel **(standard)** for Green, Light blue and Black springs)***
- Stainless steel***

Body Position (See Figure 4, Select One)

- Position 1 **(standard)*****
- Position 2***
- Position 3***
- Position 4***

Spring Case Orientation/Vent Type (Select One)

- Spring Case Down (Type Y602-1) **(standard)*****
- Spring Case Up (Type Y602-11)***

Vent Position (See Figure 4) (Select One)

- Position A **(standard)*****
- Position B***
- Position C***
- Position D***

NACE Standard MR0175-2002 Construction (Select One)

- Yes
- No

Replacement Parts Kit (Optional)

- Yes, send one replacement parts kit to match this order.

1. Pipe nipples and flanges are 316 Stainless steel for flanged body assemblies.

Ordering Guide (continued)

Regulators Quick Order Guide	
***	Readily Available for Shipment
**	Allow Additional Time for Shipment
*	Special Order, Constructed from Non-Stocked Parts. Consult your local Sales Office for Availability.
Availability of the product being ordered is determined by the component with the longest shipping time for the requested construction.	

Specification Worksheet	
Application (Please designate units):	
Specific Use	_____
Line Size	_____
Fluid Type and Specific Gravity	_____
Fluid Temperature	_____
Does the Application Require Overpressure Protection?	
<input type="checkbox"/> Yes <input type="checkbox"/> No If yes, which is preferred:	
<input type="checkbox"/> Relief Valve <input type="checkbox"/> Monitor Regulator <input type="checkbox"/> Shutoff Device	
Is overpressure protection equipment selection assistance desired? _____	
Pressure:	
Maximum Inlet Pressure	_____
Minimum Inlet Pressure	_____
Differential Pressure	_____
Set Pressure	_____
Maximum Flow (Q _{max})	_____
Performance Required:	
Accuracy Requirements?	
Less than or Equal to:	
<input type="checkbox"/> 5% <input type="checkbox"/> 10% <input type="checkbox"/> 20% <input type="checkbox"/> Wide Open	
Other Requirements:	

Industrial Regulators

Emerson Process Management Regulator Technologies, Inc.

USA - Headquarters
McKinney, Texas 75070 USA
Tel: +1 800 558 5853
Outside U.S. +1 972 548 3574

Asia-Pacific
Shanghai 201206, China
Tel: +86 21 2892 9000

Europe
Bologna 40013, Italy
Tel: +39 051 419 0611

Middle East and Africa
Dubai, United Arab Emirates
Tel: +971 4811 8100

Natural Gas Technologies

Emerson Process Management Regulator Technologies, Inc.

USA - Headquarters
McKinney, Texas 75070 USA
Tel: +1 800 558 5853
Outside U.S. +1 972 548 3574

Asia-Pacific
Singapore 128461, Singapore
Tel: +65 6770 8337

Europe
Bologna 40013, Italy
Tel: +39 051 419 0611
Chartres 28008, France
Tel: +33 2 37 33 47 00

Middle East and Africa
Dubai, United Arab Emirates
Tel: +971 4811 8100

TESCOM

Emerson Process Management Tescom Corporation

USA - Headquarters
Elk River, Minnesota 55330-2445, USA
Tels: +1 763 241 3238
+1 800 447 1250

Europe
Selmsdorf 23923, Germany
Tel: +49 38823 31 287

Asia-Pacific
Shanghai 201206, China
Tel: +86 21 2892 9499



The distinctive diamond shape cast into every spring case uniquely identifies the regulator as part of the Fisher® brand and assures you of the highest-quality engineering, durability, performance, and support.

For further information visit www.fisherregulators.com

The Emerson logo is a trademark and service mark of Emerson Electric Co. All other marks are the property of their prospective owners. Fisher is a mark owned by Fisher Controls International LLC, a business of Emerson Process Management.

The contents of this publication are presented for informational purposes only, and while every effort has been made to ensure their accuracy, they are not to be construed as warranties or guarantees, express or implied, regarding the products or services described herein or their use or applicability. We reserve the right to modify or improve the designs or specifications of such products at any time without notice.

Emerson Process Management Regulator Technologies, Inc. does not assume responsibility for the selection, use or maintenance of any product. Responsibility for proper selection, use and maintenance of any Emerson Process Management Regulator Technologies, Inc. product remains solely with the purchaser.