

## Product Data Sheet

PDS 106-302.A01

March, 2011

# Bypass Oxygen Analyzer Package

- Provides the same accurate, reliable measurement of excess oxygen in combustion flue gas as standard in situ, industrial oxygen analyzer
- Inconel steel tubes provide effective resistance to corrosion
- Utilizes no moving parts, air pumps or other components common to sampling systems that require frequent maintenance to remain on-line
- Simple installation provides flexibility to meet various application and space requirements
- Analyzer output ideal for input to automatic combustion trim control

Process heaters found in refineries and other chemical processing industries present high-temperature problems for in situ (located directly within the boiler flue) flue gas oxygen sensors.

Emerson's Rosemount Analytical in situ, zirconium oxide probe-type oxygen analyzer has long been established as the standard of the industry. The Bypass Package has been proven to withstand the high temperatures in process heaters while providing the same advantages offered by the in situ sensor.

The in situ, zirconium oxide oxygen flue gas sensor employs a solid electrolyte sensor inserted directly within the flue, using no moving parts or troublesome sample lines that often experience maintenance problems.

Emerson's Rosemount Analytical oxygen analyzer is a highly reliable flue gas sensor that provides accurate measurements of excess oxygen in combustion flue gas. This measurement can then be incorporated into a combustion trim control program for improving combustion efficiency. The improved efficiency often reduces combustion fuel bills by thousands of dollars, offering returns on the investment in very short time periods.

## APPLICATION

While the atmospheres within process heater flues are relatively clean because the burners are fired in most cases with natural gas or refinery fuel gas, temperatures within the stacks vary from 1200° to 2000°F (650° to 1050°C). Industrial oxygen analyzers typically use an in situ sensor capable of withstanding flue gas temperatures as high as 1300°F (700°C)

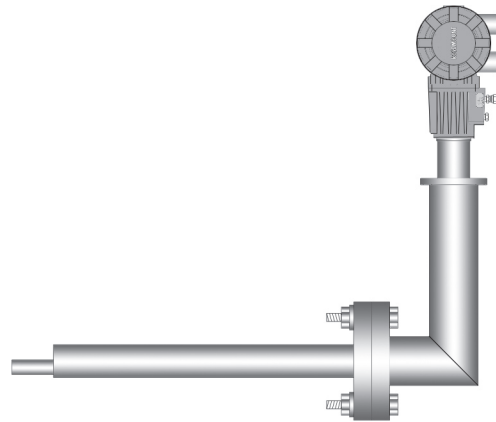

**BYPASS PACKAGE:** The Bypass Oxygen Analyzer Package consists of a 1 inch inconel tube; a 2 inch inconel tube; a Hagan industrial quality oxygen analyzer and an external stainless steel housing. Mounting angles of the external analyzer can vary according to application requirements.

The Bypass Oxygen Analyzer Package was developed to meet process heater application requirements. The Bypass Package employs a standard Emerson industrial-type excess oxygen flue gas analyzer, along with two inconel steel tubes to measure excess oxygen content within the combustion flue gas of the process heater. An inconel tube directs the flue gas to the flue gas analyzer mounted outside the stack. The other inconel tube directs the flue gas back inside the stack. The oxygen analyzer then outputs a fast, highly accurate oxygen measurement ideal for use as an input to closed-loop combustion trim control.

## PRINCIPLES OF OPERATION

The Bypass Package extends the inconel tubes into the flue gas stream. The 1 inch tube directs the flue gas to the oxygen sensor. The 2 inch pipe then directs the flue gas back into the flue.

The oxygen analyzer is mounted outside the stack with the external stainless steel housing. The sensor housing is insulated from the ambient temperature outside the stack at the time of installation. This feature prevents the flue gas from reaching the dew point, eliminating the threat of condensation inside the pipes.

The Bypass Package utilizes a natural ram-air effect to direct the sample gas past the oxygen sensor. Thus, no sample pumps (which require moving parts that often break down), air supplies or aspirators are needed to extract a flue gas sample. This feature eliminates the unreliability and maintenance problems inherent to sampling methods. Applications with heavy particulate loading should utilize a high temperature probe mounting jacket (see PDS 106-303.A01).

**ROSEMOUNT®**  
Analytical

Visit our website at [www.raihome.com](http://www.raihome.com)  
On-line ordering available.

  
**EMERSON™**  
Process Management

The flue gas travels through the inconel pipes by means of natural pressure differential across the inlet and discharge openings. While traveling to the oxygen sensor, the flue gas cools to a temperature suitable to the situ oxygen sensor.

(see PDS 106-300.A01 or IB 106-300NH for operation principles of the Rosemount Analytical in situ oxygen analyzer.)

## INSTALLATION DIMENSIONS

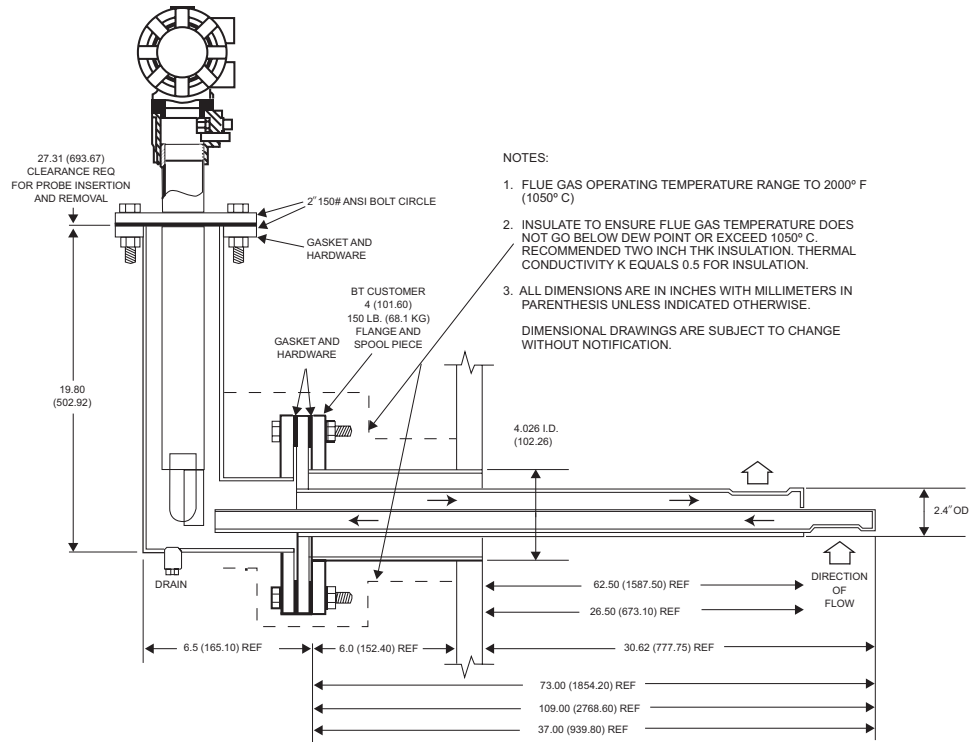

## ORDERING INFORMATION

Part Number	Bypass Packages up to 1050°C (2000°F)
3D39004G01	3 ft. (0.92 m) Bypass Package, (ANSI)
3D39004G02	6 ft. (1.83 m) Bypass Package, (ANSI)
3D39004G03	9 ft. (2.75 m) Bypass Package, (ANSI)
3D39004G04	3 ft. (0.92 m) Bypass Package, (JIS)
3D39004G05	6 ft. (1.83 m) Bypass Package, (JIS)
3D39004G06	9 ft. (2.75 m) Bypass Package, (JIS)
3D39004G07	3 ft. (0.92 m) Bypass Package, (DIN)
3D39004G08	6 ft. (1.83 m) Bypass Package, (DIN)
3D39004G09	9 ft. (2.75 m) Bypass Package, (DIN)

Part Number	Bypass Packages up to 1050°C (2000°F)
3D39004G12	3 ft. Bypass Package, (ANSI) for hazardous area Oxymitter probes
3D39004G13	6 ft. Bypass Package, (ANSI) for hazardous area Oxymitter probes
3D39004G14	9 ft. Bypass Package, (ANSI) for hazardous area Oxymitter probes
3D39004G15	3 ft. Bypass Package, (DIN) for hazardous area Oxymitter probes
3D39004G16	6 ft. Bypass Package, (DIN) for hazardous area Oxymitter probes
3D39004G17	9 ft. Bypass Package, (DIN) for hazardous area Oxymitter probes
3D39004G18	3 ft. Bypass Package, (JIS) for hazardous area Oxymitter probes
3D39004G19	6 ft. Bypass Package, (JIS) for hazardous area Oxymitter probes
3D39004G20	9 ft. Bypass Package, (JIS) for hazardous area Oxymitter probes

The contents of this publication are presented for informational purposes only, and while every effort has been made to ensure their accuracy, they are not to be construed as warranties or guarantees, express or implied, regarding the products or services described herein or their use or applicability. All sales are governed by our terms and conditions, which are available on request. We reserve the right to modify or improve the designs or specifications of our products at any time without notice.

To find the local Rosemount Analytical specialist near you, go to:  
[http://www.emersonprocess.com/raihome/sp/contact\\_us.asp](http://www.emersonprocess.com/raihome/sp/contact_us.asp)



**EMERSON**  
 Process Management