

# Rosemount 570

## Natural Gas Chromatograph

The Rosemount 570 Gas Chromatographs offer the broadest range of analysis options available today in a field-mounted gas chromatograph. Whether it is heating value measurement, trace contaminant monitoring, pipeline integrity, or product quality/process control, the 570 is flexible enough to meet your analysis needs. The proven technology and software of the 570 series offers superior reliability and precision, lower installation and operating costs, greater application flexibility, and unmatched measurement performance.

Proven solutions for fiscal metering or gas quality measurements.

## Available Models

### Rosemount 570/571 BTU/CV Gas Chromatograph

- Custody transfer and gas quality analysis
- Compositional analysis of pipeline gas (CH<sub>4</sub> to C<sub>6</sub>+, N<sub>2</sub> and CO<sub>2</sub>)
- Calculates heating value, relative density, compressibility, Wobbe index and more - all standard
- ±0.025 % CV repeatability over complete temperature range
- ±0.0125 % CV when installed in a temperature controlled environment

### Rosemount 590/591 Dual Oven Gas Chromatograph

- Extended compositional analysis of rich pipeline quality gas for better accountability of the heavier components
- Supports a more complete AGA8 calculation
- Dual detectors with 2 ppm minimum detectability on a C<sub>9</sub>+ peak
- ±0.05 % CV repeatability over complete temperature range
- Optional hydrocarbon dew point calculation software
- Optional C<sub>6</sub>+ measurement with H<sub>2</sub>S

### Rosemount 570 On-Line Gas Chromatograph

- For most trace and % level gas processing, LNG, and pipeline product applications up to 185 °F (85 °C)
- Isothermal analysis with one or two micro-thermal conductivity detector/heat-sink ovens
- Liquid and gas analysis in a single unit
- Optional heated sample conditioning oven up to 185 °F (85 °C)



Rosemount 570 Natural Gas Chromatograph

## Features

### Unmatched Measurement Performance

- Highest stated precision (±0.25 BTU/1000 for broad ambient temperature C<sub>6</sub>+ analysis)
- Wide dynamic range from percent to trace level components
- Reliable performance over broad ambient temperatures (-18 °C to 55 °C/0 °F to 131 °F)

### Lower Operation and Maintenance Costs

- No shelter or instrument air required
- Low helium and power consumption
- Longest chromatograph valve and column warranties available

### Easy to Use

- Ethernet and Modbus connectivity
- MON2000™ software setup and diagnostics
- Identical setup and operation for all models – no additional training

## Applications

### Standard Natural Gas Applications

We have made our most popular energy and gas quality applications standard. Applications may vary by components of interest, analysis time, reduced hardware (economics), or improved precision. If our standard application solutions don't fit your unique needs, we can customize solutions for many application requirements. Contact your account representative for further information.

### Energy Measurement (to C6+ and C9+)

The 570 series offers applications for energy measurement from C6+ hydrocarbon ranges to C9+ hydrocarbon ranges. Choose from the latest ISO 6976, GPA 2172, AGA 8 calculation methods with GPA 2145 physical constants.

Standard Measurement Ranges		Rosemount	Rosemount
		570/571	590/591
		<b>C6+</b>	<b>C9+</b>
Methane	65 to 100 mole %	}	}
Ethane	0 to 20 mole %		
Propane	0 to 10 mole %		
N-Butane	0 to 5 mole %		
Iso-Butane	0 to 5 mole %		
N-Pentane	0 to 1 mole %		
Iso-Pentane	0 to 1 mole %		
Neo-Pentane	0 to 1 mole %		
Nitrogen	0 to 20 mole %		
Carbon Dioxide	0 to 20 mole %		
Hexanes	0 to 0.7 mole %		
Heptanes	0 to 1 mole %		
Octanes	0 to 0.5 Mole %		
Nonane <sup>+</sup>	0 to 0.5 mole %		

### Gas Quality Analysis

Natural gas contaminants reduce pipeline integrity over time. Most contaminants can be easily measured in the Rosemount 570 for on-line quality assurance. Contaminant monitoring can be combined with energy measurements for complete custody transfer analysis. To the extent possible, these combined applications utilize independent chromatograph valves, detectors and columns, for each primary measurement. This technique offers greater reliability, increased speed, and easier troubleshooting. This approach also makes field upgrades and re-applications in the 570 easy, by minimizing internal piping changes.

### Hydrocarbon Dew Point Calculation

Hydrocarbon dew point analysis is proving to be an important tool for identifying unaccounted for or lost BTU in the pipeline due to condensation.

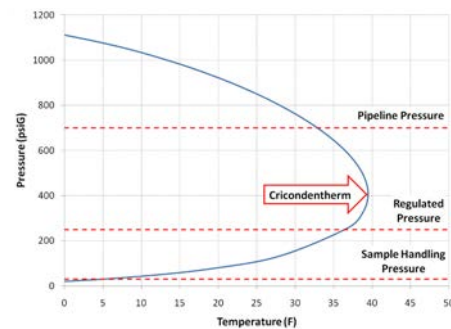

Calculations of the Hydrocarbon Dew Point are made using PR or RKS equations-of-state and latest physical property data.

### Custom Applications

If our standard applications do not fit your needs, the Rosemount 570 can be customized to meet many measurement requirements. Simply submit a completed application data sheet found at the end of this data sheet with your request, or ask our application engineers for assistance.

**Table 1 - Standard Rosemount Natural Gas Chromatographs Applications and Repeatability**

Application Code	Application Name	Components Measured	Analysis Time	% Repeatability @ Controlled Temperature	% Repeatability Over 0–130 °F
570	Standard BTU/CV	C1 to C6, CO <sub>2</sub> , N <sub>2</sub>	4 min	±0.0125	±0.025
570C7	Standard C7+ BTU/CV	C1 to C7+, CO <sub>2</sub> , N <sub>2</sub>	10–12 min	±0.025	±0.05
	Gas Quality (H <sub>2</sub> S)	Trace H <sub>2</sub> S (3–30 ppm)	90 sec	±2 ppm	±3 ppm
570F8	Landfill Gas BTU/CV	C1, N <sub>2</sub> , CO <sub>2</sub> , O <sub>2</sub>	8 min	±0.1	±0.2
5703	Landfill Gas (mole-sieve)	C1, N <sub>2</sub> , CO <sub>2</sub> , O <sub>2</sub> →	3 min	±0.1	±0.2
570PS	Std C6+ with % H <sub>2</sub> S	C1, C6+, CO <sub>2</sub> , N <sub>2</sub> , H <sub>2</sub> S (%)	10 min	±0.05	±0.1
570OX	Std C6+ with % Oxygen	C1, C6+, CO <sub>2</sub> , N <sub>2</sub> , O <sub>2</sub>	10 min	±0.05	±0.1
570HH	Std C6+ with Helium/Hydrogen	C1, C6+, CO <sub>2</sub> , N <sub>2</sub> , He/H <sub>2</sub>	5 min	±0.05	±0.1
590TS	C6+ with ppm H <sub>2</sub> S	C1, C6+, CO <sub>2</sub> , N <sub>2</sub> , H <sub>2</sub> S (ppm)	7 min	±0.0125/±2 ppm	±0.025/±3 ppm
590	Std C9+ →	C1, C9+, CO <sub>2</sub> , N <sub>2</sub>	5 min	±0.025	±0.05
590HC	Std C9+ and Hydrocarbon Dewpoint	C1, C9+, CO <sub>2</sub> , N <sub>2</sub>	5 min	±0.025	±0.05

## Engineered Difference

- Extreme ambient temperature operation minimizes installation and utility requirements.
- Easy-to-use MON2000™ software for advanced diagnostics and simplified troubleshooting
- Rosemount diaphragm valves offer a lifetime warranty
- High-sensitivity thermal conductivity detectors can often replace the need for more complex detectors
- Broad application scope with single or dual detector capability
- Micro-packed columns that are made to last

## Custom-Engineered Sample Systems

A gas chromatograph is only as good as the quality of the sample it measures. Every sample system for Rosemount Gas Chromatographs is custom-engineered for the specific requirements of the application.

Common features include:

- Heated and open panel designs
- All components rated for the area classification
- Automatic calibration/validation available as an option
- Variety of sample probes to extract a reliable and stable sample from the process

## Lower Installation and Maintenance Cost

Rosemount gas chromatographs offer the lowest cost of ownership in the industry. Most process measurements can be made at or near the sample point, greatly reducing the overall lifetime cost of the measurement. Expenses such as shelters, air conditioning, heating, long/heated sample lines can be minimized or completely eliminated in most applications. Furthermore, Rosemount natural gas chromatographs are designed to operate unattended for long periods of time without adjustment. When adjustments are required, all components are easily accessible and can be performed in the field in minutes with standard tools.

## Environmental Chamber Testing

Rosemount provides the most thorough gas chromatograph testing in the world. Each 570 must operate to specification in our walk-in environmental test chambers cycling between 0 °F and 130 °F for 24 hours minimum. This is all part of our commitment to manufacturing gas chromatographs that are capable of providing reliable measurements in the field.

Figure 1 - Variable Temperature Testing

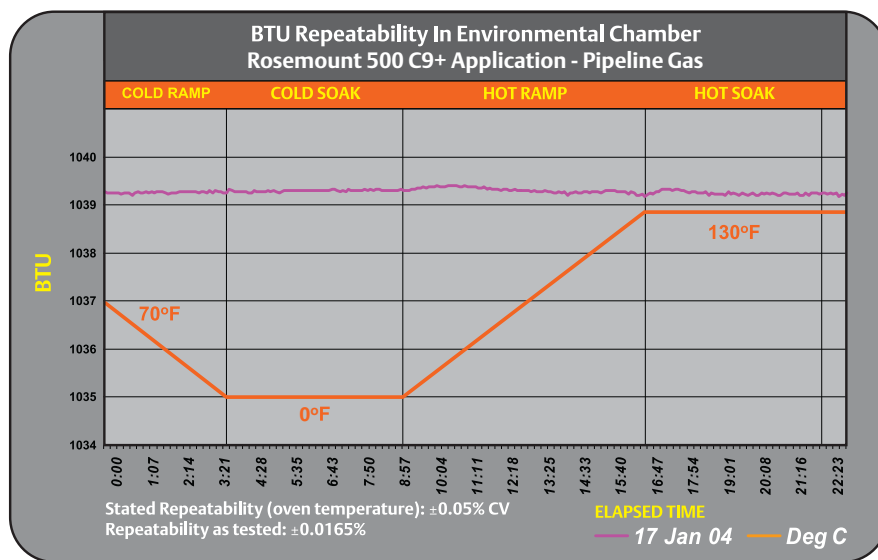

*To ensure installed performance, every Rosemount 570 gas chromatograph is tested for superior measurement stability in extreme climates before it ships.*

## Internal Components

### Gas Chromatograph Valves

The Rosemount 570 offers six and ten-port diaphragm/piston gas chromatograph valves that are the heart of our superior gas chromatograph reliability. These pneumatic valves are guaranteed for the life of the gas chromatograph and specified to operate over five million times between service. By minimizing internal movement (1/1,000 inch) of the pistons, which never come in contact with the sample, abrasive mechanical wear is virtually eliminated. This unique double-diaphragm design removes the need for all springs, o-rings, or lubrication. Valve service is performed by replacing a cost-effective diaphragm set, normally completed in less than ten minutes.



*The diaphragm valve used in the Rosemount 570 is so reliable, it comes with a lifetime warranty.*

### Airless (Heat Sink) Oven

The heat sink oven in the Rosemount 570 integrates the detector, columns, and analytical valves in a single, temperature-controlled assembly. This unique design enables the analyzer to be mounted in the field without the need for elaborate weather protection or instrument air. To ensure performance to specifications, the majority of our gas chromatographs are tested for repeatability in an environmental chamber prior to shipment, where they are cycled from 0–130 °F for 24 hours. Customers are welcome to request testing in our environmental chamber free of charge for every gas chromatograph that is purchased.

### High-sensitivity Thermal Conductivity Detector (TCD)

The TCD thermistor is the detector of choice for most applications due to its universal response to all compounds. The Rosemount thermistor TCD is able to go well beyond the normal measuring ranges seen in other designs by being able to do many applications with low parts-per-million measurement requirements. This greatly simplifies the gas chromatograph design when a simple and rugged TCD can be used rather than a more complex flame ionization detector (FID).

- TCD detector is sensitive down to 3 ppm
- Dual TCD/TCD configurations available

### Micro-packed Columns

Rosemount micro-packed columns offer a superior combination of features found in both capillary and conventional packed columns — speed, sharp peak resolution, and low carrier gas consumption. In addition, this unique design provides for greatly extended column life — as well as the longest warranty available on the market (five years on the standard C6+ natural gas set).

### Packaging Accessories

We offer standard and custom gas chromatograph packaging accessories to meet your installation requirements.

#### Gas Chromatograph System Enclosures

- Complete range of gas chromatograph enclosure solutions ranging from simple sun-shields and cabinets to skids, systems and shelters
- API 14.1 compliant solutions with heating of sample lines and calibration gas

#### Standard Auxiliary Equipment

- Sample probes/pressure regulators/filters for a wide range of sample handling requirements
- Carrier gas systems with dual manifold regulators for uninterrupted operation
- Calibration gasses and heating blankets

## Analyzer Networking and Data Communications

The Rosemount Natural Gas Chromatographs can be configured in a number of networking and data communication schemes to meet process communication requirements. Options include Ethernet networks as well as multi-drop RS-485 networks. It is even possible to set up automatic polling for data collection over phone lines if desired.

Data communication options to the plant control system include simple analog and discrete signals as well as Modbus serial links. To preserve the integrity of the analysis data, all 570 GCs are capable of storing up to 35 days of analysis or calibration data in the event of loss of communication to the plant control system.

All Rosemount Natural Gas Chromatographs are designed to operate unattended. Occasionally, adjustments to the analyzers' analytical method or a review of alarms may be needed. Using our exclusive MON2000 software loaded on either a PC or laptop running Windows®, you'll have complete control of your natural gas chromatographs – either locally or remotely

### Rosemount 2350A Gas Chromatograph Controller

The main electronics for the Rosemount 570 is mounted in a separate explosion-proof enclosure with integral keypad and display. An optional 19" rack-mount version is available. For additional features and specification, please reference Rosemount 2350A gas chromatograph controller product data sheet.



Rosemount 2350A Gas Chromatograph Controller

### Networking Flexibility

Whether you want to network process gas chromatographs throughout the plant or simply link a single gas chromatograph to the DCS, the Rosemount 570 can be configured to handle most any scenario:

- Choice of Ethernet or RS-485 networks
- Use the same network to connect Rosemount 770, 570, and 1000 gas chromatographs
- Able to connect multiple PC workstations using MON2000
- Connectivity to plant control systems using industry standard protocols such as Modbus and OPC

Figure 2 - Gas Chromatograph Open Network Architecture

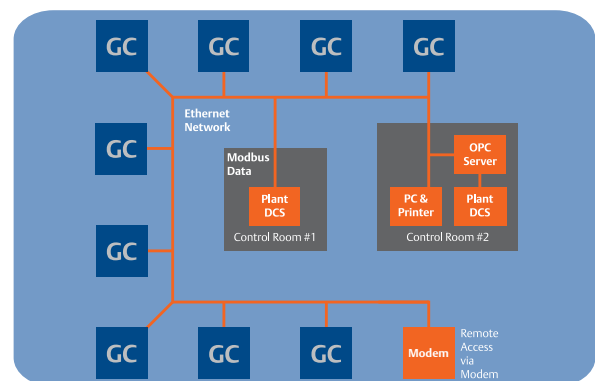

Using Ethernet access, analyzers transmit directly to the plant's digital control system (including DeltaV®) quickly and securely through industry standard Modbus or the new OPC protocol.

### Secure Modbus Connectivity

For online gas chromatographs, Modbus continues to be the preferred choice to connect to a gas chromatograph network. Our Modbus design avoids the use of central interface cards or computers that can act as a single-point of failure in the Modbus link. Instead, the flow computer or SCADA system can "talk" directly to each gas chromatograph to gather the data needed. Furthermore, the register and coil addresses can be easily customized to meet the specific data structure of the flow computer or SCADA system. There is also a program built into the MON2000 workstation to test the Modbus link if troubleshooting is needed.

## Specifications

Please consult Rosemount if your requirements are outside the specifications listed below. Improved performance, other products and material offerings may be available depending on the application.

### Construction

**Environmental:** -18° to 55 °C (0° to 130 °F)

**Dimensions (without sample system):**

164 cm H x 51 cm W x 53.5 cm D (64.5" H x 20" W x 21" D)

**Mounting:** Free-standing (standard); wall-mount (optional)

**Approximate Weight (without sample system):**

Approximately 36 kg (79 lbs.)

**Area Safety Certification Options (hardware dependent):**

**Standard:** Designed to meet NEC Class I, Div. 1, Groups C,D  
(Group B with optional air purge)

**Optional:** CSA NRTL/C Certified :  
Class I, Div. 1, Groups C, D, T3B

### Performance Capabilities

**Oven:** Airless heat sink, maximum 85 °C (185 °F)

**Valves:** Six-port and ten-port diaphragm chromatograph valves. Other types of valves may be used depending on the application such as liquid injection and rotary valves

**Carrier Gas:** Application dependent. Typically zero-grade helium, nitrogen, or hydrogen at 90 psig

**Detector:** Thermal conductivity detector (TCD); up to two depending on application. Flame photometric detector (FPD) available (see FPD Module data sheet)

**Gating Options:** Fixed-time, slope and automatic gating of peaks

**Streams:** Up to 12 streams (including calibration stream)

### Electronics

**Power:** 115 VAC ±15 %, 220 VAC ±15 %, 50/60 HZ

**Typical Power Consumption:** 100 watts running, 350 watts startup

**Chromatograms Control Electronics:** Mounted with the gas chromatograph in explosion-proof housing or remotely in 19" rack-mounting

### Communications (Standard)

**Analog Inputs:** Four inputs filtered with transient protection (note that the four inputs will be used by the second TCD)

**Analog Outputs:** Two outputs standard (up to ten optional), 4–20 mA, non-isolated

**Serial Communication Ports:** Three serial ports standard with option for a total of eight. Depending on the port, choice of RS-232, RS-422 and RS-485 is available as well as the Modbus protocol

**Digital Inputs (optional):** One gas chromatograph alarm and five user assignable inputs, optically isolated with transient protection

**Digital Outputs (optional):** Five digital outputs can be used for alarms, optically isolated with transient protection

**Parallel Printer Port (optional):** One parallel port available for printed reports

**Internal Modem (optional):** Field-configurable; 300 to 19.2 k baud

**Transient Protection:** C.E. tested and certified to the highest levels (3 and 4) of the European IEC 801 STD

# Recommended Installation

The drawings below represent the minimum recommended installation guidelines for the Rosemount 570 natural gas chromatographs. Please consult Rosemount for detailed installation recommendation of your application.

## Rosemount 570 Single Oven Dimensional Drawing

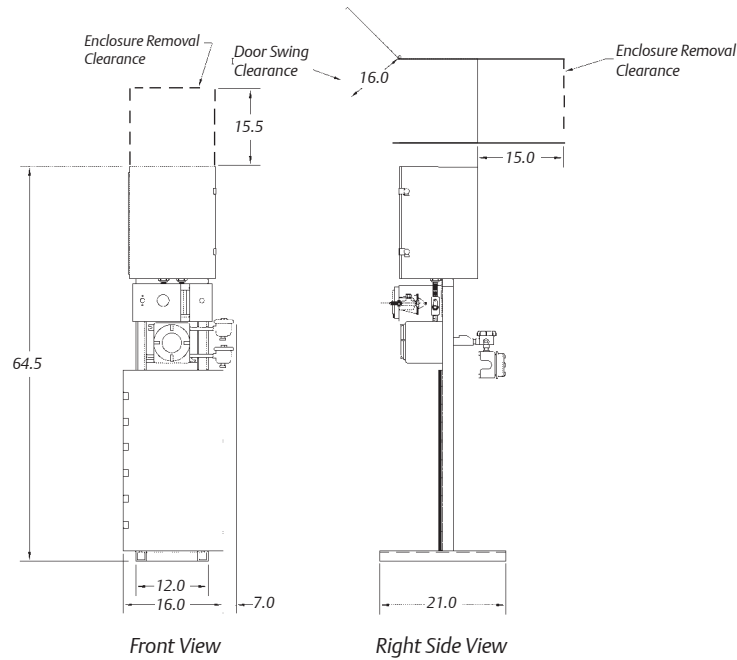

## Rosemount 570 Dual Oven Dimensional Drawing

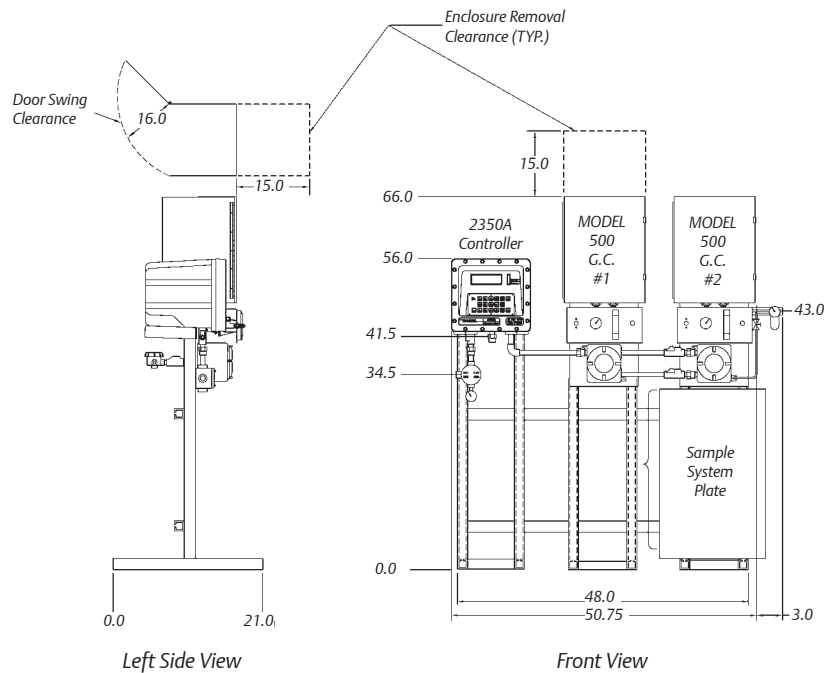

## MON2000™ Software

The Rosemount 570 natural gas chromatograph is designed to operate unattended. If, however, adjustments are needed, our exclusive MON2000™ software allows complete control of your gas chromatographs – either locally or remotely.

From within MON2000, a user can:

- Review and modify analytical settings
- Upload and display multiple chromatograms on the screen for comparison
- Upload and trend any of the measured results
- Export data for use in other third-party applications
- Overlay multiple chromatograms for troubleshooting and calibration
- Check original calibration against last calibration

The MON2000 Software is Windows®-based software designed to make analyzer configuration, maintenance, and data collection easy. With intuitive dropdown menus and fill-in-the-blank tables, even new users can quickly navigate through the software.

The MON2000 software can display both current and multiple archived chromatograms on the screen, streamlining the time needed to perform routine analyzer maintenance.

MON2000 also has a number of tools built in that help users manage their analyzers such as:

- Automatic recording of alarms in a log file
- Event logs that provide a continuous record of all operator changes with time and user name stored
- Maintenance log scratch pad for keeping track of maintenance or testing done

Data collected from the gas chromatographs can be stored and displayed in a wide range of options, such as trend lines on the screen and logs automatically documenting all changes made to the gas chromatograph. Data can also be exported in formats compatible with most third-party Windows® applications.

Figure 3 - Typical MON2000 Workstation Screen



Comparing multiple chromatograms and zooming into specific sections is easy with the point-and-click design of MON2000.

### EmersonProcess.com/GasAnalysis

 YouTube.com/user/RosemountAnalytical

 Analyticexpert.com

 Twitter.com/Rosemount\_News

 Facebook.com/Rosemount

©2015 Emerson Process Management. All rights reserved.

The Emerson logo is a trademark and service mark of Emerson Electric Co. All other marks are the property of their respective owners.

The contents of this publication are presented for information purposes only, and while effort has been made to ensure their accuracy, they are not to be construed as warranties or guarantees, express or implied, regarding the products or services described herein or their use or applicability. All sales are governed by our terms and conditions, which are available on request. We reserve the right to modify or improve the designs or specifications of our products at any time without notice.

**Emerson Process Management**  
Rosemount Analytical  
10241 West Little York, Suite 200  
Houston, Texas 77040  
USA  
Toll Free + 866 422 3683  
T + 713 396 8880  
F + 713 466 8175  
[GC.CSC@Emerson.com](mailto:GC.CSC@Emerson.com)