

# Triple Junction pH/ORP Sensor

- SMART enabled 
- RETRACTABLE VERSION allows safe removal and replacement under pressure without process shutdown.
- LONG-LIFE, TRIPLE JUNCTION REFERENCE ELECTRODE provides longer service life in applications where poisoning ions are present.
- DISPOSABLE TEFZEL<sup>1</sup> AND TITANIUM DESIGN provides maximum chemical resistance and economic advantage where minimal troubleshooting and maintenance downtime are of prime importance.
- PLATINUM ORP electrode.



## FEATURES AND APPLICATIONS

**The Triple-junction 385+ is now offered with SMART capabilities.** SMART option becomes enabled when used with the 1056, 1057, 1066 and 56 Analyzer and on 6081P wireless transmitter. The pH-loop capabilities include auto-recognition of the SMART sensor, automatic upload of calibration data and associated time stamp, historical recording of pH diagnostics (slope, offset, reference impedance, glass impedance). This trending data allows technicians to predict frequency of maintenance and estimate sensor life for a particular process condition. Additional SMART features include factory calibration, resetting SMART sensor calibration data with user menus without power cycling, and manufacturing information.

The Rosemount 385+ Sensor is designed to provide advanced sensor diagnostics available with the 54e, 1055, 1056, 1057, or 56 pH/ORP Analyzer, or Models 81, 3081, 4081, 5081, 6081 or 1066 Transmitter. (Please refer to the instrument's product data sheet for complete information.) These advanced sensor diagnostics provide preventative maintenance by notifying the operator to replace an aged sensor or clean a fouled sensor for continuous optimum performance.

The 385+ Sensor measures the pH or ORP (Oxidation Reduction Potential) of aqueous solutions in pipelines, open tanks, or ponds. It is suitable for applications where a low cost, industrial, disposable sensor is required. The combination electrode features a peripheral ceramic junction. The triple junction reference cell provides longer life in processes containing sugar, ammonia, chlorides, sulfides or other poisoning ions. The 385+ body is constructed of molded, chemically resistant Tefzel in two standard body versions.

The retraction version is housed in a titanium tube, with a plug-in style surface mount preamplifier in a weatherproof junction box. It is designed for use with a standard 1-1/2 in. ball valve assembly for process mounting where a separate sample stream is difficult or impossible to provide. The entire installation process is accomplished without line depressurization and minimal process fluid loss. Following sensor removal from the ball valve, maintenance and replacement is easy.

The insertion/submersion version has two body configurations: 25 ft (7.6 m) integral cable and preamplifier; 15 ft (4.5m) integral cable for use with remote preamplifier.

<sup>1</sup> Tefzel is a registered trademark of E.I. du Pont de Nemours & Company

## PERFORMANCE AND PHYSICAL SPECIFICATIONS

**Sensor Type:** Triple-junction 385+ AccuGlass™<sup>1</sup>

**Range:** 0-14 pH

Percent Linearity Over pH Range		
	Option 10	Option 11
0-2 pH	94%	94%
2-12 pH	99%	97%
12-13 pH	97%	98%
13-14 pH	92%	98%

**ORP:** ±1500 mV

**Maximum Process Pressure and Temperature:**  
790 KPa (abs) (100 psig) at 100°C (212°F)

<sup>1</sup> Trademark of Rosemount Analytical.

<sup>2</sup> Registered trademark of E.I. du Pont de Nemours & Company.

**Maximum Pressure at Retraction or Insertion**

**(ball valve version):** 542 KPa (abs) (64 psig)

**Temperature Compensation:** (pH only) 0 to 100°C (32 to 212°F)

**Wetted Materials:** Tefzel, titanium, EPDM, 316 SS and Teflon<sup>2</sup> (Code 02), Viton<sup>2</sup>, glass, ceramic and (ORP only) platinum.

**Cable:** P/N 9200273 (Unprepped) or P/N 23646-01 (Prepped)

**Process Connections:** 1-1/2 in. with ball valve;  
1 in. without ball valve

**Weight/Shipping Weight:**

Submersion/insertion: 1.6 lb/2.8 lb (0.7Kg /1.25 Kg)

Retraction: 6 lb/11 lb (2.7 Kg/5.0 Kg)

Ball Valve: 5 lb/10 lb (2.25 Kg/4.5 Kg)

## INSTALLATION AND ACCESSORIES SPECIFICATIONS

### TYPICAL MOUNTING CONFIGURATIONS FOR THE 385+

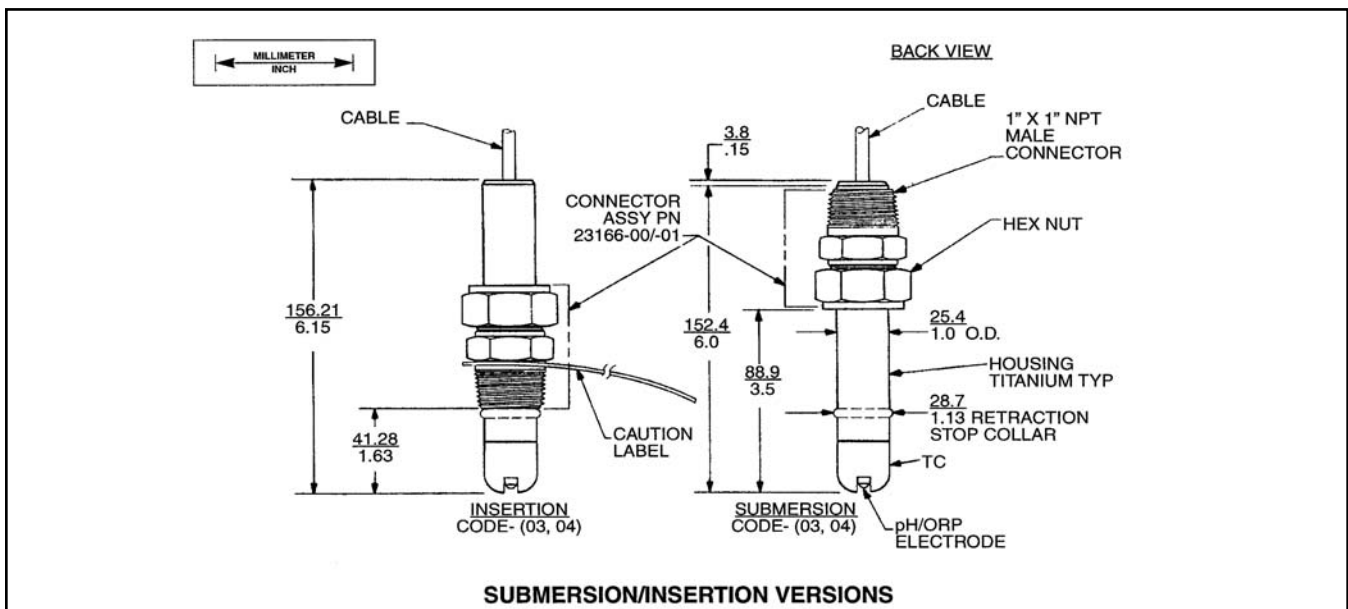
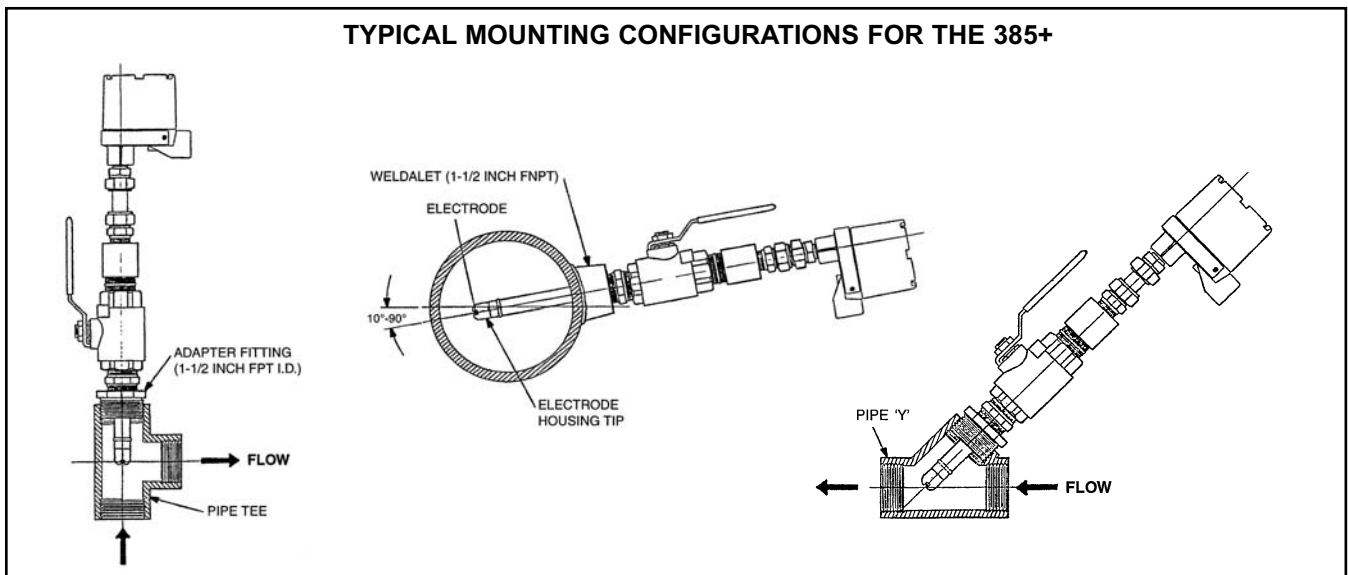

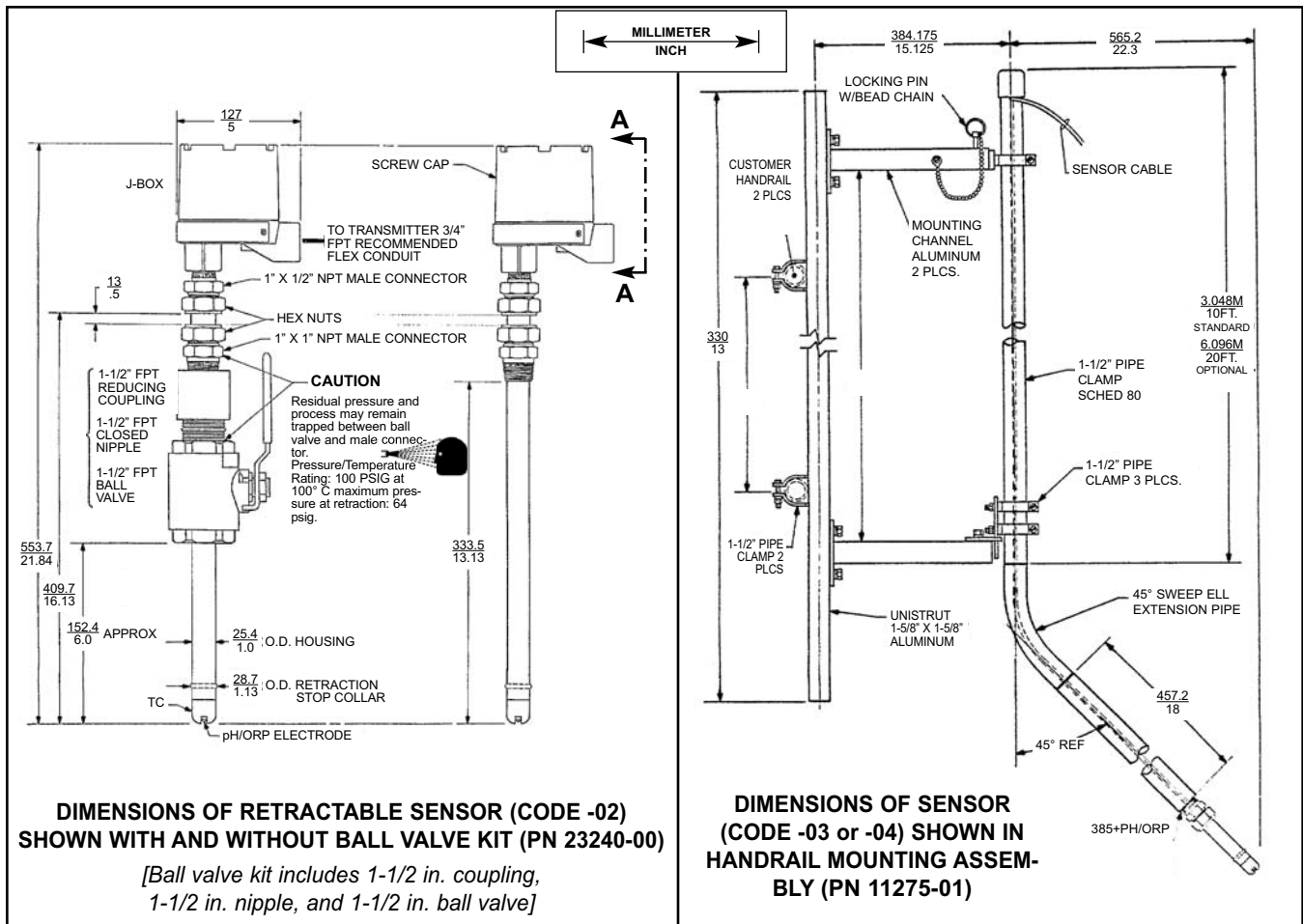

**FOR FIRST TIME 385+ INSERTION/SUBMERSION INSTALLATIONS, USE THE FOLLOWING GUIDE:**

**1. Process Connector Accessories (required for all first time installations of code -03 and -04 sensors)**

- Choose one: PN 23166-00, 316 SST, 1 in. x 1 in. NPT process connector
- PN 23166-01, Titanium, 1 in. x 1 in. NPT process connector
- PN 9510066, Nylon, 1 in. x 1 in. NPT process connector

**2. Mounting Accessories (optional)**

- Choose one: PN 915240-03, PVC flow through tee, 3/4 in. NPT process connection
- PN 915240-04, PVC flow through tee, 1 in. NPT process connection
- PN 915240-05, PVC flow through tee, 1 1/2 in. NPT process connection
- PN 11275-01, Handrail mounting assembly

**3. Remote Junction Boxes (optional, recommended for sensor-to-analyzer distances of more than 15 ft)**

- Choose one: PN 23555-00, includes preamplifier for Models 54, 56, 1056, 1057, 1066, 81, 3081, 4081
- PN 23550-00, for cable extension (code -02 or -03 only)

**4. Extension cables (used with remote junction boxes)**

- Choose one: PN 23646-01, 11 conductor, shielded, prepped
- PN 9200273, 11 conductor, shielded, unprepped

**FOR FIRST TIME 385+ RETRACTABLE INSTALLATIONS, USE THE FOLLOWING GUIDE:**

**1. Retractable Mounting**

- Choose one: PN 23240-00, 1 1/2 in. ball valve assembly, 316 SST
- PN 23765-00, 1 1/4 in. ball valve assembly, 316 SST

**2. Extension cables**

- Choose one: PN 23646-01, 11 conductor, shielded, prepped
- PN 9200273, 11 conductor, shielded, unprepped

## ORDERING INFORMATION

**The 385+ pH/ORP Sensor:** Standard features include a Tefzel sensor body with a triple junction gel filled reference electrode and automatic temperature compensator housed in a titanium tube. The retractable version comes with a weatherproof junction box, a process connector, and preamplifier. The insertion/submersion version has two optional body configurations: integral SMART preamplifier (-03) option. The SMART is standard preamp option. It is offered with 25 ft (7.6 m) integral cable. A conventional 385+ is offered with 15 ft (4.5 m) integral cable for use with remote preamplifier if the distance to the instrument exceeds 15ft. The 385+ is designed to be used with the Models 54e, 1055, 1056, 1057, or 1066 pH/ORP Analyzer, or Models 56, 81, 3081, 4081, 5081, 6081 or Xmt pH/ORP Transmitter.

385+ pH/ORP SENSOR	
Code	Body Configuration (Required Selection)
02	Retractable with sensor head junction box, preamplifier, and process connector
03*	Insertion/Submersion with Integral SMART Preamplifier (Standard option) and 25 ft (7.6 m) cable
04*	Insertion/Submersion for use with Remote Preamplifier and 15 ft (4.5 m) cable

Code	Combination Electrode (Required Selection)
10	GPLR, General Purpose Low Resistivity (0-13 pH)
11	High (0-14 pH)
12	ORP (Platinum)

385+	-03	-10	EXAMPLE
------	-----	-----	---------

### NOTES:

**OPTION-02** recommended interconnecting cable from sensor to transmitter is Rosemount Analytical P/N 23646-01 (prepped) or P/N 9200273 (unprepped). Specify length.

\* **OPTION-03, 04** require a 1 x 1 in. NPT process connector. Recommended PN's 23166-00 or 23166-01.

## ACCESSORIES

ACCESSORIES	DESCRIPTION
9210012	Buffer solution, 4.01 pH, 16 oz
9210013	Buffer solution, 6.86 pH, 16 oz
9210014	Buffer solution, 9.18 pH, 16 oz
R508-80Z	ORP solution, 460 mV $\pm$ 10 at 20°C
9550167	EPDM O-ring for Process Connector (PN 23166-00 or 23166-01)
12707-00	Jet Spray Cleaner for submersion service



*The right people,  
the right answers,  
right now.*

ROSEMOUNT ANALYTICAL  
CUSTOMER SUPPORT CENTER  
1-800-854-8257



ON-LINE ORDERING NOW AVAILABLE ON OUR WEB SITE  
<http://www.raihome.com>

*Specifications subject to change without notice.*



Credit Cards for U.S. Purchases Only.



### Emerson Process Management

2400 Barranca Parkway  
Irvine, CA 92606 USA  
Tel: (949) 757-8500  
Fax: (949) 474-7250

<http://www.raihome.com>

© Rosemount Analytical Inc. 2012

