

Rosemount 370XA

Natural Gas Chromatograph

The Rosemount 370XA natural gas chromatograph, the latest analyzer to join the XA Series of Emerson gas chromatographs, is designed to provide greater ease of use and increased measurement performance for your C6+ BTU/CV analysis.

A unique feature of the 370XA is its *Maintainable Module™* technology, which allows you to easily replace the GC module in the field in under two hours, including warm-up time and purge, greatly reducing downtime and overall operating costs.

Incorporating an operating method similar to previous gas chromatographs, the 370XA gives you the option of using hydrogen carrier gas or air/nitrogen actuation gas instead of helium.

The local operator interface (LOI), a standard feature in the 370XA, is a full color VGA display with an alpha-numeric keypad that allows operators to perform common tasks without having to connect to a computer. The LOI has built in tutorials to guide even the most inexperienced operator through step-by-step instructions on how to safely operate and maintain the GC, therefore reducing the need for specialized technicians.

Features

Designed for Custody Metering of Natural Gas

- Four-minute C6+ BTU/CV analysis
- $\pm 0.0125\%$ repeatability of heating value (± 0.125 BTU/1000 BTU) in controlled environments
- $\pm 0.025\%$ repeatability of heating value (± 0.25 BTU/1000 BTU) over extended temperature range of $-20\text{ }^{\circ}\text{C}$ to $60\text{ }^{\circ}\text{C}$ ($-4\text{ }^{\circ}\text{F}$ to $140\text{ }^{\circ}\text{F}$)
- Latest GPA 2145, GPA 2172, and AGA 8 calculations
- Latest ISO 6976 calculations
- Analysis results storage in excess of the latest API 21.1 requirements



Rosemount 370XA Natural Gas Chromatograph.

Simplified Functionality and Ease of Use

Full color LOI with built-in software assistants to guide the operator through common tasks, such as:

- Module replacement
- Change calibration gas
- Auto-valve timing

Reduced Installation Costs

- 24 VDC power with less than 55 Watts startup and < 25 Watts (steady state) nominal power
- Pole (standard) and wall mount options
- No shelter required for most environments, optional enclosure available for extreme environments

Lower Operational Costs

- Reduced carrier gas usage
- Automatic validation routine reduces calibration gas usage
- *Maintainable Module™* replacement is quick and easy
- Optional utility gases: H_2 , He, N_2

The 370XA is designed for the continuous online analysis of natural gas. The analysis uses configuration of three six-port valves with four separation columns to measure the common components found in natural gas.

Table 1 - C6+ Standard Measurement Ranges

Component	Measurement Range
Methane	65 to 100 mole %
Ethane	0 to 20 mole %
Propane	0 to 10 mole %
N-Butane	0 to 5 mole %
Iso-Butane	0 to 5 mole %
N-Pentane	0 to 1 mole %
Iso-Pentane	0 to 1 mole %
Neo-Pentane	0 to 1 mole %
Nitrogen	0 to 20 mole %
Carbon Dioxide	0 to 20 mole %
C6+	0 to 1 mole %

Note: The Hydrogen Sulfide and Water limit in a sample is 0.02 mole %

Applications

Natural Gas Custody Transfer

Rosemount gas chromatographs are synonymous with natural gas custody transfer and known for improving gas measurement analysis and reducing lost-and-unaccounted-for (LAUF) gas.

The 370XA can perform ISO or GPA/AGA based physical property calculations and store the analysis results in non-volatile memory for a period of at least 85 days. The stored data can be easily retrieved using MON2020™ or via Modbus communication. Industry standard SIM_2251 Modbus maps are used as the default serial communication protocol; however, the 370XA can be customized to accommodate other requirements as needed.

Designed to easily replace other less accurate C6+ gas chromatographs currently installed in the network, the 370XA does not require configuration changes to the SCADA system or Flow Computer.

Production Gas Measurement

Analyzing production gas in the gathering network has traditionally been done with manual or automatic samplers. However, the ongoing costs of collecting and analyzing these samples and the time delay between collecting the sample and receiving the results is leading many producers to look at installing online gas chromatographs closer to the wellhead.

The infrastructure and field knowledge that a traditional gas chromatograph requires for installation and ongoing maintenance often does not exist in the production and gathering network environment. The 370XA addresses these concerns by decreasing the infrastructure and utility requirements for installation and operation, and utilizing the local operator interface (LOI) to guide operators through the most common maintenance functions.

The 370XA can be installed outdoors using a four inch diameter pole mount with a sun shield. For other areas where snow or inclement weather is more prevalent, a small cabinet enclosure is ideal because of the 370XA's small footprint, eliminating the high cost of a full size shelter. In addition, low power requirements make solar or natural gas power generators feasible at locations off the power grid.

Power Generation & Fuel Gas Control

Tighter emissions regulations and the need for maximum burner efficiency require the air/fuel ratio to be optimized based on the energy content and quality of the incoming gas. The composition and energy content of the natural gas supplied can vary significantly over a relatively short period of time with little or no notice from the gas provider.

The Rosemount 370XA can measure the quality of the incoming gas and calculate its Wobbe Index to provide feed-forward control to the air/fuel ratio. This can lead to significant improvements in burner efficiency and lower emissions when compared to flue-gas measurements that provide feed-back control. Using the Wobbe Index value from the 370XA, the burner management system can adjust to changes in gas quality before the oxygen, NO_x, or carbon dioxide levels in the flue gas stream increase.

Feed gases with Wobbe Index values outside of the burner's design parameters can result in damage to the burner tip or inefficient combustion leading to flame-outs. Monitoring the feed gas can provide a check on the natural gas supply and help avoid burner damage or unexpected flame-outs.

The Emerson Difference

A key advantage of the 370XA is the compact *Maintainable Module™* that includes the columns, thermal conductivity detectors (TCDs), analytical valves, and solenoids, all within a single enclosure. Providing the technician with easy access to these key components inside a single enclosure is a cost effective way to service or repair the module compared to other GCs that have no serviceable components.

Using a multi layer manifold, which replaces the tubing found in traditional chromatograph ovens to connect the various components in the module, eliminates the need for compression fittings that can be a potential source of leaks

If the *Maintainable Module™* needs repair, it can be quickly and easily replaced in the field without causing major interruptions or delays. Once the replacement module has been properly installed and is back online, the GC will self validate and calibrate before automatically switching to Analysis mode.

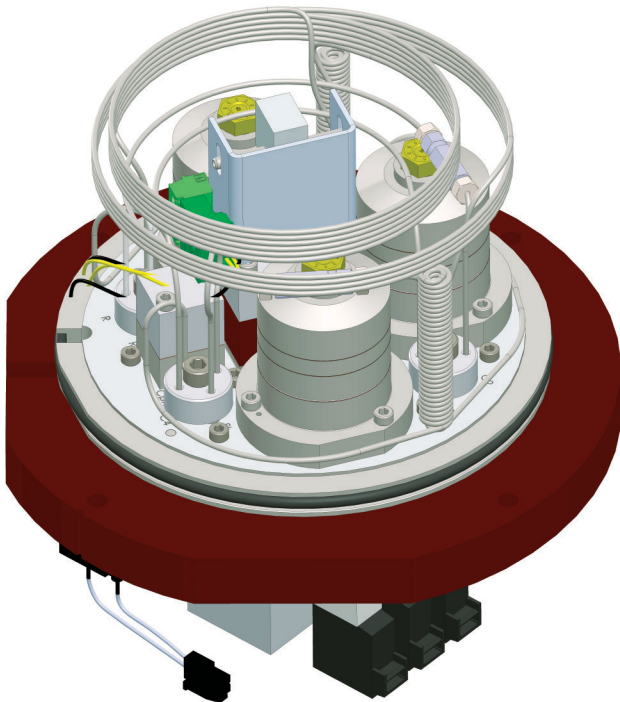

370XA Maintainable Module™

Local Operator Interface (LOI)

A challenging concern in the industry today is the declining experience of operators in the field and the lack of available time to perform routine maintenance service calls. The Rosemount 370XA has a full-color LOI designed to simplify GC operations in the field. The LOI uses a full-VGA LCD interface combined with a 19-key tactile feedback keypad that is rated for Class I, Division 1 hazardous areas.

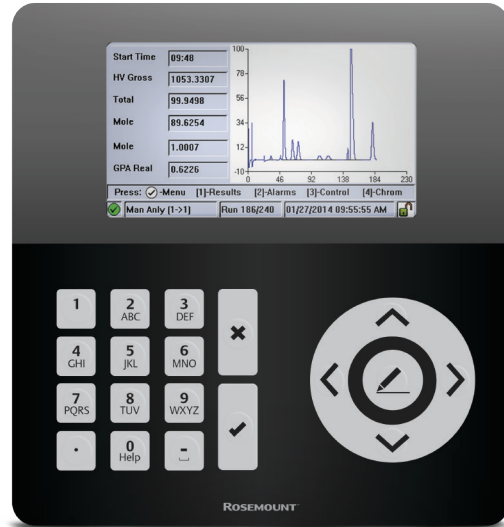

370XA Local Operator Interface (LOI).

You can perform many of the GC's routine maintenance functions directly from the LOI. In most cases, the 370XA can be installed, configured, and placed online without the use of a computer.

Routine Maintenance Functions

- **Changing Calibration Gas** - When replacing the standard calibration gas, built in software assistants in the LOI walk you through these basic steps:
 - Validate the existing calibration according to the thermal conductivity of each of the components
 - Change the calibration bottle
 - Enter new values
 - Purge the calibration gas
 - Analyze the calibration gas to validate the new concentration values
 - Calibrate to the new standard
 - Return to automatic analysis of the stream

■ **Auto-Valve Timing** – Over time, restrictions can build up inside the analytical flow-paths of a gas chromatograph oven. The auto-valve-timing adjusts the analytical valve timings and integration events to optimize the analysis to account for these changes. This reduces the need for fully trained gas chromatograph experts in the field and ensures the analyzer is maintaining the tight tolerances required to reduce mismeasurement.

■ **Module Replacement** – When a module is replaced in the field, the LOI initiates that goes through the purge, validation, and calibration sequence. The status and progress of the module initiation sequence can be monitored from the LOI and will confirm when the analyzer is back online.

Additionally, many of the functions historically performed with a computer can now be done using the LOI, including:

- Viewing, accepting, and clearing alarms
- Stop and starting the analysis cycle
- Viewing chromatograms
- Viewing calibration, validation, and calibration reports
- Viewing archive data and trends
- Viewing and configuring communication settings

Flexible Communication and I/O

You can connect the 370XA to supervisory systems such as flow computers, RTU's, or SCADA systems using two RS-232/485 serial ports or two Ethernet ports. Each serial or Ethernet port can be configured with unique Modbus maps that provide individual read/write access control. You can use the industry standard SIM_2251 Modbus map or a fully customized map based on either the Enron (one register per floating point) or Modicon (two registers per floating point) data formats.

Additionally, two analog output, one analog inputs, one digital input, and one digital output are available on the GC.

One of the Ethernet ports has a RJ-45 connector that you can use to connect to a local computer for maintenance and diagnostic access. This Ethernet port has a switchable DHCP server that can assign an IP address to the connected computer.

Data Archiving and Reports

Every analysis is time and date stamped and archived for retrieval via MON2020™. Pre-configured reports can be displayed, printed or stored internally. Results can be trended directly or exported easily to several common formats such as ASCII text, HTML, and Microsoft® Excel™.

The following kinds of data are available:

- **Archiving** – Assuming a four-minute analysis time, at least 85 days of analysis records and at least 370 days of calibration records (one calibration per day) is archived automatically by time and date.
- **Chromatograms** – Over four days worth of analysis chromatograms, 370 final calibration chromatograms (depending on the analysis time), and user selected “protected chromatograms” that are permanently stored.
- **Drawings and Documents** – User manuals and drawings in several file formats are stored in the 370XA's memory for convenient retrieval with MON2020. This eliminates the risk of manuals and drawings being misplaced. User generated documents such as maintenance checksheets or installation drawings can also be uploaded to the 370XA for later retrieval.

Standard logs and reports include:

- **Audit logs** – Data and event logs that fully conform to API report 21.1 for metering audit purposes and backup to primary systems (flow computer, SCADA, DCS).
- **Event logs** – A continuous record of all operator changes, with time, date, and password-identified user records.
- **Alarm logs** – A continuous record of all historical alarms, time and date stamped with alarm state and description.
- **Maintenance logs** – A “scratch pad” for tracking maintenance or testing performed on the gas chromatograph.
- **Average reports** – hourly, 24-hour, weekly, monthly, and variable averages.
- **Analysis reports** – physical property calculations for component and group analysis and alarms.
- **Raw data reports** – retention times, peak areas, detector number, method, integration start/stop, and peak width for the analysis.
- **Calibration reports** – raw component data, new response factors, retention times, and deviation from last calibration.
- **Final calibration reports** – results from the calibration response factors and retention time adjustments.

MON2020™

The Rosemount 370XA gas chromatograph is designed to operate unattended. If adjustments are needed, our proprietary gas chromatograph software, called MON2020™, allows complete control of the 370XA either locally or remotely.

From within MON2020, you can:

- Start or stop analysis, calibration, or validation cycles
- Generate and save current and historical analysis and calibration reports
- Review and modify analytical settings
- Upload and display multiple chromatograms for comparison
- Upload and trend any of the measured results
- Export data to text, HTML, or Excel for use in third party applications
- Check on original calibration against the last calibration
- Perform GC operation checks and modifications simultaneously
- Upload and view manuals and drawings stored in the gas chromatograph

MON2020 is a Windows® based software that makes analyzer configuration, maintenance, and data collection easy. With intuitive drop-down menus, and fill-in-the-blank tables, even new users can quickly navigate through the software. Users of MON2000 will be familiar with the layout and functionality of MON2020 should be impressed with the additional features that make MON2020 even easier to use.

With its abilities to communicate with your enterprise network and export to numerous file types, MON2020 is a powerful tool that ensures operators, engineers, maintenance personnel, and management have access to critical data, such as current and archived chromatograms, alarm history, event logs, and maintenance logs.

MON2020's chromatogram viewer allows you to view and compare both live and archived chromatograms simultaneously. Despite its small size (less than 100 kb), the chromatogram file (.xcgm) includes analysis and calculation results, integration and valve timing settings, retention time settings, and raw peak data. The chromatogram's small file size also make it very convenient to share via email.

MON2020's trend viewer makes it easy to trend multiple variables on a single chart. To help diagnose process or analysis issues, you can select single or multiple points on the trend viewer; the chromatograms associated with these points will open in the chromatogram viewer. The trends can be saved as trend files or exported as text, CSV, or Microsoft® Excel™ files.

MON2020 can connect to a 370XA via Ethernet directly or over your local or wide area network. MON2020 is equipped with multi-level username and password security settings to limit and control access to the GC, and provide five levels of authority ranging from read-only access to full control of the GC and its data.

MON2020™ Interface

Simple Drop-down Menus

Connect to any GC with a Mouse Click

Full Featured Chromatogram Display

Display Results

Save Chromatograms to Hard Drive

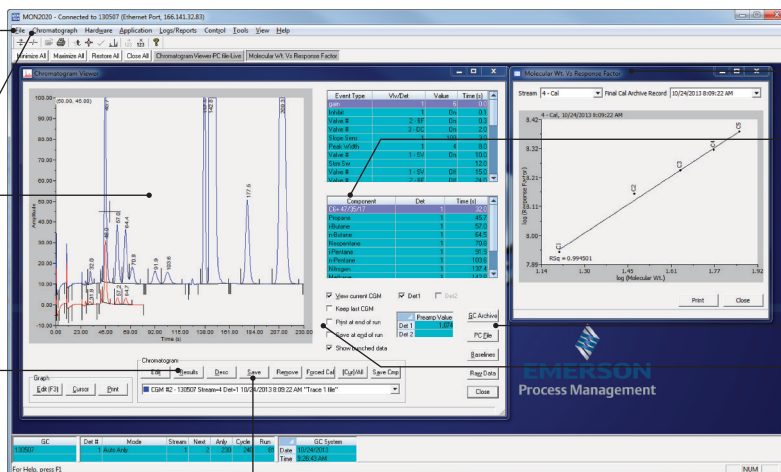

Response Factor Fidelity Chart

Fully Detailed Timed Event Table

Quickly Add Chromatograms to Overlay

Automatic Listing of Measured Components

Specifications

Please consult Rosemount if your requirements are outside the specifications listed below. Improved performance, other products and material offerings may be available depending on the application.

Construction

Environmental temperature:

-20 ° to 60 °C (-4 ° to 140 °F)

Enclosure Protection Rating: IP65 and Type 4X

Dimensions (without sample system or mounts):

460 mm H x 305 mm W x 280 mm D
(18" H x 12" W x 11" D)

Mounting: Pole (standard) or wall mount

Refer to the drawings on the next page for mounting dimensions

An enclosure that offers protection from extreme environmental conditions and from un-authorized third party access is available. All customer connections will be to externally provided connections and all tubing and wiring inside the enclosure will be done at the factory

Approximate Weight (without sample system):

22 kg (50 lbs.)

Area Safety Certification Options:

- **CSA:**
 - USA / Canada
 - Class I, Zone 1, AEx/AEx d IIB + H₂, T6, IP65
 - Class I, Division 1, Groups B, C, D, T6, Enclosure Type 4X
- **ATEX/IECEX**
 - Ex d IIB + H₂ T6, Gb
 - T_a = -20 °C to 60 °C

Warranty: 2 year limited warranty
(see Terms and Conditions for details)

Electronics

Power:

- 24 VDC at the unit (21–30 VDC)
- 55 Watts (Startup)
- < 25 Watts (Steady State)

Performance Capabilities

Application: Four-minute C6+ analysis

Repeatability:

- **Controlled Environment:**
 - ± 0.0125 % Calorific Value
 - (± 0.125 BTU/scf per 1000 BTU/scf)
- **-20 to 60 °C (-4 to 140 °F):**
 - ±0.025 % Calorific Value
 - (± 0.25 BTU/scf per 1000 BTU/scf)

Calculations:

ISO 6976, AGA 8, GPA 2172 (using the GPA 2145 physical properties table)

Carrier Gas: Zero-grade helium. Zero-grade hydrogen available as an option. 6.2 BarG (90 PSIG)

Actuation Gas: Helium, Nitrogen, or clean dry air (90 PSIG)

Sample Input Pressure Range: 0.7 to 1.7 BarG (10 to 30 PSIG)

Valves: Three six-port diaphragm chromatograph valves

Oven: Airless iso-thermal

Detector: Thermal Conductivity Detector (TCD)

Streams: Three-stream plus calibration stream

Chromatograms stored/archived internally: Stores up to 85 days of analysis report data and up to 2500 individual chromatograms

Communications (Standard)

- Ethernet: Two available connections – one RJ-45 port and one four-wire terminal with 10/100 Mbps
- Analog inputs: One standard input filtered with transient protection, 4–20 mA (user scalable and assignable)
- Analog outputs: Two isolated outputs, 4–20 mA
- Digital inputs: One input, user assignable, optically isolated, rated to 30 VDC @ 0.5 A
- Digital outputs: One user-assignable output, Form C and electro-mechanically isolated, 24 VDC
- Serial: Two terminal blocks, configurable as RS-232 or RS-485

Recommended Installation

The drawings below represent the minimum recommended installation guidelines for the Rosemount 370XA gas chromatographs. Please consult Rosemount for detailed installation recommendation of your application.

Pole Mount/Wall Mount

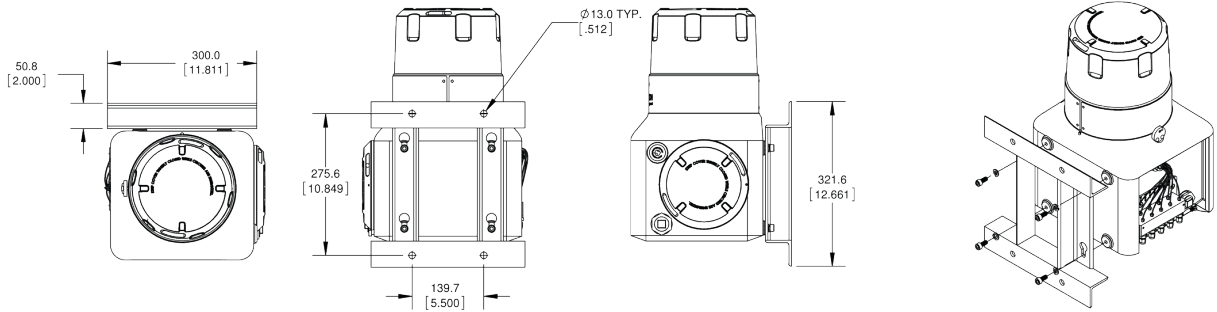

Floor Mount

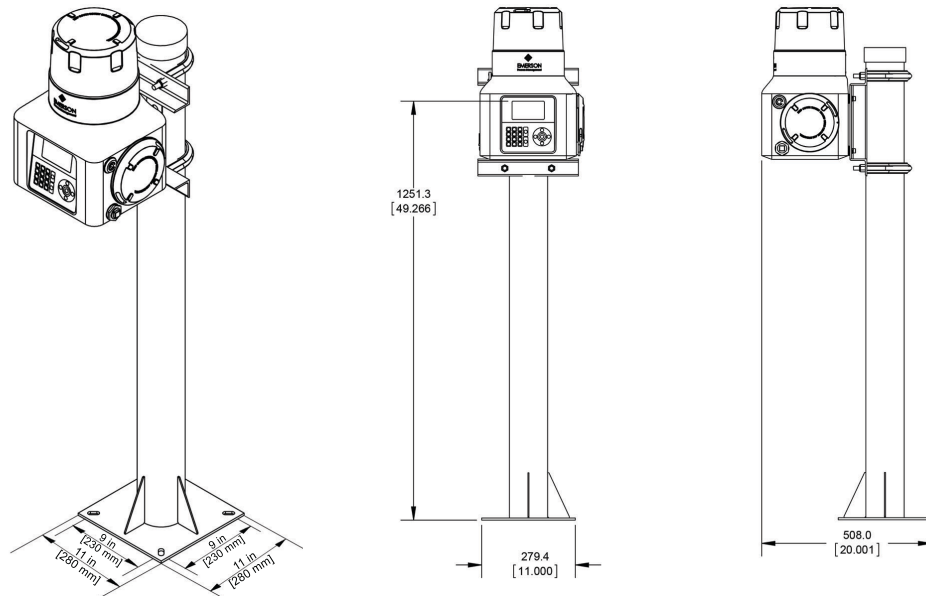

Optional Gas Bottle Cradle Assemblies

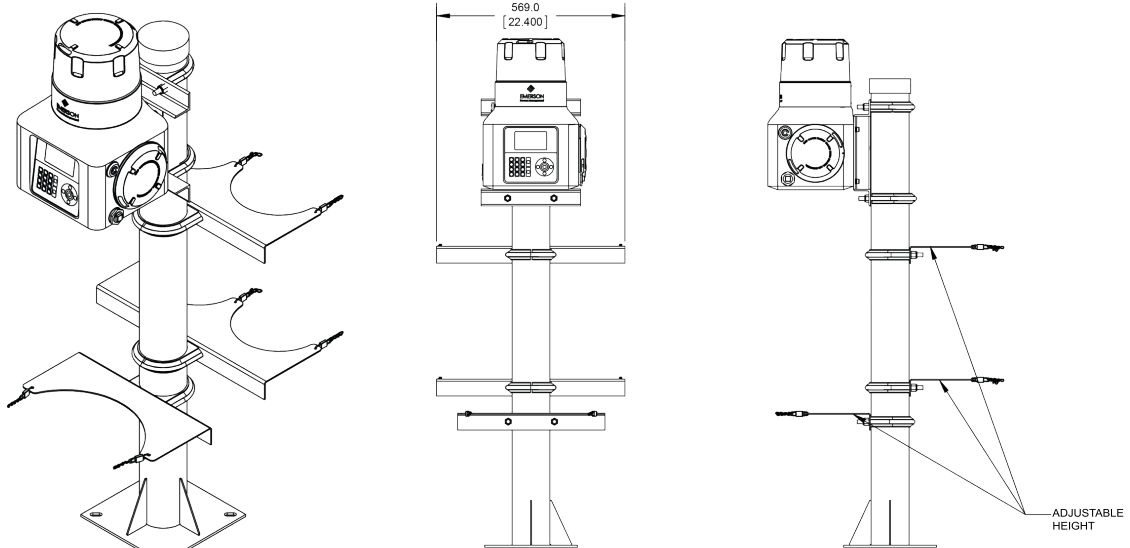

EmersonProcess.com/GasAnalysis



YouTube.com/user/RosemountAnalytical



Analyticexpert.com



Twitter.com/Rosemount_News



Facebook.com/Rosemount

AMERICAS

Emerson Process Management

10241 West Little York, Suite 200
Houston, TX 77040
USA
Toll Free + 866 422 3683
T +1 713 396 8880
F +1 713 466 8175
GC.CSC@Emerson.com

EUROPE

Emerson Process Management AG

Blegistrasse 21
CH-6341 Baar-Walterswil
Switzerland
T + 41 41 768 6111
T + 41 41 761 8740
GC.CSC@Emerson.com

MIDDLE EAST AND AFRICA

Emerson Process Management

Emerson FZE
Jebel Ali Free Zone
Dubai, UAE
P.O. Box 17033
T +971 4 811 8100
F +971 4 886 5465
GC.CSC@Emerson.com

ASIA-PACIFIC

Emerson Process Management

Asia Pacific Private Limited
1 Pandan Crescent
Singapore 0512
Singapore
T +65 6 777 8211
F +65 6 777 0947
GC.CSC@Emerson.com

©2015 Emerson Process Management. All rights reserved.

The Emerson logo is a trademark and service mark of Emerson Electric Co. All other marks are the property of their respective owners.

The contents of this publication are presented for information purposes only, and while effort has been made to ensure their accuracy, they are not to be construed as warranties or guarantees, express or implied, regarding the products or services described herein or their use or applicability. All sales are governed by our terms and conditions, which are available on request. We reserve the right to modify or improve the designs or specifications of our products at any time without notice.