



KTM HINDLE SERIES 300 ULTRA-SEAL TWO PIECE METAL SEATED BALL VALVES INSTALLATION AND MAINTENANCE INSTRUCTIONS

Before installation these instructions must be fully read and understood

WARNING

For safety reasons, it is important to take the following precautions before you start work on the valve:

1. Personnel making any adjustments to the valves should utilize equipment and clothing normally used to work with the process where the valve is installed.
2. The line must be depressurized, drained and vented before installing the valve.
3. Handling and installation of all valves, operators and actuators must be carried out by personnel trained in all aspects of installation and manual/mechanical handling techniques.
4. Ensure the valve pressure/temperature limitations marked on the identification label are above or equal to service conditions.

1 STORAGE / PROTECTION / SELECTION

Storage

When valves are to be stored for some time before being fitted, storage should be in the original delivery crates with any waterproof lining and/or desiccant remaining in place. Storage should be off the ground in a clean, dry, indoor area. If storage is for a period exceeding six months the desiccant bags (if supplied) should be changed at this interval.

Protection

KTM Hindle valves are delivered with protection according to customer's specification, or in accordance with the Quality Assurance Manual, to protect the valve seats and closure member from damage. Wrapping and/or covers should be left in place until immediately before fitting to the pipe.

Selection

Ensure the valve's materials of construction and pressure/temperature limits shown on the identification plate are suitable for the process fluid and conditions. If in doubt contact KTM Hindle.

2 INSTALLATION

1. KTM Hindle Series 300 valves are bi-directional as standard and may be fitted in either direction.
2. Installation may be carried out with stem displaced through any angle permitted by the bolting.
3. Remove protective covers from valve faces.
4. Ensure that mating flanges and gaskets are clean and undamaged.
5. Should there be any possibility of abrasive particles (weld slag, sand etc.) within the piping system, this could damage valve seating/ball. The system will need to be flushed clean.
6. Ensure mating pipe flanges are aligned correctly. Bolting should be easily inserted through mating flange holes.
7. Fit the valve into pipework ensuring easy access of the lever/handwheel.
8. Tighten the flange bolts in a diagonal pattern.

3 OPERATION AND ROUTINE MAINTENANCE

!! Read all warning labels fitted to the valve before operation or maintenance !!

Scope

KTM Hindle Series 300 valves both manual and actuated. For special service designs, typically cryogenic see separate instructions.

Operation

All standard manually operated valves are 'clockwise to close'. The closed position is indicated by either the handlever or indicator arrow being at 90° to the pipe/valve bore axis.

Routine maintenance

No routine maintenance is required other than periodic inspection to ensure satisfactory operation and sealing. Any sign of leakage from the gland packing should be addressed immediately by depressurizing the valve and tightening the gland nut. If no further adjustment is possible, or if seat or joint leakage is suspected, the valve will require a complete overhaul. This should be carried out after depressurisation and in accordance with KTM Hindle Maintenance Instructions. Only KTM Hindle spares should be used.

Spare parts

KTM Hindle valves are identified by a figure number, which is stamped on the identification plate, located on the valve body flange. This reference should be quoted in respect of any after sales queries, spare parts or repair enquiries/orders.

KTM HINDLE SERIES 300 ULTRA-SEAL TWO PIECE METAL SEATED BALL VALVES

INSTALLATION AND MAINTENANCE INSTRUCTIONS

CAUTION

Before attempting any maintenance, ensure the system has been fully depressurized and if necessary drained of any dangerous fluids.

The valve being removed should be operated at least once and left in half open position before removal.

Before disassembling the valve, ensure the valve has been decontaminated correctly from any harmful gasses or fluids and that it is within a safe temperature range for handling.

Personnel making any adjustments to the valves should utilize equipment and clothing normally used to work with the process where the valve is installed.

Handling of all valves, operators and actuators must be carried out by personnel trained in all aspects of manual and mechanical handling techniques.

4 MAINTENANCE

Parts identification

The illustrations in Section 5 show the parts comprising the Series 300 valves.

4.1 Replacement of valve components

If no further adjustment of the gland is possible and stem leakage is still evident or seat leakage is suspected, the valve will need to be removed from the line in order for new seats/seals to be fitted.

After removal of the valve, place the valve on a workbench and adopt the following procedure to remove/replace the seats/seals.

1. Remove connector bolting, and then connector.
2. Remove ball.
3. Remove bottom seat ring and and bottom seat graphite seal.
4. Remove the upper seat from the connector housing.
5. Remove the Wavo spring graphite seal and energizer ring.
6. Remove the operator (lever, gearbox, actuator) in accordance with instructions in Section 4.2.
7. Remove gland nut, tab washer, Belleville washers and gland ring.
8. Remove stem and thrust seal.
9. Remove graphite fire-seals.

Refitting is the reversal of removal.

Before refitting, ensure all sealing and metallic surfaces in seat pockets and stem seal bores are free from damage/corrosion. Minor defects can be polished using abrasive cloth. If major defects are found contact KTM Hindle's service department for possible repair or component exchange.

4.2 Removal and refitting of operator

Removal of handlever/'T'-bar

1. Remove the lever nut/screw and lever washer.
2. Remove the handlever/'T'-bar.

Removal of gearbox/actuator

1. Remove mounting bracket screws.
2. Remove mounting bracket and gearbox/actuator.
3. Remove drive adaptor.

Refitting is the reversal of removal.

4.3 Setting of travel stops on gearbox and actuated operators

(See Fig.3 Section 5 for diagram of travel stop positions)

With valve out of pipeline

1. Close valve fully
2. Remove plastic indicator cover from top of gearbox
3. Release closed stop screw.
4. Align diamond shaped drive points parallel to valve bore as shown in Fig.3 (Section 5).
5. Tighten closed stop screw, allowing for backlash between adaptor and stem.
6. Hold stop screw in position with Allen key and tighten locking nut.
7. Open valve fully.
8. Visibly check that ball port is aligned with valve bore. If incorrect follow rest of procedure.
9. Release open stop screw.
10. Adjust ball position using handwheel until valve is porting correctly.
11. Tighten open stop screw and lock off with locknut.

With valve in pipeline

Adopt steps 1-6 as above for open and closed positions.

NOTE

For the setting of stops on actuators, see separate instructions.

Orientation of gearbox

1. As standard, gearbox input shaft is across line with the offset opposite the valve body connector end.
2. Orientation of input shaft can be rotated through 180° if required. This requires removal of gearbox screws, rotation of gearbox through 180°, and refitting of gearbox screws.

KTM HINDLE SERIES 300 ULTRA-SEAL TWO PIECE METAL SEATED BALL VALVES

INSTALLATION AND MAINTENANCE INSTRUCTIONS

4.4 Actuator assembly

Prior to assembly, check the following details

1. Actuator type and style, i.e. double acting or spring return.
2. Position of actuator in relation to valve and pipeline.
3. Fail-safe position of valve, i.e. open or closed.

Assembly

1. Close valve fully.
2. Remove handle lever nut.
3. Remove handle lever.
4. Remove stop screws and stop collars.
5. Ensure that adaptor coupling is a good fit with actuator drive and valve stem.
6. Position mounting bracket on to valve and fit bracket screws. Do not tighten.
7. Position adaptor coupling on to valve.
8. Assemble actuator over adaptor coupling and on to mounting bracket.
9. Fit actuator screws. Do not tighten.
10. With actuator secure, check for free alignment of adaptor coupling between actuator drive and valve stem. Tighten mounting bracket screws and re-check alignment.

11. With actuator in correct position, tighten actuator screws.

12. If the actuator is fitted with travel stops, adjust to the closed position. Operate to the open position and adjust so that the ball port is aligned with the valve bore.

FIGURE 1 - VALVE AND ACTUATOR DIAGRAM

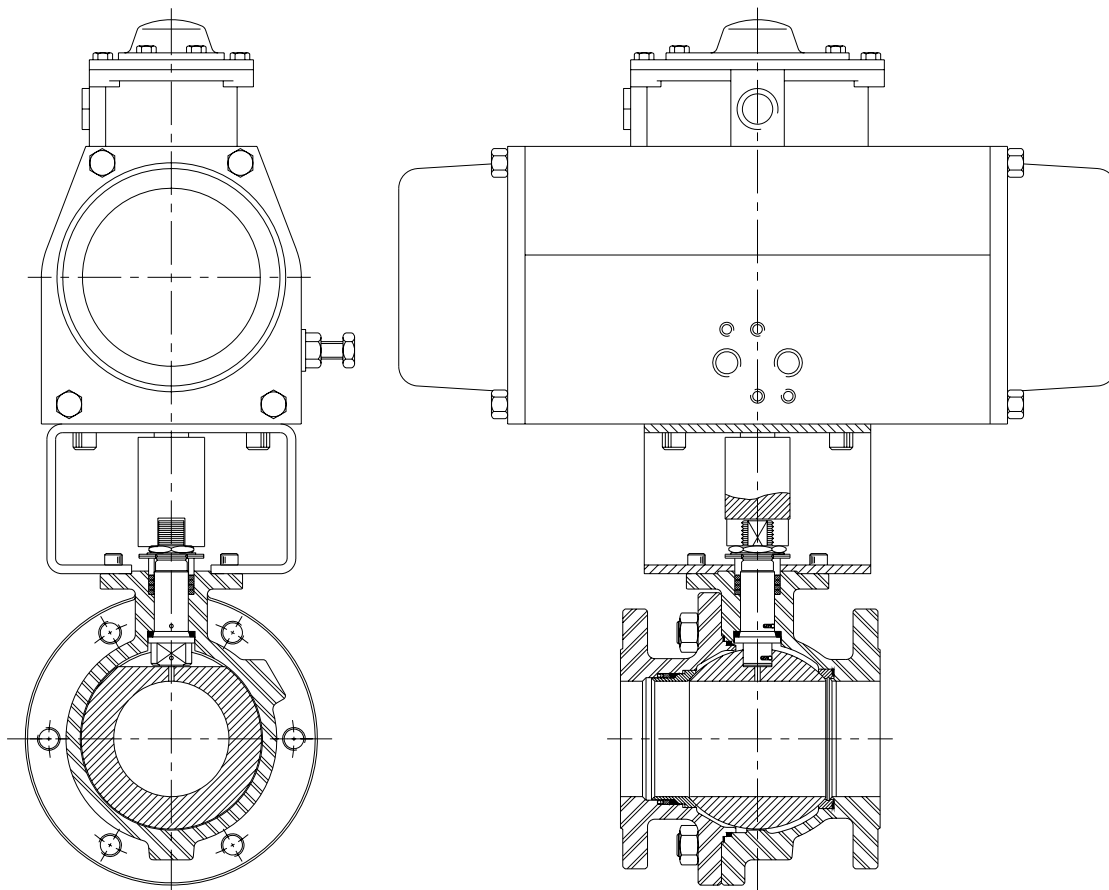

KTM HINDLE SERIES 300 ULTRA-SEAL TWO PIECE METAL SEATED BALL VALVES

INSTALLATION AND MAINTENANCE INSTRUCTIONS

5 COMPONENT AND ASSEMBLY DRAWINGS

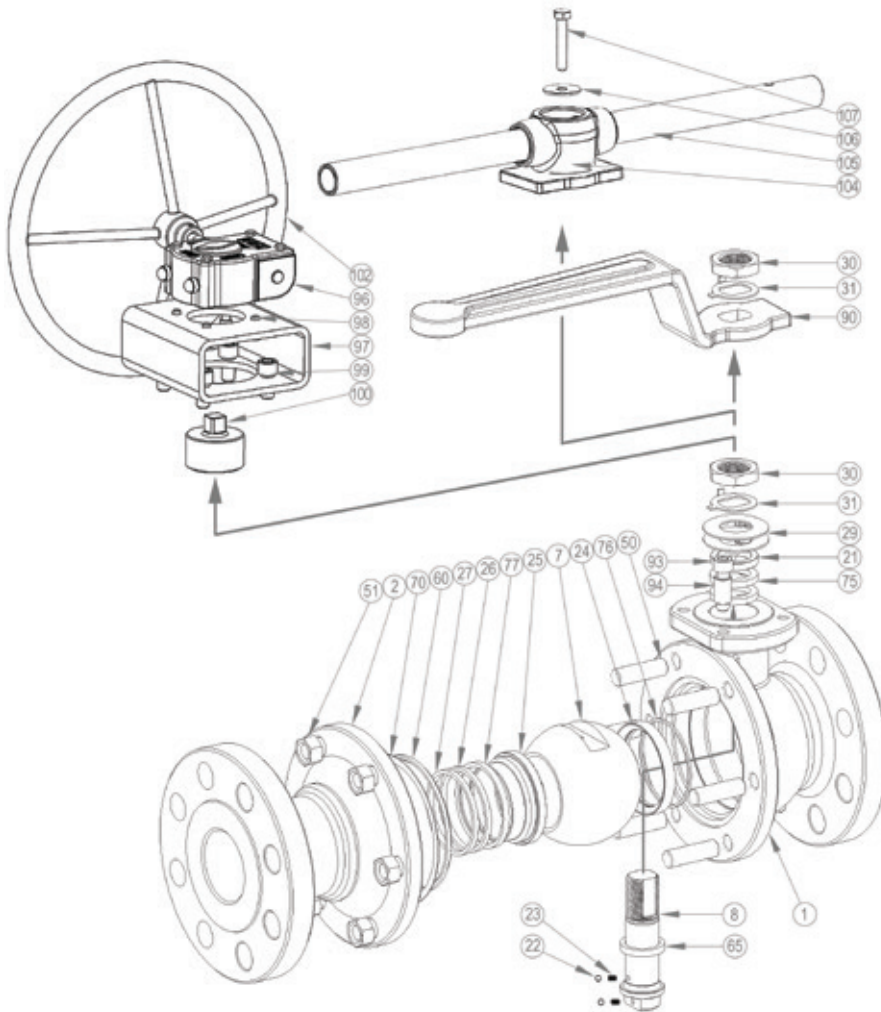

FIGURE 2 - COMPONENT ASSEMBLY DRAWING

PARTS LIST

Item	Component
1	Body
2	Connector
7	Ball
8	Shaft
21	Gland collar
22	Shaft anti-static ball
23	Shaft anti-static spring
24	Body seat
25	Connector seat
26	Seat energizer
27	Seat spring
29	Gland spring
30	Shaft nut
31	Tab washer
50	Body studbolt
51	Body nut
60	Body primary seal
65	Shaft primary seal
75	Shaft fire seal
76	Body seat seal
77	Connector seat seal
90	Handlever
91	Handlever washer
92	Handlever screw
93	Stop screw
94	Stop collar
96	Gearbox
97	Mounting bracket
98	Gearbox screw
99	Bracket screw
100	Coupling
102	Handwheel
104	T-Bar adaptor
105	T-Bar tube
106	T-Bar washer
107	T-Bar screw

Gearbox - Showing travel stop setting screws

1. Indicates closed position stop.
2. Indicates open position stop.

FIGURE 3 - GEARBOX DIAGRAM

