

# Type MR105 Direct-Operated Pressure Reducing Regulators



P1205

TYPE MR105 DIRECT-OPERATED REGULATOR WITH LOW-PRESSURE ACTUATOR



P1204

TYPE MR105 DIRECT-OPERATED REGULATOR WITH HIGH-PRESSURE ACTUATOR

Figure 1. Type MR105 Direct-Operated Pressure Reducing Regulators

## Contents

Introduction.....	2
Specifications .....	2
Features .....	3
Principle of Operation .....	4
Overpressure Protection.....	4
Installation .....	6
Applications .....	6
Universal NACE Compliance.....	8
Capacity Information.....	8
Ordering Information.....	27
Ordering Guide .....	27

## Features

- Travel Indicator
- Large Flow
- Stability
- Fast Response
- Steel and Stainless Steel Constructions Meet API 614 Requirements
- Available Constructions to Meet NACE MR0175-2003 and NACE MR0103 Requirements for Sour Gas Service Capability
- Multiple Trim Materials Available
- ANSI/FCI 70-3-2004 Class VI Shutoff
- Multiple End Connection Options
- $P_1 = P_2$  on High-Pressure Actuator
- Suitable for High-Temperature Applications up to 250°F / 121°C
- Easy Access to Trim Parts
- Drain Valve
- Pressure-Loaded Actuator
- Bleed valve (for High-Pressure Actuator only)



# Bulletin 71.1:MR105

## Specifications

The Specifications section on this page provides the ratings and other specifications for the Type MR105. The following information is stamped on the nameplate fastened on the regulator at the factory: type; body size; maximum inlet, outlet and differential pressure; maximum pressure above setpoint; maximum casing pressure; maximum temperature; spring range; cage type; and trim and diaphragm material.

### Body Sizes and End Connection Styles

See Table 1

### Shutoff Classification per ANSI/FCI 70-3-2004

Class VI (Soft Seat)

### Maximum Inlet, Outlet and Emergency Casing Pressure<sup>(1)</sup>

See Table 3

### Outlet Pressure Ranges<sup>(1)</sup>

5 to 300 psig / 0.34 to 20.7 bar; see Table 2

### Maximum Setpoint<sup>(1)</sup>

**Low-Pressure Actuator:** 43 psig / 3.0 bar

**High-Pressure Actuator:**

*Nitrile (NBR) and Ethylene Propylene (EPDM)*

*Diaphragm:* 300 psig / 20.7 bar

*Fluorocarbon (FKM) Diaphragm:*

150 psig / 10.3 bar

### Construction Materials

See Table 6

### Maximum Differential Pressures<sup>(1)</sup>

See Table 4

### Flow and Sizing Coefficients

See Table 5

### Temperature Capabilities<sup>(1)</sup>

**Nitrile (NBR):** -20 to 180°F / -29 to 82°C

**Fluorocarbon (FKM):** 20 to 250°F / -7 to 121°C<sup>(2)</sup>

**Ethylene Propylene (EPDM)<sup>(3)</sup>:** -20 to 225°F / -29 to 107°C

### Pressure Registration

External

### Downstream Control Line Connection Size

1/2 NPT

### Maximum Pressure Over Setpoint to Avoid Internal Parts Damage<sup>(1)</sup>

**Low-Pressure Actuator:** 20 psig / 1.4 bar

**High-Pressure Actuator:** 120 psig / 8.3 bar

### Spring Case Vent

Type Y602-12

### Pressure-Loaded Spring Case Vent Connection

1/2 NPT

### Approximate Weights

#### For Type MR105 with Low-Pressure Actuator

*NPS 1 / DN 25:* 86 lbs / 39 kg

*NPS 2 / DN 50:* 116 lbs / 53 kg

*NPS 3 / DN 80:* 165 lbs / 75 kg

*NPS 4 / DN 100:* 174 lbs / 79 kg

#### For Type MR105 with High-Pressure Actuator

*NPS 1 / DN 25:* 76 lbs / 34 kg

*NPS 2 / DN 50:* 105 lbs / 48 kg

*NPS 3 / DN 80:* 155 lbs / 70 kg

*NPS 4 / DN 100:* 164 lbs / 74 kg

### Options

- Visual Travel Indicator
- Drain Valve
- Pressure-Loaded Actuator
- NACE Construction
- Bleed Valve (for High-Pressure Actuator Only)
- Ethylene Propylene (EPDM) Elastomer Trim Parts

1. The pressure/temperature limits in this Bulletin or any applicable standard limitation should not be exceeded.

2. Fluorocarbon (FKM) is limited to 200°F / 93°C in hot water.

3. Ethylene Propylene (EPDM) is limited to 20 to 250°F / -7 to 121°C when used with Low Pressure Actuator.

## Introduction

The Type MR105 regulators are direct-operated, pressure reducing, high-capacity, multi-purpose regulators.

They are designed to handle pressures up to 400 psig / 27.6 bar and temperatures up to 250°F / 121°C.

This product provides a simple, fast, reliable and economical way to control and reduce pressure in multi-purpose applications suitable for different flow media such as liquid, air and gas. Applications include lube oil

systems and any application where speed of response is critical, minimum differential pressure is a concern or fluid is not free of impurities. Type MR105 regulator with a low-pressure actuator can be set up to 43 psig / 3.0 bar and the high-pressure actuator version can be set up to 300 psig / 20.7 bar.

The units are available in 4 sizes, NPS 1 through 4 / DN 25 through 100 and are available in several end connection configurations to meet demands on application requirements.

**Table 1. Body Sizes and End Connection Styles**

BODY MATERIAL	END CONNECTION STYLE	
	Body Size	
	NPS 1 and 2 / DN 25 and 50	NPS 3 and 4 / DN 80 and 100
Cast Iron	NPT, CL125 FF, CL250 RF	CL125 FF, CL250 RF
WCC steel <sup>(1)(2)</sup>	NPT, CL150 RF, CL300 RF, CL600 RF or PN 16/25/40 RF	CL150 RF, CL300 RF, CL600 RF or PN 16 RF
CF8M Stainless steel <sup>(1)(2)</sup>	NPT, CL150 RF, CL300 RF, CL600 RF or PN 16/25/40 RF	CL150 RF, CL300 RF, CL600 RF or PN 16 RF
CF3M Stainless steel <sup>(1)(2)</sup>	NPT, CL150 RF, CL300 RF, CL600 RF or PN 16/25/40 RF	CL150 RF, CL300 RF, CL600 RF or PN 16 RF

1. Optional NACE construction available.  
2. Constructions meet API 614 requirements.

**Table 2. Outlet Pressure Ranges**

BODY SIZE, NPS 1 AND 2 / DN 25 AND 50										
Actuator Type	Spring Range		Spring Part Number	Spring Color Code	Spring Wire Diameter		Spring Free Length		Maximum Pressure Over Setpoint to Avoid Internal Parts Damage	
	psig	bar			In.	mm	In.	mm	psig	bar
Low Pressure	5 to 12	0.34 to 0.83	GE42909X012	White	0.437	11.1	9.70	246	20	1.4
	10 to 24	0.69 to 1.6	GE42910X012	Silver	0.500	12.7				
	14 to 32	0.96 to 2.2	GE42911X012	Orange	0.562	14.3				
	18 to 43	1.2 to 3.0	GE43002X012	Red	0.625	15.9				
High Pressure	25 to 60 <sup>(1)</sup>	1.7 to 4.1 <sup>(1)</sup>	GE42907X012	Green	0.375	9.52	9.70	246	120	8.3
	43 to 100	3.0 to 6.9	GE42909X012	White	0.437	11.1				
	75 to 175 <sup>(2)</sup>	5.2 to 12.1 <sup>(2)</sup>	GE42910X012	Silver	0.500	12.7				
	110 to 300 <sup>(2)</sup>	7.6 to 20.7 <sup>(2)</sup>	GE42911X012	Orange	0.562	14.3				
BODY SIZE, NPS 3 AND 4 / DN 80 AND 100										
Actuator Type	Spring Range		Spring Part Number	Spring Color Code	Spring Wire Diameter		Spring Free Length		Maximum Pressure Over Setpoint to Avoid Internal Parts Damage	
	psig	bar			In.	mm	In.	mm	psig	bar
Low Pressure	5 to 8	0.34 to 0.55	GE42909X012	White	0.437	11.1	9.70	246	20	1.4
	8 to 20	0.55 to 1.4	GE42910X012	Silver	0.500	12.7				
	12 to 30	0.83 to 2.1	GE42911X012	Orange	0.562	14.3				
	18 to 39	1.2 to 2.7	GE43002X012	Red	0.625	15.9				
High Pressure	39 to 72	2.7 to 5.0	GE42909X012	White	0.437	11.1	9.70	246	120	8.3
	71 to 175 <sup>(2)</sup>	4.9 to 12.1 <sup>(2)</sup>	GE42910X012	Silver	0.500	12.7				
	110 to 250 <sup>(2)</sup>	7.6 to 17.2 <sup>(2)</sup>	GE42911X012	Orange	0.562	14.3				

1. NPS 2 / DN 50 body size spring range is limited to 45 psig / 3.1 bar.  
2. Maximum setpoint is limited to 150 psig / 10.3 bar for constructions with Fluorocarbon (FKM) diaphragm.

Available in linear and quick opening trim cages for gas and liquid applications, respectively. The cage-guided metal plug provides superior control and stability.

The Type MR105 with steel or stainless steel body construction has been designed to meet API 614 as required by lube oil manufacturers.

## Features

**Travel Indicator**—Travel indicator option provides visual indication of the valve movement from the closed to open position.

**Large Flow**—Able to pass large flow rates with minimal offset from setpoint.

**Stability**—The Type MR105 regulator’s cage-guided metal plug design provides superior control stability of delivery pressure.

**Fast Response**—Direct-operated allows for fast response to meet the most demanding pressure and flow requirements.

**Steel and Stainless Steel Constructions Meet API 614 Requirements**—Steel and Stainless steel body constructions comply with the recommendations of API Standard 614.

**Available Constructions to Meet NACE MR0175-2003 and NACE MR0103 Requirements for Sour Gas Service Capability**—Optional materials are available for applications handling sour gases. These constructions comply with the recommendations of NACE International Standards MR0175 and MR0103.

**Multiple Trim Materials Available**—416, 316 and 316L Stainless steel options are available to meet wider application requirements including demands on lube oil and cooling water applications.

# Bulletin 71.1:MR105

**Table 3. Maximum Inlet, Outlet and Emergency Casing Pressures<sup>(1)</sup>**

BODY MATERIAL	END CONNECTION	MAXIMUM INLET PRESSURE		MAXIMUM OUTLET PRESSURE				MAXIMUM EMERGENCY CASING			
		psig	bar	Low-Pressure Actuator		High-Pressure Actuator <sup>(2)</sup>		Low-Pressure Actuator		High-Pressure Actuator <sup>(2)</sup>	
				psig	bar	psig	bar	psig	bar	psig	bar
Cast Iron	NPT	340	23.4	70	4.8	340	23.4	70	4.8	340	23.4
	CL125 FF	175	12.1			175	12.1			175	12.1
	CL250 RF	400	27.6			400	27.6			400	27.6
WCC steel	NPT	400	27.6	70	4.8	400	27.6	70	4.8	400	27.6
	CL150 RF	245	16.9			245	16.9			245	16.9
	CL300 RF	400	27.6			400	27.6			400	27.6
	CL600 RF					400	27.6			400	27.6
	PN 16 RF	245	16.9			245	16.9			245	16.9
	PN 16/25/40 RF	400	27.6			400	27.6			400	27.6
CF8M Stainless steel	NPT	400	27.6	70	4.8	400	27.6	70	4.8	400	27.6
	CL150 RF	225	15.5			225	15.5			225	15.5
	CL300 RF	400	27.6			400	27.6			400	27.6
	CL600 RF					400	27.6			400	27.6
	PN 16 RF	225	15.5			225	15.5			225	15.5
	PN 16/25/40 RF	400	27.6			400	27.6			400	27.6
CF3M Stainless steel	NPT	400	27.6	70	4.8	400	27.6	70	4.8	400	27.6
	CL150 RF	185	12.7			185	12.7			185	12.7
	CL300 RF	400	27.6			400	27.6			400	27.6
	CL600 RF					400	27.6			400	27.6
	PN 16 RF	185	12.7			185	12.7			185	12.7
	PN 16/25/40 RF	400	27.6			400	27.6			400	27.6

1. Based on a maximum temperature of 250°F / 121°C.

2. Maximum outlet and emergency casing pressures for constructions with Fluorocarbon (FKM) diaphragm are limited to 230 psig / 15.8 bar or the body rating limit, whichever is lower.

**ANSI/FCI 70-3-2004 Class VI Shutoff**—Soft-seat valve plug disks for tight shutoff.

**Multiple End Connection Options**—Type MR105 is available in several end connection configurations to meet demands on application requirements.

**P<sub>1</sub> = P<sub>2</sub> on High-Pressure Actuator**—Inlet pressure rating equals outlet pressure rating on high-pressure actuator constructions up to 400 psig / 27.6 bar.

**Easy Drain**—Feature allows you to drain the system without expensive spool pieces saving you time and space.

**Easy Bleed**—Feature allows you to purge the air trapped underneath the diaphragm when the high-pressure regulator is installed in the upright position, which improves speed of response.

## Principle of Operation

Refer to Figure 2. The Type MR105 is a direct-operated pressure reducing regulator. Downstream pressure is registered externally through a 1/2 NPT control line tapped in the low-pressure actuator bonnet or in the high-pressure actuator lower casing. When downstream demand decreases, the pressure under the actuator diaphragm increases. This pressure overcomes the regulator setting (which is set by the regulator control spring). Through the action of

the actuator stem and valve spring, the valve plug moves closer to the seat ring and reduces flow. When demand downstream increases, pressure under the actuator diaphragm decreases. Spring force pushes the actuator stem downward, the valve plug moves away from the seat ring and the flow increases downstream as the regulator opens in response to the decreased pressure underneath the diaphragm. The downward motion of the plug allows gas to flow through the cage into the downstream system.

Increased downstream pressure permits the regulator to close. The combination of valve spring force and valve plug unbalance provides positive valve plug shutoff against the port and upper seals.

## Overpressure Protection

Type MR105 regulator with the low-pressure actuator has outlet pressure ratings lower than the inlet pressure ratings. Complete downstream overpressure protection is needed if the actual inlet pressure exceeds the outlet pressure rating.

Overpressuring any portion of a regulator or associated equipment may cause personal injury, leakage or property damage due to bursting of pressure-containing parts or explosion of accumulated gas. Provide appropriate pressure-relieving or pressure-limiting devices to ensure

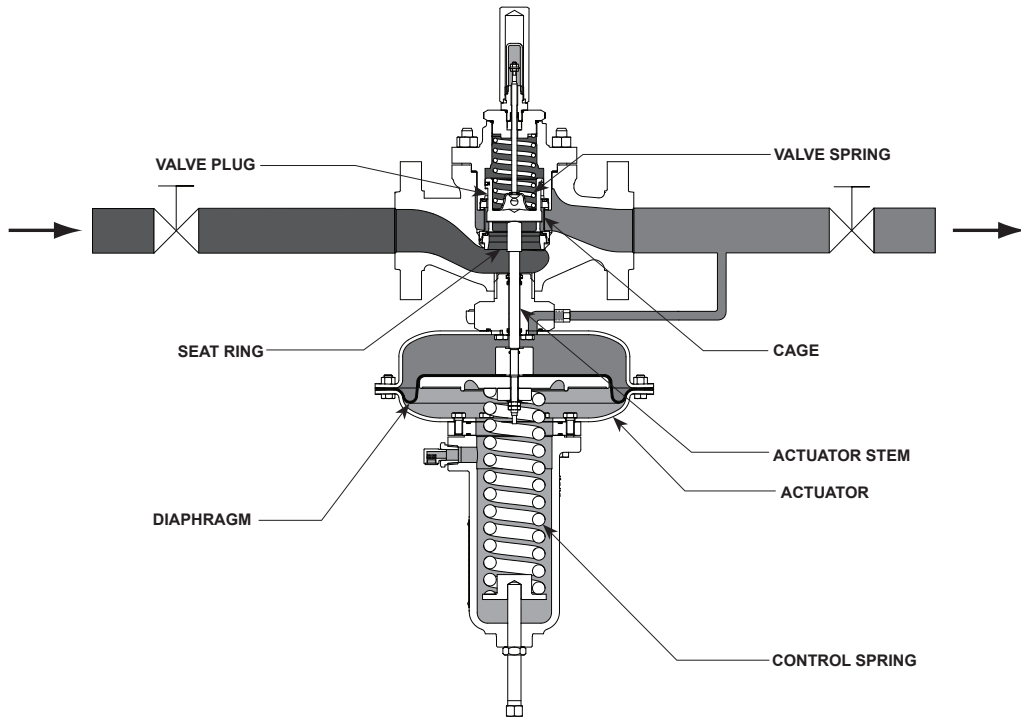

TYPE MR105 WITH LOW-PRESSURE ACTUATOR

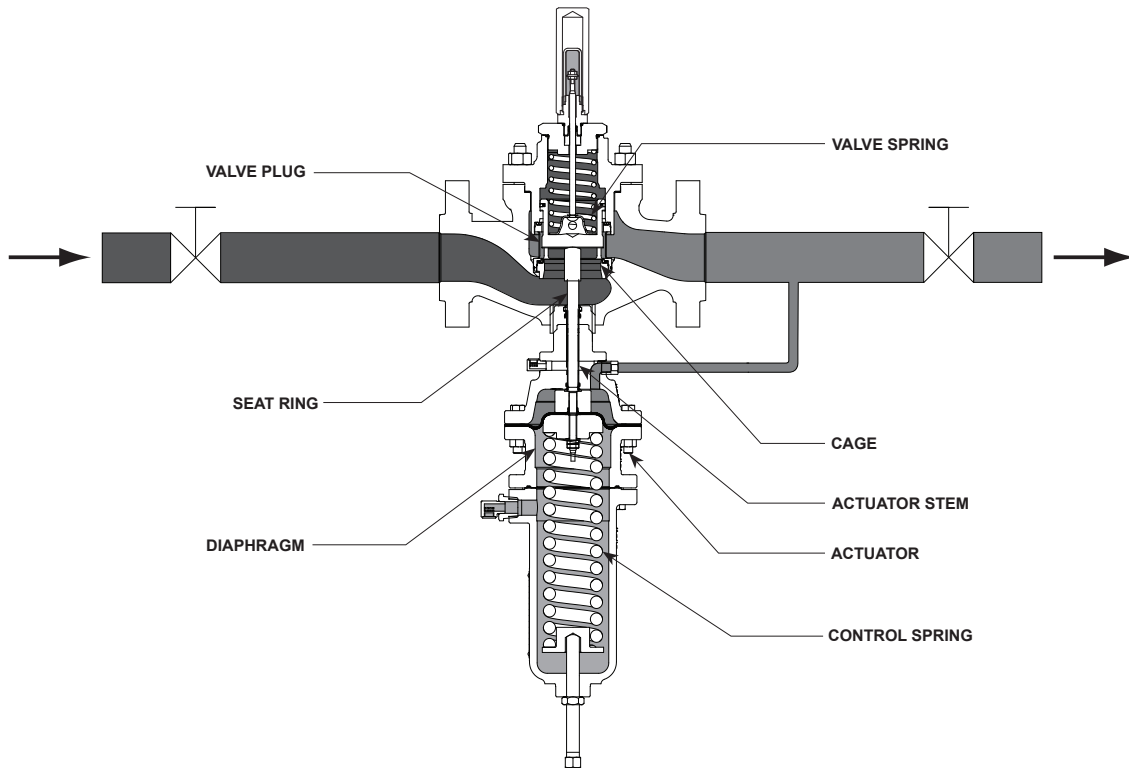

TYPE MR105 WITH HIGH-PRESSURE ACTUATOR

M1178

M1181

- INLET PRESSURE
- OUTLET PRESSURE
- ATMOSPHERIC PRESSURE

Figure 2. Type MR105 Operational Schematic

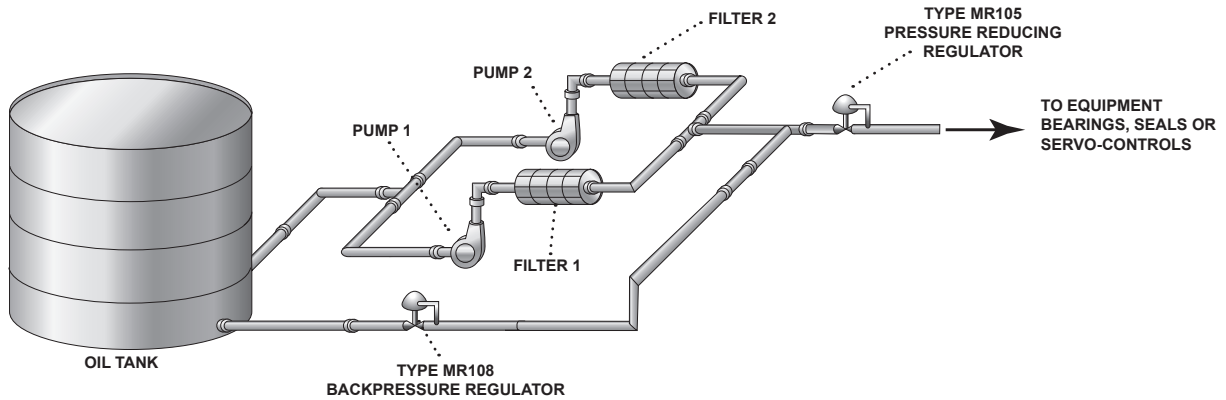

**Figure 3.** Lube Oil Skid Diagram

that the limits in the Specifications section are not exceeded. Regulator operation within ratings does not prevent the possibility of damage from external sources or from debris in the pipeline. A regulator should be inspected for damage periodically and after any overpressure condition. Refer to the relief sizing coefficients in the Specifications and the Capacity Information section to determine the required relief valve capacity.

## Installation

Vertical installation with the actuator installed directly above or below the main valve is recommended but for optimal performance the actuator should be installed below the main valve. The use of a bleed valve is recommended for liquid installations that require the high pressure actuator to be mounted above the main valve. The unit will operate in horizontal installations with the actuator on the side, however, this could result in premature wear of parts. Make sure that flow will be in the same direction as that indicated by the body arrow. Orientation of the two vents should always be down. Vents may be rotated after regulator installation so that the vent screens are down.

A control line must be installed to allow outlet pressure to register on the actuator's diaphragm. The size of the control line is indicated in the Specifications section, and should be installed four to eight pipe diameter downstream of the regulator and in an area of pipe that is free of turbulence.

An instruction manual is provided with every regulator shipped. Refer to this for detailed installation, operation, adjustment and maintenance instructions. Included is a complete listing of individual parts and recommended spare parts.

## Applications

### Note

**A linear cage is recommended for applications where low flow stability is a concern but it will limit the overall capacity of the regulator.**

## Lube Oil Skids (Figure 3)

Lube oil skids maintain oil flow to bearings, seals and servo-controls on critical turbomachinery assets such as air and gas compressors, steam turbines, power recovery turbines and power generating equipment. These skids are essential in keeping lube oil clean at all times and ensure maximum service life for the equipment. Because it is critical to maintain a constant flow and pressure of oil to the equipment, it is normally equipped with two pumps – the main pump and the auxiliary pump, which will take over in case of main pump failure – and filters.

In normal condition, the skids operate in the following manner:

- Lube oil is stored in the tank at atmospheric pressure.
- It is then fed to the main pump (Pump 1) which pressurizes the lube oil.
- Oil then goes through a filter.
- After filtration, oil flow is split such that a fraction is sent to a backpressure regulator to limit the supply pressure to the pressure reducing regulator. 20% of the pump rate flows through the backpressure regulator, sending back oil to the oil tank.
- The pressure reducing regulator decreases the pressure to a safe and allowable range. Flow through this regulator is 80% of pump rate.



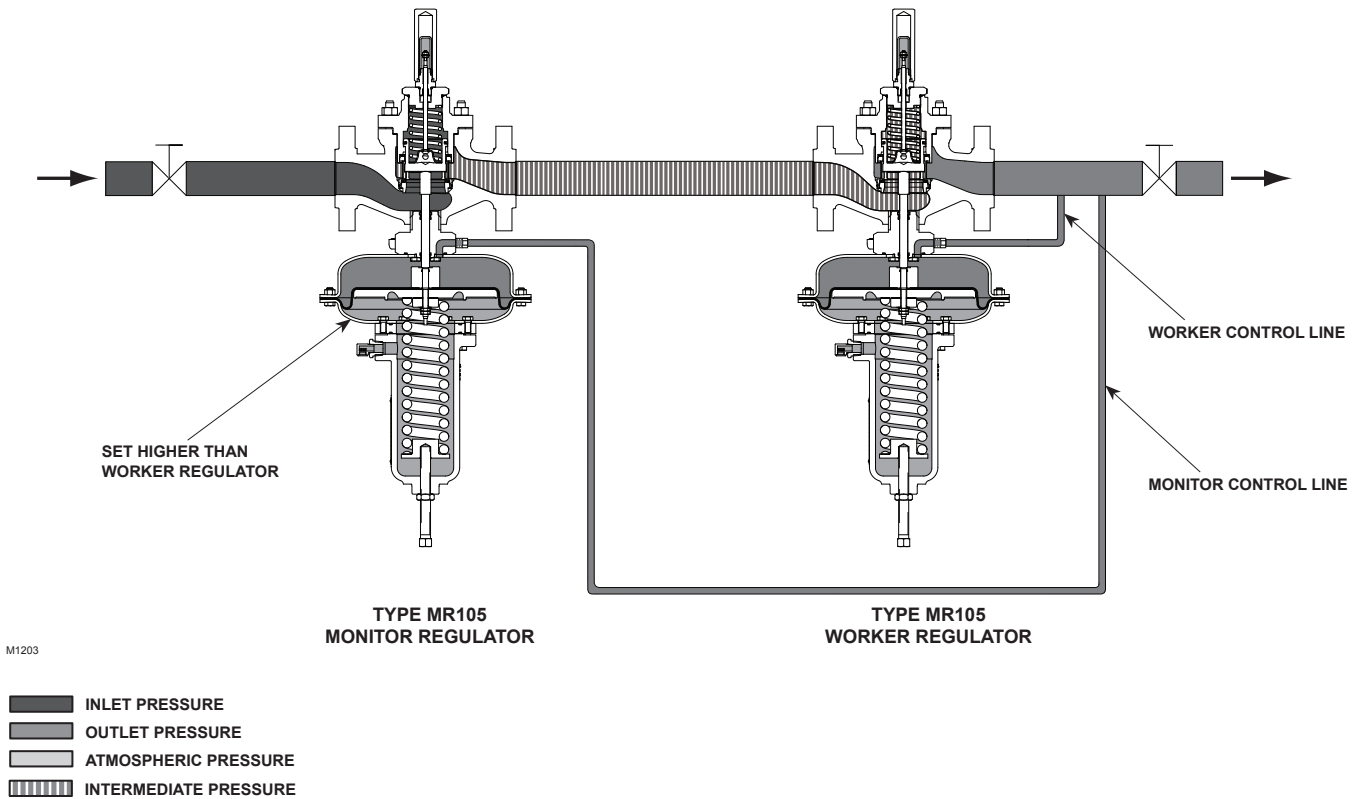

Figure 4. Type MR105 Monitor Regulator Operational Schematic

- Oil flows to large rotating equipment lubricating bearings, e.g. turbines and compressors.

The loss of pressure or flow to the bearings or these turbomachinery assets may shut down the equipment or even the whole plant. Failure of the main pump or filter results in the following upset operation:

- Auxiliary pump (Pump 2) and filter system is brought into operation while main pump is in operation.
- Auxiliary pump ramp up rate is one second.
- Auxiliary pump produces a pressure spike that is beyond the limitations of the pressure reducing regulator.
- The backpressure regulator relieves the excess pressure back to the oil tank. Flow rate is 120% of total pump rate.

Main pump can now be shut down to allow repair of the system. High capacity direct-operated regulators are recommended for this type of application where speed of response is critical. The Type MR105 can provide fast response to the pressure spikes as described above while maintaining a constant delivery pressure of oil to the bearing.

## Wide-Open Monitoring System

Refer to Figure 4. Monitoring system provides overpressure protection by containment and therefore does not vent to the atmosphere. It involves a specific arrangement of two regulators in series which are configured such that if one regulator fails wide open, the other regulator assumes control to maintain the downstream pressure at a set limit. During an overpressure situation, monitoring systems keep the customer on line. Testing is also relatively easy. To perform a periodic test on a monitoring regulator, increase the outlet set pressure of the worker regulator and watch the outlet pressure gauge to determine if the monitor regulator takes over at the appropriate outlet pressure.

In such systems, both regulators are sensing downstream pressure. During normal operation of a wide-open monitor configuration, one regulator (worker) is set at the desired downstream pressure. The other regulator (monitor) is set at a higher pressure and remains wide open. The lock-up pressure will be the worker regulator lock-up pressure. If the worker regulator fails open, the monitor regulator controls the downstream pressure at its setpoint and the lock-up pressure will be the monitor lock-up pressure.

# Bulletin 71.1:MR105

**Table 4. Maximum Differential Pressures**

ACTUATOR TYPE	BODY SIZE		MAXIMUM DIFFERENTIAL PRESSURE			
			Gas Service (Linear Cage)		Liquid Service (Quick Opening Cage)	
	NPS	DN	psid	bar d	psid	bar d
Low Pressure	1	25	400 or maximum inlet pressure, whichever is lower	27.6 or maximum inlet pressure, whichever is lower	200	13.6
	2	50			200	13.6
	3	80			225	15.5
	4	100			225	15.5
High Pressure	1	25	400 or maximum inlet pressure, whichever is lower	27.6 or maximum inlet pressure, whichever is lower	250	17.2
	2	50			200	13.6
	3	80			225	15.5
	4	100			250	17.2

**Table 5. Wide-Open Flow and IEC Sizing Coefficients**

LINEAR CAGE								
Body Size		Wide-Open Flow Coefficient		IEC Sizing Coefficient				
		Line Size Equals Body Size		C <sub>1</sub>	K <sub>m</sub>	F <sub>L</sub>	X <sub>T</sub>	F <sub>d</sub>
NPS	DN	C <sub>g</sub>	C <sub>v</sub>					
1	25	463	13.7	34.0	0.81	0.90	0.73	0.36
2	50	761	22.5	33.8	0.75	0.87	0.72	0.24
3	80	997	30.5	32.7	0.78	0.88	0.68	0.22
4	100	934	27.5	34.0	0.77	0.88	0.75	0.18
QUICK OPENING CAGE								
Body Size		Wide-Open Flow Coefficient		IEC Sizing Coefficient				
		Line Size Equals Body Size		C <sub>1</sub>	K <sub>m</sub>	F <sub>L</sub>	X <sub>T</sub>	F <sub>d</sub>
NPS	DN	C <sub>g</sub>	C <sub>v</sub>					
1	25	597	17.5	34.1	0.81	0.90	0.73	0.43
2	50	1740	48.2	36.1	0.81	0.90	0.82	0.34
3	80	3540	103.1	34.4	0.76	0.87	0.75	0.32
4	100	4300	135.9	31.6	0.72	0.85	0.65	0.30
REDUCED PORT QUICK OPENING CAGE								
Body Size		Wide-Open Flow Coefficient		IEC Sizing Coefficient				
		Line Size Equals Body Size		C <sub>1</sub>	K <sub>m</sub>	F <sub>L</sub>	X <sub>T</sub>	F <sub>d</sub>
NPS	DN	C <sub>g</sub>	C <sub>v</sub>					
2	50	1570	43.8	35.9	0.81	0.90	0.72	0.36

## Universal NACE Compliance

Optional materials are available for applications handling sour gases. These constructions comply with the recommendations of NACE International Sour Service Standards.

The manufacturing processes and materials used by Emerson Process Management Regulator Technologies, Inc. assure that all products specified for sour gas service comply with the chemical, physical and metallurgical requirements of NACE MR0175 and/or NACE MR0103. Customers have the responsibility to specify correct materials. Environmental limitations may apply and shall be determined by the user.

## Capacity Information

### Air Capacities

To determine wide-open flow capacity for relief valve sizing, use one of the following equations:

### For Critical Pressure Drops

Use this equation for critical pressure drops (absolute outlet pressure equal to one-half or less than one-half the absolute inlet pressure).

$$Q = P_{1(abs)} C_g$$

where,

- Q = gas flow rate, SCFH
- C<sub>g</sub> = gas sizing coefficient
- P<sub>1</sub> = absolute inlet pressure, psia

### For Non-Critical Pressure Drops

Use this equation for pressure drops lower than critical (absolute outlet pressure greater than one-half of absolute inlet pressure).

$$Q = \sqrt{\frac{520}{GT}} C_g P_1 \sin \left[ \frac{3417}{C_1} \sqrt{\frac{\Delta P}{P_1}} \right] \text{ DEG}$$



**Table 6. Construction Materials**

PART NAME	STANDARD	OPTIONAL
Body	WCC steel <sup>(1)</sup>	Cast Iron, CF8M, CF3M Stainless steel
Body Flange	WCC steel <sup>(1)</sup>	CF8M, CF3M Stainless steel
Actuator Casings - Low Pressure	AISI 1010 steel <sup>(1)</sup>	316/316L Stainless steel
Actuator Casings - High Pressure	WCC steel <sup>(1)</sup>	CF3M/CF8M Stainless steel
Internal Stiffener Plate	AISI 1010 steel <sup>(1)</sup>	316/316L Stainless steel
Spring Case	WCC steel	CF3M/CF8M Stainless steel
Spring Case Spacer	Zinc-Plated steel	Stainless steel
Cage	CF3M/CF8M (Quick Opening), CF8M (Linear) Stainless Steel	
Valve Plug and Seat Ring	416 Stainless steel	316, 316L, S20910 (Nitronic 50) Stainless steel (NPS 1 / DN 25 body size only)
Closing Spring	Inconel® X750	
Stem	S17400 H1075 Stainless steel	S20910 (Nitronic 50) Stainless steel
Lower Diaphragm Support	S17400 H1075 Stainless steel	
Diaphragm and Seals	Nitrile (NBR)	Fluorocarbon (FKM), Ethylene Propylene (EPDM)
Upper Diaphragm Plate	Cast Iron	
Control/Set Spring	Steel Alloy <sup>(1)</sup>	
Spring Seats	Zinc-Plated steel	
Bolting	SA194 Grade B7/NCF (Body to Bonnet), SAE Grade 5/NCF (Actuator)	Stainless steel
Adjusting Screw	Zinc-Plated steel	Stainless steel

1. Powder coated.

where,

- Q = gas flow rate, SCFH
- G = specific gravity of the gas
- T = absolute temperature of gas at inlet, °Rankine
- C<sub>g</sub> = gas sizing coefficient
- P<sub>1</sub> = absolute inlet pressure, psia
- C<sub>1</sub> = flow coefficient
- ΔP = pressure drop across the regulator, psi

Then, if capacity is desired in normal cubic meters per hour at 0°C and 1.01325 bar, multiply SCFH by 0.0268.

## Liquid Capacities

To determine regulating capacities or to determine wide-open capacities for relief sizing at any inlet pressure, use the following equation.

$$Q = C_v \sqrt{\frac{\Delta P}{G}}$$

where,

- Q = liquid flow rate, GPM
- ΔP = pressure drop across the regulator, psi
- C<sub>v</sub> = regulating or wide-open flow coefficient
- G = specific gravity of the liquid

## Maximum Allowable Pressure Drop for Liquid

Pressure drops in excess of allowable will result in choked flow and possible cavitation damage.

Choked flow is the formation of vapor bubbles in the liquid flowstream causing a condition at the vena contracta which tends to limit flow through the regulator. The vena contracta is the minimum cross-sectional area of the flow stream occurring just downstream of the actual physical restriction.

Cavitation and flashing are physical changes in the process fluid. The change is from the liquid state to the vapor state and results from the increase in fluid velocity at or just downstream of the greatest flow restriction, normally the regulator orifice.

To determine the maximum allowable pressure drop for water:

$$\Delta P_{(allow)} = K_m (P_1)$$

where,

- ΔP = Valve differential in psi
- K<sub>m</sub> = Valve recovery coefficient from Table 5
- P<sub>1</sub> = Valve inlet pressure in psia

Inconel® is a mark owned by Special Metals Corporation.

# Bulletin 71.1:MR105

**Table 7. Typical Air  $C_v$  Coefficient with Linear Cage - Setpoint Made at 10% Flow (for Type MR105 with Low-Pressure Actuator)**

SPRING RANGE, PART NUMBER AND COLOR	SET PRESSURE		INLET PRESSURE		$C_v$ AT % DROOP					
	psig	bar	psig	bar	NPS 1 / DN 25 Body			NPS 2 / DN 50 Body		
					10%	20%	40%	10%	20%	40%
5 to 12 psig / 0.34 to 0.83 bar  GE42909X012 White	5	0.34	25	1.7	2.58	3.69	7.51	2.97	4.52	9.08
			75	5.2	2.55	4.02	8.50	3.52	4.50	9.04
			150	10.3	2.78	3.98	8.95	3.24	4.97	10.3
			250	17.2	2.05	3.24	8.50	3.14	4.81	10.5
	10	0.69	25	1.7	2.56	6.04	13.6	4.66	9.56	20.3
			75	5.2	3.96	7.72	13.7	4.63	8.68	21.9
			150	10.3	3.64	6.80	13.7	3.89	8.39	21.8
			250	17.2	3.84	8.45	13.7	4.34	8.26	20.4
10 to 24 psig / 0.69 to 1.6 bar  GE42910X012 Silver	10	0.69	25	1.7	2.57	4.88	10.9	3.75	6.47	13.1
			75	5.2	2.82	5.05	11.3	3.38	6.06	12.8
			150	10.3	2.80	5.01	11.6	3.56	6.15	14.3
			250	17.2	3.25	5.12	12.7	3.46	6.48	14.3
	15	1.0	25	1.7	3.67	7.36	13.7	4.64	9.99	21.6
			75	5.2	3.81	7.38	13.7	5.03	9.36	22.1
			150	10.3	3.91	7.77	13.7	5.13	9.84	22.1
			250	17.2	3.84	7.85	13.7	4.53	9.84	21.5
	20	1.4	50	3.4	4.68	10.4	13.7	5.98	12.3	22.5
			75	5.2	4.48	9.64	13.7	5.71	11.9	22.5
			150	10.3	4.76	11.0	13.7	4.83	10.5	22.5
			250	17.2	4.89	10.1	13.7	5.92	13.6	22.5
14 to 32 psig / 0.96 to 2.2 bar  GE42911X012 Orange	15	1.0	25	1.7	2.95	5.58	12.1	4.27	7.34	16.5
			75	5.2	2.81	5.54	12.1	3.67	6.49	15.4
			150	10.3	2.86	5.18	11.7	4.05	7.50	16.4
			250	17.2	3.01	5.77	13.3	3.87	7.08	18.3
	20	1.4	25	1.7	3.87	7.67	13.2	4.77	10.4	19.8
			75	5.2	3.42	6.69	13.7	4.51	8.77	21.9
			150	10.3	3.52	6.99	13.7	5.15	9.67	22.0
			250	17.2	3.73	7.26	13.7	4.34	8.94	21.8
	25	1.7	50	3.4	4.68	9.18	13.7	5.12	11.1	22.3
			75	5.2	3.73	8.46	13.7	4.83	11.9	22.3
			150	10.3	4.05	8.79	13.7	5.2	11.4	22.5
			250	17.2	4.06	9.73	13.7	4.78	10.9	22.5
30	2.1	50	3.4	5.18	11.1	13.7	5.77	13.8	22.3	
		75	5.2	4.99	11.2	13.7	6.33	14.1	22.5	
		150	10.3	4.78	11.1	13.7	6.23	14.5	22.4	
		250	17.2	5.53	12.7	13.7	5.29	13.6	22.5	
18 to 43 psig / 1.2 to 3.0 bar  GE43002X012 Red	20	1.4	50	3.4	2.69	5.46	11.2	3.74	7.43	15.5
			75	5.2	2.59	5.13	11.1	4.66	6.60	15.3
			150	10.3	3.03	5.36	11.9	4.19	7.44	16.2
			250	17.2	2.83	5.03	12.0	4.06	7.00	16.8
	25	1.7	50	3.4	3.18	6.49	13.0	4.97	8.82	20.4
			75	5.2	3.67	6.90	13.7	4.11	8.98	20.6
			150	10.3	3.22	6.73	13.7	4.80	8.97	21.0
			250	17.2	3.46	6.66	13.7	4.59	8.76	20.3
	30	2.1	50	3.4	4.41	8.24	13.7	4.77	10.9	21.5
			75	5.2	4.18	8.24	13.7	5.82	10.2	22.1
			150	10.3	3.96	8.30	13.7	5.89	10.9	22.0
			250	17.2	3.79	7.89	13.7	5.04	10.7	22.1
35	2.4	50	3.4	4.70	9.42	13.7	5.93	12.5	21.9	
		75	5.2	4.64	9.11	13.7	6.19	13.1	22.3	
		150	10.3	4.44	9.42	13.7	6.28	12.9	22.4	
		250	17.2	4.41	9.14	13.7	5.69	12.5	22.5	
40	2.8	50	3.4	5.34	11.1	13.7	6.31	15.2	21.7	
		75	5.2	4.55	10.5	13.7	7.17	14.8	22.1	
		150	10.3	4.52	11.0	13.7	5.53	12.1	22.5	
		250	17.2	5.11	11.0	13.7	6.29	14.9	22.5	

- continued -

**Table 7. Typical Air  $C_v$  Coefficient with Linear Cage - Setpoint Made at 10% Flow (for Type MR105 with Low-Pressure Actuator) (continued)**

SPRING RANGE, PART NUMBER AND COLOR	SET PRESSURE		INLET PRESSURE		$C_v$ AT % DROOP					
					NPS 3 / DN 80 Body			NPS 4 / DN 100 Body		
	psig	bar	psig	bar	10%	20%	40%	10%	20%	40%
5 to 8 psig / 0.34 to 0.55 bar  GE42909X012 White	5	0.34	25	1.7	4.96	6.90	12.2	4.72	6.55	10.0
			75	5.2	4.63	6.63	12.2	4.47	6.02	10.6
			150	10.3	4.43	6.60	11.3	4.24	6.06	10.8
			250	17.2	3.97	5.81	11.1	4.39	5.97	10.6
	8	0.55	25	1.7	6.47	10.5	21.7	5.58	8.64	17.5
			75	5.2	5.72	9.35	20.2	5.23	8.25	16.8
			150	10.3	5.22	8.82	19.1	5.32	9.08	17.1
			250	17.2	5.50	9.05	20.1	4.55	7.95	17.2
8 to 20 psig / 0.55 to 1.4 bar  GE42910X012 Silver	10	0.69	25	1.7	5.54	9.22	17.6	4.08	7.67	15.0
			75	5.2	5.79	8.79	17.3	4.75	7.29	15.1
			150	10.3	5.28	8.07	16.9	4.58	6.95	13.8
			250	17.2	5.18	8.34	17.4	4.13	6.69	13.9
	15	1.0	25	1.7	7.06	13.2	29.1	5.78	11.0	23.9
			75	5.2	7.06	12.9	29.1	6.06	10.6	23.3
			150	10.3	6.33	11.9	28.0	5.45	9.91	23.0
			250	17.2	6.68	12.3	27.7	5.28	9.73	23.0
	20	1.4	50	3.4	6.51	13.7	30.5	7.20	13.7	25.3
			75	5.2	8.53	16.8	30.5	7.75	13.9	24.8
			150	10.3	8.19	16.7	30.5	6.71	13.1	27.1
			250	17.2	8.41	16.8	30.5	8.00	13.2	27.4
12 to 30 psig / 0.83 to 2.1 bar  GE42911X012 Orange	15	1.0	25	1.7	5.84	9.95	20.4	4.79	7.80	17.0
			75	5.2	5.71	9.19	19.9	5.00	8.10	16.3
			150	10.3	5.39	9.13	19.5	5.10	8.29	17.1
			250	17.2	5.51	9.10	19.9	5.05	8.28	17.2
	20	1.4	25	1.7	7.94	14.2	28.1	5.15	9.96	22.6
			75	5.2	6.68	12.0	27.7	6.54	11.2	24.5
			150	10.3	6.36	11.4	27.6	6.20	10.8	24.4
			250	17.2	5.72	10.9	26.9	5.37	9.58	22.7
	25	1.7	50	3.4	9.28	15.8	30.5	6.78	12.8	25.3
			75	5.2	7.34	14.6	30.5	6.60	13.3	25.2
			150	10.3	5.83	12.4	30.5	6.76	13.0	25.3
			250	17.2	8.30	15.9	30.5	6.30	12.3	25.5
30	2.1	50	3.4	9.98	17.3	30.5	7.54	16.3	25.1	
		75	5.2	10.3	19.6	30.5	8.23	16.7	25.2	
		150	10.3	8.45	16.8	30.5	7.94	16.1	25.2	
		250	17.2	8.39	18.2	30.5	7.87	16.0	25.4	
18 to 39 psig / 1.2 to 2.7 bar  GE43002X012 Red	20	1.4	50	3.4	5.86	9.73	20.3	4.63	7.98	16.7
			75	5.2	5.77	9.40	20.6	4.94	8.54	16.8
			150	10.3	5.46	9.05	19.9	5.00	8.25	17.1
			250	17.2	5.89	9.60	20.4	5.30	8.59	18.0
	25	1.6	50	3.4	7.28	12.7	26.5	6.02	10.3	22.8
			75	5.2	6.87	12.1	27.1	6.06	10.4	22.4
			150	10.3	5.26	9.59	23.1	6.02	10.3	23.3
			250	17.2	6.59	11.6	26.7	5.67	10.2	23.5
	30	2.1	50	3.4	6.57	13.0	30.5	6.42	11.9	25.8
			75	5.2	8.02	14.6	30.2	6.64	12.1	26.1
			150	10.3	7.09	13.6	29.7	6.49	12.2	25.5
			250	17.2	7.25	13.5	30.5	6.87	12.5	26.8
	35	2.4	50	3.4	10.6	17.5	30.5	7.45	14.2	26.3
			75	5.2	7.36	14.8	30.5	7.97	15.2	26.3
			150	10.3	7.05	14.5	30.5	7.27	14.3	26.6
			250	17.2	7.89	16.0	30.5	7.25	15.0	26.7

# Bulletin 71.1:MR105

**Table 8. Typical Air C<sub>v</sub> Coefficient with Linear Cage - Setpoint Made at 10% Flow (for Type MR105 with High-Pressure Actuator)**

SPRING RANGE, PART NUMBER AND COLOR	SET PRESSURE		INLET PRESSURE		C <sub>v</sub> AT % DROOP									
	psig	bar	psig	bar	NPS 1 / DN 25 Body			NPS 2 / DN 50 Body						
					10%	20%	40%	10%	20%	40%				
25 to 60 psig / 1.7 to 4.1 bar  GE42907X012 Green	25	1.7	50	3.4	2.01	2.74	5.26							
			75	5.2	2.10	3.13	5.83							
			150	10.3	2.17	3.24	6.30							
			250	17.2	2.00	2.99	7.61							
	30	2.1	50	3.4	2.17	3.47	6.61							
			75	5.2	2.73	3.64	7.13							
			150	10.3	2.33	3.66	8.14							
			250	17.2	2.28	3.72	10.1							
	40	2.8	50	3.4	2.48	4.14	8.86							
			75	5.2	2.82	4.64	9.73							
			150	10.3	2.50	4.34	10.6							
			250	17.2	2.72	4.89	13.6							
	50	3.4	75	5.2	2.77	5.11	11.6							
			150	10.3	3.01	5.55	13.6							
			250	17.2	3.07	6.03	13.7							
	60	4.1	75	5.2	3.10	5.69	13.7							
			150	10.3	3.62	6.83	13.7							
			250	17.2	3.50	7.21	13.7							
	25 to 45 psig / 1.7 to 3.1 bar  GE42907X012 Green	25	1.7	50	3.4							3.17	4.27	6.43
				75	5.2							2.74	3.77	6.24
150				10.3	3.18			4.01	6.81					
250				17.2	2.95			3.89	6.64					
30		2.1	50	3.4	2.96			4.15	7.35					
			75	5.2	3.37			4.44	8.00					
			150	10.3	3.30			4.62	8.10					
			250	17.2	3.09			4.35	7.74					
40		2.8	50	3.4	3.41			5.39	9.80					
			75	5.2	3.86			5.66	10.8					
			150	10.3	3.44			5.31	10.5					
			250	17.2	3.60			5.46	10.4					
45		3.1	75	5.2	3.71			5.86	11.6					
			150	10.3	3.67			5.63	11.3					
			250	17.2	3.92			6.01	12.4					
			75	5.2	2.48			4.05	8.07	3.46		5.05	9.51	
43 to 100 psig / 3.0 to 6.9 bar  GE42909X012 White		50	3.4	150	10.3			2.61	4.12	9.19		3.35	4.99	9.34
				250	17.2			2.49	4.07	10.8		3.30	5.12	9.71
				75	5.2			2.71	4.63	10.1		3.75	5.94	11.6
		60	4.1	150	10.3			2.77	4.85	10.9		3.71	5.75	11.3
	250			17.2	2.75	5.01	13.3	3.69	5.81	11.7				
	100			6.9	2.71	5.21	12.2	4.21	6.84	14.9				
	75	5.2	150	10.3	3.33	6.23	13.7	4.24	7.29	15.4				
			250	17.2	3.15	5.93	13.7	3.89	6.84	14.8				
			150	10.3	3.64	7.53	13.7	4.16	8.26	20.0				
	100	6.9	250	17.2	3.57	7.50	13.7	4.37	8.73	21.0				
			75	5.2	100	6.9	2.60	4.35	9.01	3.50	5.02	9.72		
	75 to 175 psig / 5.2 to 12.1 bar  GE42910X012 Silver	75	5.2	250	17.2	2.59	4.17	9.72	3.76	5.63	10.1			
150				10.3	2.71	5.14	11.5	3.62	6.13	13.2				
100		6.9	250	17.2	3.00	5.46	12.7	4.17	6.72	14.2				
			200	13.8	3.34	6.50	13.7	4.13	7.88	17.7				
125		8.6	300	20.7	3.50	6.63	13.7	4.45	8.13	18.5				
			200	13.8	3.94	7.93	13.7	4.90	9.21	21.8				
150		10.3	300	20.7	3.90	8.06	13.7	4.98	9.43	21.8				
			200	13.8	4.06	8.86	13.7	5.34	11.0	22.1				
175		12.1	300	20.7	4.55	9.82	13.7	5.70	11.3	22.5				
			150	10.3	2.38	4.55	9.87	3.52	5.89	12.3				
110 to 300 psig / 7.6 to 20.7 bar  GE42911X012 Orange		125	8.6	250	17.2	2.94	5.07	11.2	3.86	6.56	12.9			
				200	13.8	2.97	5.58	12.7	4.10	7.14	15.3			
	150	10.3	300	20.7	3.08	5.85	13.6	4.37	7.33	16.3				
			250	17.2	3.82	7.75	13.7	4.94	9.20	21.3				
	200	13.8	300	20.7	4.23	8.35	13.7	5.62	10.5	22.1				
			300	20.7	3.90	9.76	13.7	5.66	11.4	22.5				
	250	17.2	350	24.1	5.06	10.2	13.7	6.75	13.7	22.5				
			300	20.7	350	24.1	5.11	11.5	13.7	6.56	14.2	22.5		

☐ - Spring range is not available for the body size.

- continued -

**Table 8. Typical Air  $C_v$  Coefficient with Linear Cage - Setpoint Made at 10% Flow (for Type MR105 with High-Pressure Actuator) (continued)**

SPRING RANGE, PART NUMBER AND COLOR	SET PRESSURE		INLET PRESSURE		$C_v$ AT % DROOP					
	psig	bar	psig	bar	NPS 3 / DN 80 Body			NPS 4 / DN 100 Body		
					10%	20%	40%	10%	20%	40%
39 to 72 psig / 2.7 to 5.0 bar  GE42909X012 White	40	2.8	75	5.2	3.57	4.93	7.96	3.48	4.79	7.68
			150	10.3	4.00	5.45	8.86	3.82	5.20	8.44
			250	17.2	3.87	5.22	8.48	3.68	4.97	8.08
	50	3.4	75	5.2	4.00	5.46	9.98	3.93	5.34	9.68
			150	10.3	3.91	5.49	10.0	3.75	5.25	9.57
			250	17.2	3.89	5.50	9.74	3.70	5.24	9.28
	60	4.1	75	5.2	4.35	6.74	12.4	4.30	6.63	12.1
			150	10.3	3.96	6.06	11.8	3.82	5.82	11.3
			250	17.2	4.54	6.52	12.3	4.32	6.21	11.7
	70	4.8	100	6.9	4.24	6.85	14.0	4.17	6.71	13.6
			150	10.3	4.52	7.11	14.0	4.38	6.86	13.4
			250	17.2	4.51	6.90	14.0	4.30	6.57	13.4
71 to 175 psig / 4.9 to 12.1 bar  GE42910X012 Silver	75	5.2	100	6.9	4.22	6.23	11.4	4.16	6.11	11.0
			150	10.3	4.53	6.56	11.8	4.39	6.35	11.4
			250	17.2	4.30	6.21	11.0	4.11	5.92	10.5
	100	6.9	150	10.3	3.56	6.26	13.4	3.49	6.11	13.0
			250	17.2	4.76	7.42	14.5	4.58	7.11	13.8
			200	13.8	5.49	9.09	19.5	5.37	8.84	18.8
	125	8.6	300	20.7	5.36	8.78	18.7	5.16	8.42	17.8
			200	13.8	5.80	10.3	23.4	5.71	10.1	22.7
			300	20.7	5.91	10.3	22.7	5.72	9.97	21.7
	150	10.3	200	13.8	4.86	9.89	26.3	4.82	9.74	25.6
			300	20.7	6.86	12.4	28.4	6.68	12.0	27.3
			150	10.3	4.40	7.06	14.3	4.35	6.95	13.9
110 to 250 psig / 7.6 to 17.2 bar  GE42911X012 Orange	125	8.6	250	17.2	4.56	6.81	13.5	4.41	6.57	12.9
			200	13.8	5.08	8.27	17.4	5.00	8.10	16.9
			300	20.7	4.16	7.07	15.2	4.03	6.82	14.6
	150	10.3	250	17.2	6.42	11.1	24.4	6.33	10.9	23.7
			300	20.7	6.83	11.5	25.1	6.69	11.2	24.3
			300	20.7	7.58	13.5	29.6	7.49	13.3	27.5
	250	17.2	350	24.1	8.40	15.1	29.5	8.24	14.7	27.5

# Bulletin 71.1:MR105

**Table 9. Typical Water  $C_v$  Coefficient with Quick Opening Cage - Setpoint Made at 10% Flow (for Type MR105 with Low-Pressure Actuator)**

SPRING RANGE, PART NUMBER AND COLOR	SET PRESSURE		INLET PRESSURE		C <sub>v</sub> AT % DROOP								
					NPS 1 / DN 25 Body			NPS 2 / DN 50 - Reduced Port			NPS 2 / DN 50 Body		
	psig	bar	psig	bar	10%	20%	40%	10%	20%	40%	10%	20%	40%
5 to 12 psig / 0.34 to 0.83 bar  GE42909X012 White	5	0.34	25	1.7	5.30	10.9	17.5	8.17	14.3	24.6	11.9	22.7	39.5
			75	5.2	5.00	10.5	17.5	8.81	14.3	21.5	11.0	21.2	33.2
			150	10.3	4.51	9.86	16.8	8.59	12.4	17.4	11.5	19.0	31.8
	10	0.69	25	1.7	8.75	17.1	17.5	12.5	23.2	42.9	18.3	37.5	48.2
			75	5.2	9.11	17.5	17.5	12.2	20.6	35.5	17.8	31.4	48.2
			150	10.3	9.45	16.9	17.5	11.9	17.1	29.8	16.9	26.8	44.2
10 to 24 psig / 0.69 to 1.6 bar  GE42910X012 Silver	10	0.69	25	1.7	7.25	14.6	17.5	10.0	18.8	33.1	15.3	30.0	48.2
			75	5.2	6.52	14.0	17.5	10.3	17.4	28.6	14.6	25.8	41.5
			150	10.3	6.68	14.5	17.5	9.71	14.9	24.1	14.7	24.0	36.3
	15	1.0	25	1.7	10.9	17.5	17.5	13.6	28.5	43.8	20.9	44.0	48.2
			75	5.2	8.29	16.0	17.5	14.2	26.7	42.6	18.1	33.9	48.2
			150	10.3	8.33	16.8	17.5	12.2	20.1	33.9	17.3	30.8	48.2
	20	1.4	50	3.4	9.90	17.5	17.5	14.8	30.2	43.8	23.3	44.4	48.2
			75	5.2	10.7	17.5	17.5	15.9	29.1	43.8	22.3	42.6	48.2
			150	10.3	11.4	17.5	17.5	13.7	25.7	43.2	19.5	37.8	48.2
14 to 32 psig / 0.96 to 2.2 bar  GE42911X012 Orange	15	1.0	25	1.7	7.08	15.2	17.5	10.6	20.2	36.7	15.6	33.5	48.2
			75	5.2	7.65	15.0	17.5	11.2	19.2	33.1	15.7	28.8	47.8
			150	10.3	7.11	14.7	17.5	10.7	16.8	28.1	14.8	26.9	46.5
	20	1.4	25	1.7	9.07	17.5	17.5	14.0	31.2	43.8	20.0	47.0	48.2
			75	5.2	9.93	17.3	17.5	14.3	27.1	43.3	19.9	40.1	48.2
			150	10.3	9.40	17.1	17.5	12.3	21.0	36.3	19.3	38.4	48.2
	25	1.7	50	3.4	9.53	17.5	17.5	16.6	33.2	43.8	24.2	47.2	48.2
			75	5.2	12.4	17.5	17.5	16.3	32.4	43.8	22.1	42.1	48.2
			150	10.3	9.92	17.5	17.5	14.0	25.6	43.8	20.3	39.9	48.2
	30	2.1	50	3.4	11.7	17.5	17.5	16.7	34.7	43.8	25.0	48.2	48.2
			75	5.2	11.8	17.5	17.5	17.6	33.9	43.8	23.7	47.1	48.2
			150	10.3	11.8	17.5	17.5	15.5	29.3	43.8	22.0	40.8	48.2
18 to 43 psig / 1.2 to 3.0 bar  GE43002X012 Red	20	1.4	50	3.4	6.89	14.4	17.5	10.8	20.3	35.2	15.9	29.8	48.2
			75	5.2	7.55	14.9	17.5	11.3	19.6	34.1	15.9	29.4	48.2
			150	10.3	6.88	14.4	17.5	11.0	18.2	29.5	15.7	28.2	44.9
	25	1.7	50	3.4	8.77	16.4	17.5	12.8	26.0	43.8	19.1	39.6	48.2
			75	5.2	8.28	16.8	17.5	13.5	24.4	41.6	19.0	35.8	48.2
			150	10.3	8.86	16.8	17.5	12.0	19.5	33.3	18.2	32.4	48.2
	30	2.1	50	3.4	9.80	17.5	17.5	14.4	30.0	43.8	22.7	46.8	48.2
			75	5.2	9.53	17.5	17.5	15.0	27.7	43.8	20.5	39.2	48.2
			150	10.3	10.5	17.5	17.5	12.8	22.6	39.5	19.4	38.3	48.2
	35	2.4	50	3.4	10.2	17.5	17.5	17.0	34.6	43.8	25.1	48.2	48.2
			75	5.2	10.3	17.5	17.5	16.8	31.6	43.8	23.7	45.6	48.2
			150	10.3	11.5	17.5	17.5	14.1	26.3	43.8	21.8	40.6	48.2
	40	2.8	50	3.4	10.7	17.5	17.5	17.4	38.6	43.8	25.1	48.2	48.2
			75	5.2	11.2	17.5	17.5	18.9	35.3	43.8	25.3	48.2	48.2
			150	10.3	12.2	17.5	17.5	15.5	29.9	43.8	24.3	44.3	48.2

- continued -



**Table 9. Typical Water  $C_v$  Coefficient with Quick Opening Cage - Setpoint Made at 10% Flow (for Type MR105 with Low-Pressure Actuator) (continued)**

SPRING RANGE, PART NUMBER AND COLOR	SET PRESSURE		INLET PRESSURE		$C_v$ AT % DROOP					
	psig	bar	psig	bar	NPS 3 / DN 80 Body			NPS 4 / DN 100 Body		
					10%	20%	40%	10%	20%	40%
5 to 8 psig / 0.34 to 0.55 bar  GE42909X012 White	5	0.34	25	1.7	19.2	32.7	55.3	24.3	44.4	75.2
			75	5.2	17.4	27.8	43.0	23.8	38.0	61.1
			150	10.3	17.3	22.6	37.2	24.2	34.8	49.5
	8	0.55	25	1.7	23.5	46.1	80.5	28.7	65.4	113
			75	5.2	21.6	36.8	61.9	29.7	52.1	86.9
			150	10.3	19.9	29.3	50.3	27.2	44.8	71.0
8 to 20 psig / 0.55 to 1.4 bar  GE42910X012 Silver	10	0.69	25	1.7	22.5	43.2	75.3	29.8	57.5	100
			75	5.2	20.9	35.6	62.6	28.9	50.6	84.4
			150	10.3	20.4	31.6	51.9	27.8	43.5	71.7
	15	1.0	25	1.7	29.8	62.4	103	36.9	82.1	136
			75	5.2	27.7	51.3	85.0	33.7	71.0	124
			150	10.3	23.2	40.9	72.2	35.0	58.9	99.9
	20	1.4	50	3.4	32.9	68.7	103	40.8	92.5	136
			75	5.2	30.6	64.7	103	40.3	86.8	136
			150	10.3	28.3	51.6	91.2	38.4	70.1	127
12 to 30 psig / 0.83 to 2.1 bar  GE42911X012 Orange	15	1.0	25	1.7	25.4	50.4	91.1	30.7	64.5	119
			75	5.2	23.6	42.2	72.7	28.4	55.2	94.8
			150	10.3	21.5	36.0	62.1	29.5	51.0	83.1
	20	1.4	25	1.7	30.6	70.3	103	38.6	91.0	136
			75	5.2	28.0	54.6	94.0	34.6	68.1	124
			150	10.3	23.8	43.6	77.6	35.4	62.4	103
	25	1.7	50	3.4	32.6	67.4	103	42.9	90.1	136
			75	5.2	32.6	66.0	103	39.9	82.8	136
			150	10.3	28.9	54.9	92.3	39.4	73.7	126
			250	17.2	27.1	46.8	79.3	36.0	61.3	106.9
	30	2.1	50	3.4	38.2	81.7	103	47.1	107	136
			75	5.2	38.4	76.8	103	46.5	98.2	136
			150	10.3	32.5	64.1	103	43.8	86.0	136
			250	17.2	29.6	52.6	84.3	40.8	73.2	124.2
	18 to 39 psig / 1.2 to 2.7 bar  GE43002X012 Red	20	1.4	50	3.4	24.6	46.3	80.3	30.6	57.4
75				5.2	24.1	43.8	77.1	29.7	57.0	99.8
150				10.3	21.8	38.1	65.0	29.0	50.2	87.2
25		1.7	50	3.4	28.4	56.4	103	36.4	70.1	127
			75	5.2	29.5	54.2	94.0	32.9	68.2	121
			150	10.3	24.0	45.4	78.8	33.2	61.1	104
			250	17.2	23.9	39.9	66.1	31.9	53.8	91.0
30		2.1	50	3.4	31.7	65.8	103	38.8	83.4	136
			75	5.2	32.5	64.2	103	37.2	79.0	136
			150	10.3	27.5	54.9	92.8	36.0	71.0	121
			250	17.2	25.6	45.4	79.0	34.7	60.9	106.3
35		2.4	50	3.4	36.0	77.2	103	42.8	99.4	136
	75		5.2	37.0	74.6	103	41.1	88.9	136	
	150		10.3	31.1	61.8	103	38.7	80.4	136	
	250		17.2	28.7	52.4	88.5	39.5	71.3	122	

# Bulletin 71.1:MR105

**Table 10. Typical Water  $C_v$  Coefficient with Quick Opening Cage - Setpoint Made at 10% Flow (for Type MR105 with High-Pressure Actuator)**

SPRING RANGE, PART NUMBER AND COLOR	SET PRESSURE		INLET PRESSURE		C <sub>v</sub> AT % DROOP											
	psig	bar	psig	bar	NPS 1 / DN 25 Body			NPS 2 / DN 50 - Reduced Port			NPS 2 / DN 50 Body					
					10%	20%	40%	10%	20%	40%	10%	20%	40%			
25 to 60 psig / 1.7 to 4.1 bar  GE42907X012 Green	25	1.7	50	3.4	4.39	8.73	15.5									
			75	5.2	4.83	9.38	16.4									
			150	10.3	4.87	11.7	17.5									
			250	17.2	4.10	17.5	17.5									
	30	2.1	50	3.4	4.80	10.0	17.3									
			75	5.2	5.34	10.8	17.5									
			150	10.3	5.59	14.0	17.5									
			250	17.2	5.33	17.5	17.5									
	40	2.8	50	3.4	5.88	13.2	17.5									
			75	5.2	7.05	13.7	17.5									
			150	10.3	7.68	16.8	17.5									
			250	17.2	9.43	17.5	17.5									
	50	3.4	75	5.2	7.30	15.3	17.5									
			150	10.3	9.17	17.5	17.5									
			250	17.2	15.9	17.5	17.5									
			75	5.2	8.07	17.1	17.5									
60	4.1	150	10.3	10.9	17.5	17.5										
		250	17.2	15.8	17.5	17.5										
		75	5.2	6.02	12.4	17.5	8.40	15.9	28.6	11.9	23.6	43.0				
25 to 45 psig / 1.7 to 3.1 bar  GE42907X012 Green	25	1.7	50	3.4							7.25	12.1	19.6	9.73	16.2	28.9
			75	5.2							8.14	12.8	19.5	11.2	17.8	27.9
			150	10.3							7.35	11.3	17.3	10.3	16.0	24.8
	30	2.1	50	3.4							7.30	13.3	23.4	10.2	18.9	33.7
			75	5.2							8.66	14.1	22.9	12.3	20.4	32.6
			150	10.3							7.48	12.4	20.5	11.0	18.3	29.5
	40	2.8	50	3.4							8.82	17.7	31.9	13.4	27.6	48.2
			75	5.2							10.9	18.4	30.8	15.4	26.8	45.4
			150	10.3							8.71	15.2	26.0	13.9	23.0	39.8
	45	3.1	75	5.2							8.68	16.9	31.2	13.1	25.4	46.6
			150	10.3							9.27	16.1	29.4	12.6	24.8	43.0
			75	5.2							6.73	13.8	17.5	8.78	15.2	26.3
43 to 100 psig / 3.0 to 6.9 bar  GE42909X012 White	50	3.4	150	10.3	8.03	17.5	17.5	8.45	13.9	23.2	11.9	20.4	37.4			
			250	17.2	8.03	17.5	17.5	8.45	13.9	23.2	11.9	20.4	37.4			
			75	5.2	6.76	14.4	17.5	9.60	19.0	35.0	13.5	28.0	48.2			
	60	4.1	150	10.3	7.76	15.6	17.5	9.80	17.1	30.7	15.3	27.9	48.2			
			250	17.2	8.36	17.5	17.5	8.93	15.6	26.6	13.9	25.7	46.8			
			100	6.9	7.89	16.2	17.5	9.82	20.9	39.5	15.3	32.5	48.2			
	75	5.2	250	17.2	12.4	17.5	17.5	10.2	18.1	32.6	15.5	29.7	48.2			
			150	10.3	10.1	17.5	17.5	11.9	24.7	43.8	17.0	38.7	48.2			
			250	17.2	13.0	17.5	17.5	13.0	23.5	43.1	19.1	40.0	48.2			
	75 to 175 psig / 5.2 to 12.1 bar  GE42910X012 Silver	100	6.9	100	6.9	5.79	12.5	17.5	8.07	15.8	29.6	11.9	24.5	45.1		
				250	17.2	6.22	13.9	17.5	9.18	15.6	26.2	12.4	22.1	41.6		
				150	10.3	7.23	15.2	17.5	9.30	18.7	35.9	14.7	29.8	48.2		
125		8.6	250	17.2	8.54	16.7	17.5	11.1	19.5	34.0	15.7	28.1	48.2			
			200	13.8	8.66	17.4	17.5	11.1	22.4	40.8	16.6	33.9	48.2			
			300	20.7	10.9	17.5	17.5	12.1	22.0	39.6	16.7	35.5	48.2			
150		10.3	200	13.8	9.92	17.5	17.5	12.8	26.5	43.8	19.0	40.5	48.2			
			300	20.7	11.9	17.5	17.5	14.4	26.1	43.8	21.7	43.3	48.2			
			200	13.8	10.6	17.5	17.5	14.4	33.5	43.8	21.0	48.2	48.2			
175		12.1	300	20.7	12.4	17.5	17.5	15.7	29.8	43.8	24.5	48.2	48.2			
			150	10.3	6.53	14.7	17.5	9.47	19.7	37.2	13.6	29.7	48.2			
			250	17.2	7.68	15.0	17.5	11.1	19.3	33.2	16.2	30.0	48.2			
110 to 300 psig / 7.6 to 20.7 bar  GE42911X012 Orange	150	10.3	200	13.8	7.44	15.7	17.5	10.3	21.4	41.1	15.1	33.4	48.2			
			300	20.7	9.65	17.5	17.5	12.1	21.5	38.5	17.6	35.1	48.2			
			250	17.2	9.44	17.5	17.5	12.5	27.4	43.8	19.0	42.3	48.2			
	200	13.8	300	20.7	11.7	17.5	17.5	15.8	29.4	43.8	23.6	46.5	48.2			
			250	17.2	11.2	17.5	17.5	14.3	32.3	43.8	22.7	48.2	48.2			
			350	24.1	14.1	17.5	17.5	18.3	35.5	43.8	28.4	48.2	48.2			
	250	17.2	350	24.1	14.1	17.5	17.5	18.3	35.5	43.8	28.4	48.2	48.2			
			300	20.7	13.0	17.5	17.5	16.9	38.6	43.8	25.5	48.2	48.2			
			350	24.1	13.0	17.5	17.5	16.9	38.6	43.8	25.5	48.2	48.2			

□ - Spring range is not available for the body size.

- continued -

**Table 10. Typical Water  $C_v$  Coefficient with Quick Opening Cage - Setpoint Made at 10% Flow (for Type MR105 with High-Pressure Actuator) (continued)**

SPRING RANGE, PART NUMBER AND COLOR	SET PRESSURE		INLET PRESSURE		$C_v$ AT % DROOP					
	psig	bar	psig	bar	NPS 3 / DN 80 Body			NPS 4 / DN 100 Body		
					10%	20%	40%	10%	20%	40%
39 to 72 psig / 2.7 to 5.0 bar  GE42909X012 White	40	2.8	75	5.2	16.2	26.6	42.4	19.5	33.1	53.1
			150	10.3	16.6	24.6	36.0	21.7	33.4	47.9
			250	17.2	15.3	20.9	29.6	20.7	28.3	38.0
	50	3.4	75	5.2	17.3	31.2	51.5	23.4	42.5	70.0
			150	10.3	18.6	28.5	43.2	24.4	39.2	56.8
			250	17.2	16.0	23.4	34.8	21.9	31.6	44.7
	60	4.1	75	5.2	18.8	37.1	64.0	26.0	50.1	87.3
			150	10.3	20.5	32.8	50.6	26.6	43.5	65.4
			250	17.2	16.9	26.4	39.6	22.7	34.6	51.0
	70	4.8	100	6.9	20.2	39.2	67.4	26.5	51.4	87.9
			150	10.3	22.7	37.6	59.4	30.2	50.8	78.0
			250	17.2	18.4	29.5	45.3	24.3	39.2	58.4
71 to 175 psig / 4.9 to 12.1 bar  GE42910X012 Silver	75	5.2	100	6.9	18.8	34.8	60.0	24.4	46.0	77.1
			150	10.3	21.8	35.2	55.3	29.1	47.9	71.8
			250	17.2	17.5	28.1	42.8	23.8	38.2	55.8
	100	6.9	150	10.3	20.8	37.8	67.4	26.6	51.1	86.2
			250	17.2	21.1	35.0	55.5	28.2	46.7	71.3
	125	8.6	200	13.8	22.2	41.5	73.1	28.3	55.0	92.2
			300	20.7	22.9	38.2	65.5	30.4	50.8	81.0
	150	10.3	200	13.8	25.2	51.3	92.5	32.7	68.6	118
			300	20.7	26.3	45.7	76.4	35.5	62.7	93.6
	175	12.1	200	13.8	29.6	64.4	103	37.4	83.3	136
			300	20.7	30.1	55.2	90.1	40.0	71.8	114.5
	110 to 250 psig / 7.6 to 17.2 bar  GE42911X012 Orange	125	8.6	150	10.3	21.1	41.8	74.0	26.3	55.1
250				17.2	22.5	37.8	60.1	30.4	49.7	80.5
150		10.3	200	13.8	23.4	44.7	78.4	28.5	56.6	98.4
			300	20.7	24.4	41.4	65.1	31.4	53.3	89.4
200		13.8	250	17.2	26.7	54.8	95.2	32.4	69.4	123
			300	20.7	32.3	57.9	94.7	39.1	73.5	119
250		17.2	300	20.7	28.9	64.2	103.1	36.0	81.6	136
			350	24.1	36.9	67.9	103.1	47.9	92.5	135.9

# Bulletin 71.1:MR105

**Table 11. Typical Air Capacities with Linear Cage - Setpoint Made at 10% Flow (for Type MR105 with Low-Pressure Actuator)**

SPRING RANGE, PART NUMBER AND COLOR	SET PRESSURE		INLET PRESSURE		CAPACITIES IN SCFH / Nm <sup>3</sup> /h OF AIR											
					NPS 1 / DN 25 Body						NPS 2 / DN 50 Body					
			10% Droop		20% Droop		40% Droop		10% Droop		20% Droop		40% Droop			
	psig	bar	psig	bar	SCFH	Nm <sup>3</sup> /h	SCFH	Nm <sup>3</sup> /h	SCFH	Nm <sup>3</sup> /h	SCFH	Nm <sup>3</sup> /h	SCFH	Nm <sup>3</sup> /h	SCFH	Nm <sup>3</sup> /h
5 to 12 psig / 0.34 to 0.83 bar  GE42909X012 White	5	0.34	25	1.7	3300	89	4800	130	9800	260	3800	100	5800	160	11,800	320
			75	5.2	7700	210	12,200	330	25,800	690	10,600	280	13,600	360	27,300	730
			150	10.3	15,500	420	22,200	600	50,000	1300	18,000	480	27,600	740	57,100	1500
			250	17.2	18,400	490	29,100	780	76,400	2000	28,000	750	43,000	1200	93,800	2500
	10	0.69	25	1.7	3100	84	7500	200	17,300	460	5700	150	11,800	320	25,700	690
			75	5.2	12,000	320	23,400	630	41,600	1100	14,000	370	26,200	700	66,100	1800
			150	10.3	20,300	540	38,000	1000	79,700	2100	21,600	580	46,600	1200	121,000	3200
			250	17.2	34,500	930	76,000	2000	128,000	3400	38,800	1000	73,700	2000	182,000	4900
10 to 24 psig / 0.69 to 1.6 bar  GE42910X012 Silver	10	0.69	25	1.7	3100	84	6100	160	13,900	370	4600	120	8000	210	16,600	450
			75	5.2	8600	230	15,300	410	34,200	920	10,200	270	18,300	490	38,500	1000
			150	10.3	15,600	420	28,000	750	64,700	1700	19,700	530	34,200	920	79,300	2100
			250	17.2	29,200	780	46,000	1200	114,000	3100	30,900	830	57,800	1500	127,000	3400
	15	1.0	25	1.7	4000	110	8400	230	16,700	450	5100	140	11,400	310	26,200	700
			75	5.2	11,600	310	22,400	600	43,200	1200	15,200	410	28,200	760	66,600	1800
			150	10.3	21,900	590	43,400	1200	79,100	2100	28,500	760	54,600	1500	123,000	3300
			250	17.2	34,500	920	70,500	1900	128,000	3400	40,400	1100	87,800	2400	192,000	5200
	20	1.4	50	3.4	9800	260	21,900	590	30,600	820	12,500	330	26,000	700	48,200	1300
			75	5.2	13,500	360	29,200	780	42,500	1100	17,100	460	35,900	960	68,000	1800
			150	10.3	26,600	710	61,200	1600	79,400	2100	26,800	720	58,000	1600	125,000	3300
			250	17.2	44,000	1200	90,800	2400	127,000	3400	52,800	1400	121,000	3200	202,000	5400
14 to 32 psig / 0.96 to 2.2 bar  GE42911X012 Orange	15	1.0	25	1.7	3300	87	6400	170	14,700	390	4700	130	8400	230	20,100	540
			75	5.2	8500	230	16,800	450	36,800	990	11,100	300	19,600	520	46,400	1200
			150	10.3	16,000	430	28,900	780	65,100	1700	22,500	600	41,600	1100	90,900	2400
			250	17.2	27,000	720	51,800	1400	120,000	3200	34,500	920	63,200	1700	164,000	4400
	20	1.4	25	1.7	3500	94	7700	210	15,100	400	4300	120	10,400	280	22,700	610
			75	5.2	10,300	280	20,200	540	42,000	1100	13,500	360	26,400	710	66,000	1800
			150	10.3	19,700	530	39,000	1000	77,900	2100	28,600	770	53,700	1400	122,000	3300
			250	17.2	33,500	900	65,300	1700	127,000	3400	38,700	1000	79,800	2100	194,000	5200
	25	1.7	50	3.4	9500	250	18,900	510	29,900	800	10,300	280	22,900	610	47,200	1300
			75	5.2	11,200	300	25,500	680	43,000	1200	14,400	390	35,500	950	67,100	1800
			150	10.3	22,600	610	49,100	1300	79,100	2100	28,900	770	63,400	1700	125,000	3400
			250	17.2	36,400	980	87,500	2300	129,000	3400	42,700	1100	97,300	2600	202,000	5400
	30	2.1	50	3.4	10,000	270	22,000	590	29,700	800	11,100	300	27,300	730	46,400	1200
			75	5.2	14,700	390	33,200	890	42,300	1100	18,600	500	41,900	1100	67,800	1800
			150	10.3	26,700	720	62,100	1700	78,900	2100	34,600	930	80,700	2200	125,000	3300
			250	17.2	49,700	1300	114,000	3100	128,000	3400	47,200	1300	121,000	3300	202,000	5400
18 to 43 psig / 1.2 to 3.0 bar  GE43002X012 Red	20	1.4	50	3.4	5600	150	11,600	310	24,100	640	7800	210	15,700	420	33,200	890
			75	5.2	7800	210	15,500	420	33,600	900	14,000	370	19,900	530	46,300	1200
			150	10.3	16,900	450	30,000	800	66,400	1800	23,200	620	41,300	1100	90,100	2400
			250	17.2	25,400	680	45,200	1200	108,000	2900	36,300	970	62,500	1700	150,000	4000
	25	1.7	50	3.4	6400	170	13,400	360	27,700	740	10,000	270	18,100	490	43,200	1200
			75	5.2	11,000	290	20,700	560	41,600	1100	12,200	330	26,900	720	61,900	1700
			150	10.3	18,000	480	37,600	1000	76,600	2100	26,600	710	49,800	1300	117,000	3100
			250	17.2	31,100	830	59,800	1600	125,000	3300	41,000	1100	78,200	2100	181,000	4900
	30	2.1	50	3.4	8500	230	16,400	440	29,800	800	9100	240	21,600	580	44,900	1200
			75	5.2	12,300	330	24,500	660	42,600	1100	17,100	460	30,100	810	66,400	1800
			150	10.3	22,100	590	46,400	1200	79,200	2100	32,700	880	60,600	1600	122,000	3300
			250	17.2	34,000	910	70,900	1900	125,000	3300	45,000	1200	95,300	2600	198,000	5300
	35	2.4	50	3.4	8400	230	17,900	480	28,600	770	10,600	280	23,600	630	44,700	1200
			75	5.2	13,400	360	26,800	720	42,800	1100	17,800	480	38,300	1000	66,600	1800
			150	10.3	24,800	660	52,600	1400	78,700	2100	34,900	930	71,800	1900	124,000	3300
			250	17.2	39,700	1100	82,200	2200	124,000	3300	50,800	1400	112,000	3000	202,000	5400
	40	2.8	50	3.4	8600	230	19,600	530	27,600	740	10,200	270	26,900	720	43,100	1200
			75	5.2	12,800	340	30,300	810	42,500	1100	20,200	540	42,500	1100	65,500	1800
			150	10.3	25,200	680	61,600	1700	79,700	2100	30,700	820	67,400	1800	125,000	3300
			250	17.2	46,000	1200	99,300	2700	127,000	3400	56,200	1500	133,000	3600	204,000	5500

- continued -

**Table 11. Typical Air Capacities with Linear Cage - Setpoint Made at 10% Flow (for Type MR105 with Low-Pressure Actuator) (continued)**

SPRING RANGE, PART NUMBER AND COLOR	SET PRESSURE		INLET PRESSURE		CAPACITIES IN SCFH / Nm <sup>3</sup> /h OF AIR											
					NPS 3 / DN 80 Body						NPS 4 / DN 100 Body					
					10% Droop		20% Droop		40% Droop		10% Droop		20% Droop		40% Droop	
	psig	bar	psig	bar	SCFH	Nm <sup>3</sup> /h	SCFH	Nm <sup>3</sup> /h	SCFH	Nm <sup>3</sup> /h	SCFH	Nm <sup>3</sup> /h	SCFH	Nm <sup>3</sup> /h	SCFH	Nm <sup>3</sup> /h
5 to 8 psig / 0.34 to 0.55 bar  GE42909X012 White	5	0.34	25	1.7	6300	170	8700	230	15,600	420	6200	160	8600	230	13,300	360
			75	5.2	13,600	360	19,400	520	35,900	960	13,800	370	18,500	500	32,800	880
			150	10.3	23,900	640	35,600	950	61,100	1600	24,000	640	34,300	920	61,000	1600
			250	17.2	34,400	920	50,400	1300	95,900	2600	40,000	1100	54,400	1500	97,000	2600
	8	0.55	25	1.7	8000	210	13,000	350	27,300	730	7000	190	11,000	300	22,800	610
			75	5.2	16,800	450	27,400	730	59,200	1600	16,100	430	25,400	680	51,700	1400
			150	10.3	28,200	750	47,600	1300	103,000	2800	30,100	810	51,400	1400	97,100	2600
			250	17.2	47,700	1300	78,500	2100	174,000	4700	41,500	1100	72,400	1900	156,000	4200
8 to 20 psig / 0.55 to 1.4 bar  GE42910X012 Silver	10	0.69	25	1.7	6600	180	11,200	300	22,000	590	5000	130	9600	260	19,300	520
			75	5.2	17,000	450	25,800	690	50,800	1400	14,600	390	22,500	600	46,600	1200
			150	10.3	28,500	760	43,500	1200	91,000	2400	25,900	690	39,300	1100	78,100	2100
			250	17.2	44,900	1200	72,300	1900	151,000	4000	37,700	1000	61,000	1600	127,000	3400
	15	1.0	25	1.7	7700	210	15,000	400	34,800	930	6400	170	12,700	340	29,400	790
			75	5.2	20,700	560	37,800	1000	85,400	2300	18,600	500	32,500	870	71,700	1900
			150	10.3	34,100	910	64,300	1700	151,000	4000	30,900	830	56,100	1500	130,000	3500
			250	17.2	57,900	1600	106,000	2900	240,000	6400	48,100	1300	88,700	2400	210,000	5600
	20	1.4	50	3.4	13,300	360	28,300	760	64,000	1700	15,200	410	29,200	780	55,100	1500
			75	5.2	25,000	670	49,300	1300	91,000	2400	23,600	630	42,700	1100	76,100	2000
			150	10.3	44,200	1200	90,300	2400	168,000	4500	38,000	1000	74,000	2000	154,000	4100
			250	17.2	72,900	2000	145,000	3900	271,000	7300	72,800	2000	121,000	3200	250,000	6700
12 to 30 psig / 0.83 to 2.1 bar  GE42911X012 Orange	15	1.0	25	1.7	6400	170	11,300	300	24,500	660	5300	140	9000	240	20,900	560
			75	5.2	16,700	450	27,000	720	58,400	1600	15,400	410	24,900	670	50,200	1300
			150	10.3	29,100	780	49,200	1300	105,000	2800	28,900	770	47,000	1300	97,000	2600
			250	17.2	47,800	1300	78,900	2100	173,000	4600	46,000	1200	75,400	2000	157,000	4200
	20	1.4	25	1.7	7200	190	14,100	380	31,700	850	4700	130	10,100	270	26,100	700
			75	5.2	19,600	520	35,300	940	81,300	2200	20,000	530	34,200	920	75,400	2000
			150	10.3	34,300	920	61,600	1700	149,000	4000	35,100	940	61,400	1600	138,000	3700
			250	17.2	49,600	1300	94,200	2500	234,000	6300	48,900	1300	87,200	2300	207,000	5600
	25	1.7	50	3.4	18,400	490	32,000	860	63,900	1700	13,800	370	26,600	710	54,300	1500
			75	5.2	21,400	570	42,600	1100	90,200	2400	19,900	530	40,500	1100	77,300	2100
			150	10.3	31,500	840	66,900	1800	166,000	4400	38,300	1000	73,600	2000	143,000	3800
			250	17.2	71,900	1900	138,000	3700	267,000	7200	57,400	1500	112,000	3000	232,000	6200
30	2.1	50	3.4	18,900	510	33,800	910	64,600	1700	14,600	390	32,600	870	52,900	1400	
		75	5.2	29,700	800	56,800	1500	89,800	2400	24,500	660	50,300	1300	76,800	2100	
		150	10.3	45,600	1200	90,500	2400	167,000	4500	44,900	1200	91,200	2400	143,000	3800	
		250	17.2	72,700	1900	158,000	4200	269,000	7200	71,700	1900	145,000	3900	231,000	6200	
18 to 39 psig / 1.2 to 2.7 bar  GE43002X012 Red	20	1.4	50	3.4	12,000	320	20,100	540	42,600	1100	9800	260	17,000	460	36,300	970
			75	5.2	16,900	450	27,600	740	60,300	1600	15,100	400	26,100	700	51,600	1400
			150	10.3	29,500	790	48,800	1300	107,000	2900	28,300	760	46,700	1300	96,600	2600
			250	17.2	51,100	1400	83,200	2200	177,000	4700	48,300	1300	78,200	2100	164,000	4400
	25	1.7	50	3.4	14,400	390	25,700	690	55,100	1500	12,200	330	21,400	570	48,900	1300
			75	5.2	20,000	540	35,400	950	79,300	2100	18,300	490	31,600	850	68,800	1800
			150	10.3	28,400	760	51,700	1400	125,000	3300	34,100	910	58,300	1600	132,000	3500
			250	17.2	57,100	1500	100,000	2700	232,000	6200	51,600	1400	93,000	2500	214,000	5700
	30	2.1	50	3.4	12,400	330	25,500	680	62,800	1700	12,400	330	23,900	640	54,400	1500
			75	5.2	23,100	620	42,300	1100	88,300	2400	19,700	530	36,500	980	79,500	2100
			150	10.3	38,200	1000	73,500	2000	160,000	4300	36,700	980	68,900	1800	145,000	3900
			250	17.2	62,900	1700	117,000	3100	265,000	7100	62,600	1700	114,000	3100	244,000	6500
35	2.4	50	3.4	18,700	500	32,700	880	63,000	1700	13,400	360	27,100	730	54,300	1500	
		75	5.2	20,800	560	42,500	1100	90,300	2400	23,200	620	45,000	1200	79,900	2100	
		150	10.3	38,000	1000	78,400	2100	167,000	4500	41,100	1100	81,000	2200	151,000	4000	
		250	17.2	68,400	1800	139,000	3700	270,000	7200	66,000	1800	137,000	3700	244,000	6500	





**Table 12. Typical Air Capacities with Linear Cage - Setpoint Made at 10% Flow (for Type MR105 with High-Pressure Actuator) (continued)**

SPRING RANGE, PART NUMBER AND COLOR	SET PRESSURE		INLET PRESSURE		CAPACITIES IN SCFH / Nm <sup>3</sup> /h OF AIR											
					NPS 3 / DN 80 Body						NPS 4 / DN 100 Body					
					10% Droop		20% Droop		40% Droop		10% Droop		20% Droop		40% Droop	
	psig	bar	psig	bar	SCFH	Nm <sup>3</sup> /h	SCFH	Nm <sup>3</sup> /h	SCFH	Nm <sup>3</sup> /h	SCFH	Nm <sup>3</sup> /h	SCFH	Nm <sup>3</sup> /h	SCFH	Nm <sup>3</sup> /h
39 to 72 psig / 2.7 to 5.0 bar  GE42909X012 White	40	2.8	75	5.2	9900	270	13,900	370	23,100	620	11,200	300	14,500	390	23,200	620
			150	10.3	21,600	580	29,400	790	47,800	1300	20,200	540	26,300	710	43,000	1200
			250	17.2	33,500	900	45,300	1200	73,600	2000	33,600	900	44,000	1200	69,900	1900
	50	3.4	75	5.2	10,300	280	14,700	390	28,400	760	9600	260	13,700	370	26,000	700
			150	10.3	21,100	560	29,600	790	54,100	1500	22,300	600	31,300	840	53,100	1400
			250	17.2	33,700	900	47,700	1300	84,500	2300	35,700	960	48,400	1300	83,600	2200
	60	4.1	75	5.2	9900	270	16,800	450	34,300	920	9600	260	15,400	410	30,900	830
			150	10.3	21,200	570	32,600	870	63,800	1700	22,400	600	33,600	900	60,900	1600
			250	17.2	39,400	1100	56,500	1500	107,000	2900	37,900	1000	53,800	1400	100,000	2700
	70	4.8	100	6.9	13,900	370	23,500	630	51,300	1400	14,300	380	22,700	610	47,500	1300
			150	10.3	23,900	640	38,000	1000	75,600	2000	24,800	660	36,500	980	70,900	1900
			250	17.2	39,100	1000	59,800	1600	122,000	3300	40,000	1100	60,700	1600	119,000	3200
71 to 175 psig / 4.9 to 12.1 bar  GE42910X012 Silver	75	5.2	100	6.9	13,200	350	20,800	560	41,100	1100	12,600	340	18,900	510	36,600	980
			150	10.3	23,700	640	34,800	930	63,700	1700	23,000	620	31,300	840	58,400	1600
			250	17.2	37,300	1000	53,900	1400	95,400	2600	37,300	1000	50,900	1400	93,000	2500
	100	6.9	150	10.3	17,300	460	31,700	850	71,200	1900	22,500	600	35,200	940	71,200	1900
			250	17.2	41,000	1100	64,200	1700	126,000	3400	40,000	1100	60,900	1600	116,000	3100
			200	13.8	35,900	960	61,200	1600	136,000	3600	32,100	860	54,500	1500	119,000	3200
	125	8.6	300	20.7	54,900	1500	90,300	2400	192,000	5200	49,800	1300	84,700	2300	179,000	4800
			200	13.8	34,800	930	65,900	1800	161,000	4300	32,200	860	61,100	1600	145,000	3900
			300	20.7	59,600	1600	105,000	2800	234,000	6300	61,100	1600	102,000	2700	225,000	6000
	150	10.3	200	13.8	25,000	670	57,700	1500	175,000	4700	29,700	800	63,400	1700	165,000	4400
			300	20.7	67,400	1800	124,000	3300	292,000	7800	60,500	1600	113,000	3000	258,000	6900
			200	13.8	34,800	930	65,900	1800	161,000	4300	32,200	860	61,100	1600	145,000	3900
110 to 250 psig / 7.6 to 17.2 bar  GE42911X012 Orange	125	8.6	150	10.3	18,300	490	32,500	870	73,600	2000	11,900	320	15,100	400	52,300	1400
			250	17.2	38,600	1000	58,400	1600	117,000	3100	31,600	850	39,700	1100	113,000	3000
	150	10.3	200	13.8	30,400	820	52,800	1400	119,000	3200	26,600	710	43,700	1200	97,000	2600
			300	20.7	42,000	1100	72,100	1900	157,000	4200	50,900	1400	80,100	2100	164,000	4400
	200	13.8	250	17.2	45,300	1200	85,000	2300	205,000	5500	36,500	980	69,200	1900	170,000	4600
			300	20.7	64,400	1700	112,000	3000	257,000	6900	57,800	1500	102,000	2700	227,000	6100
	250	17.2	300	20.7	61,300	1600	121,000	3200	293,000	7900	51,200	1400	108,000	2900	264,000	7100
			350	24.1	88,900	2400	168,000	4500	347,000	9300	80,600	2200	155,000	4200	319,000	8500

# Bulletin 71.1:MR105

**Table 13. Typical Water Capacities with Quick Opening Cage - Setpoint Made at 10% Flow (for Type MR105 with Low-Pressure Actuator)**

SPRING RANGE, PART NUMBER AND COLOR	SET PRESSURE		INLET PRESSURE		CAPACITIES IN GPM / LPM OF WATER																	
					NPS 1 / DN 25 Body						NPS 2 / DN 50 - Reduced Port				NPS 2 / DN 50 Body							
	psig	bar	psig	bar	10% Droop		20% Droop		40% Droop		10% Droop		20% Droop		40% Droop		10% Droop		20% Droop		40% Droop	
					GPM	LPM	GPM	LPM	GPM	LPM	GPM	LPM	GPM	LPM	GPM	LPM	GPM	LPM	GPM	LPM	GPM	LPM
5 to 12 psig / 0.34 to 0.83 bar  GE42909X012 White	5	0.34	25	1.7	24	91	44	170	72	270	37	140	58	220	100	380	54	200	92	350	160	610
			75	5.2	42	160	79	300	130	500	74	280	110	410	160	620	92	350	160	610	250	950
			150	10.3	52	200	110	400	180	690	99	370	140	510	190	720	130	500	210	780	350	1310
	10	0.69	25	1.7	35	130	61	230	84	320	50	190	83	310	160	600	73	280	130	510	220	840
			75	5.2	74	280	130	490	160	590	99	370	150	570	260	990	150	550	230	870	390	1460
			150	10.3	110	410	180	680	210	790	140	520	180	690	320	1210	200	740	290	1080	470	1790
10 to 24 psig / 0.69 to 1.6 bar  GE42910X012 Silver	10	0.69	25	1.7	29	110	52	200	80	300	40	150	67	250	120	460	61	230	110	400	180	700
			75	5.2	53	200	100	390	150	560	84	320	130	480	210	790	120	450	190	710	310	1150
			150	10.3	77	290	160	590	200	770	110	420	160	600	260	980	170	640	260	970	390	1470
	15	1.0	25	1.7	37	140	65	250	89	340	46	170	86	330	160	590	71	270	130	500	210	790
			75	5.2	65	250	110	430	150	550	110	420	190	710	300	1150	140	540	240	900	380	1430
			150	10.3	96	360	180	670	210	780	140	530	210	800	360	1360	200	760	320	1230	580	2200
	20	1.4	50	3.4	56	210	95	360	110	430	84	320	150	580	260	1000	130	500	230	850	350	1310
			75	5.2	81	310	130	500	150	560	120	450	200	750	330	1260	170	640	290	1090	430	1630
			150	10.3	130	500	200	740	210	790	160	590	270	1000	450	1700	220	850	390	1480	700	2660
14 to 32 psig / 0.96 to 2.2 bar  GE42911X012 Orange	15	1.0	25	1.7	24	91	46	170	74	280	36	140	61	230	120	450	53	200	100	380	180	690
			75	5.2	60	230	110	400	150	560	88	330	140	510	240	890	120	470	200	770	340	1290
			150	10.3	82	310	150	580	200	770	120	470	180	670	300	1120	170	650	280	1070	490	1860
	20	1.4	25	1.7	24	91	45	170	64	240	37	140	73	280	140	520	53	200	110	420	190	710
			75	5.2	75	280	120	440	140	530	110	410	180	700	300	1130	150	570	270	1030	410	1560
			150	10.3	110	410	180	670	210	790	140	530	220	820	380	1430	220	840	400	1500	610	2310
	25	1.7	50	3.4	50	190	83	310	110	400	87	330	160	590	240	920	130	480	220	840	320	1200
			75	5.2	90	340	120	450	140	530	120	450	210	800	320	1200	160	610	270	1040	420	1570
			150	10.3	110	420	190	700	210	790	160	600	260	980	450	1700	230	870	410	1530	620	2350
	30	2.1	50	3.4	56	210	90	340	110	410	80	300	150	560	240	920	120	450	210	810	330	1260
			75	5.2	82	310	130	480	140	530	120	460	210	800	330	1230	160	620	290	1110	440	1650
			150	10.3	130	500	200	750	210	790	170	650	290	1110	480	1830	240	920	410	1540	700	2660
18 to 43 psig / 1.2 to 3.0 bar  GE43002X012 Red	20	1.4	50	3.4	39	150	73	280	110	420	61	230	100	390	180	700	90	340	150	570	270	1010
			75	5.2	57	220	100	380	140	540	85	320	130	500	240	890	120	450	200	750	330	1260
			150	10.3	79	300	150	560	200	760	130	480	190	710	310	1160	180	680	290	1100	470	1770
	25	1.7	50	3.4	46	170	77	290	110	400	67	250	120	460	220	830	100	380	190	700	300	1130
			75	5.2	60	230	110	410	150	580	98	370	160	600	280	1050	140	520	230	880	390	1470
			150	10.3	100	380	170	650	210	790	140	510	200	750	340	1290	210	780	330	1250	550	2060
	30	2.1	50	3.4	47	180	76	290	100	380	69	260	130	490	230	850	110	410	200	760	300	1150
			75	5.2	66	250	110	420	150	580	100	390	170	650	290	1100	140	540	240	920	380	1450
			150	10.3	120	440	180	690	210	790	140	540	230	850	400	1510	220	810	380	1450	580	2200
	35	2.4	50	3.4	44	170	74	280	95	360	73	280	130	500	230	850	110	410	200	770	290	1100
			75	5.2	68	260	110	420	140	550	110	420	190	710	300	1140	160	590	270	1020	400	1500
			150	10.3	130	470	190	710	210	790	150	580	260	970	450	1690	240	900	400	1500	610	2300
40	2.8	50	3.4	40	150	71	270	96	360	65	250	130	490	220	830	94	360	170	660	290	1110	
		75	5.2	70	260	110	430	140	510	120	450	200	750	310	1160	160	600	280	1040	420	1570	
		150	10.3	130	490	190	720	210	780	170	630	290	1090	480	1810	260	980	430	1610	630	2370	

- continued -

**Table 13. Typical Water Capacities with Quick Opening Cage - Setpoint Made at 10% Flow (for Type MR105 with Low-Pressure Actuator) (continued)**

SPRING RANGE, PART NUMBER AND COLOR	SET PRESSURE		INLET PRESSURE		CAPACITIES IN GPM / LPM OF WATER											
					NPS 3 / DN 80 Body						NPS 4 / DN 100 Body					
	psig	bar	psig	bar	10% Droop		20% Droop		40% Droop		10% Droop		20% Droop		40% Droop	
					GPM	LPM	GPM	LPM	GPM	LPM	GPM	LPM	GPM	LPM	GPM	LPM
5 to 8 psig / 0.34 to 0.55 bar  GE42909X012 White	5	0.34	25	1.7	87	330	130	480	220	830	110	420	170	640	290	1100
			75	5.2	140	540	200	770	320	1190	190	720	270	1030	440	1650
			150	10.3	190	730	240	900	390	1480	260	1000	360	1350	510	1920
	8	0.55	25	1.7	99	370	170	640	300	1140	120	460	230	880	410	1550
			75	5.2	180	670	260	1000	450	1680	240	900	360	1380	610	2310
			150	10.3	220	840	300	1150	520	1980	300	1120	460	1720	720	2740
8 to 20 psig / 0.55 to 1.4 bar  GE42910X012 Silver	10	0.69	25	1.7	90	340	150	560	270	1010	120	450	190	730	350	1320
			75	5.2	170	640	250	950	450	1680	230	880	350	1320	590	2220
			150	10.3	230	860	330	1230	540	2040	300	1150	440	1660	730	2750
	15	1.0	25	1.7	100	380	180	690	340	1300	130	470	230	890	460	1740
			75	5.2	220	820	350	1320	590	2220	260	1000	470	1790	830	3150
			150	10.3	260	980	420	1570	740	2790	380	1440	580	2210	1000	3770
	20	1.4	50	3.4	190	700	340	1280	590	2210	230	870	440	1680	780	2960
			75	5.2	230	870	420	1600	710	2680	300	1150	560	2100	970	3660
			150	10.3	320	1190	520	1950	920	3470	420	1580	680	2590	1250	4740
12 to 30 psig / 0.83 to 2.1 bar  GE42911X012 Orange	15	1.0	25	1.7	86	330	150	560	280	1070	100	390	180	700	360	1370
			75	5.2	190	700	290	1090	500	1900	220	840	370	1390	640	2410
			150	10.3	240	910	370	1390	630	2400	320	1210	510	1920	830	3140
	20	1.4	25	1.7	81	310	160	600	320	1220	100	390	200	760	420	1570
			75	5.2	210	800	360	1360	630	2370	260	990	440	1650	810	3070
			150	10.3	270	1000	440	1650	780	2960	390	1460	610	2310	1020	3850
	25	1.7	50	3.4	170	650	310	1160	560	2110	230	850	400	1510	750	2840
			75	5.2	240	890	420	1570	720	2730	290	1090	510	1930	920	3490
			150	10.3	320	1220	540	2040	920	3460	430	1620	710	2680	1220	4630
	30	2.1	250	17.2	380	1450	610	2320	1050	3960	500	1880	790	2970	1380	5210
			50	3.4	180	690	340	1280	580	2200	230	860	430	1640	720	2730
			75	5.2	270	1010	460	1750	750	2840	320	1220	580	2180	960	3630
30	2.1	150	10.3	360	1360	620	2340	1020	3850	480	1810	810	3070	1330	5050	
		250	17.2	420	1580	680	2590	1100	4170	560	2130	930	3520	1590	6000	
		50	3.4	140	530	230	860	410	1540	170	650	280	1040	520	1970	
18 to 39 psig / 1.2 to 2.7 bar  GE43002X012 Red	20	1.4	75	5.2	180	690	290	1090	510	1950	220	850	370	1380	650	2460
			150	10.3	240	920	380	1440	650	2480	320	1200	490	1850	860	3240
			50	3.4	150	560	260	970	490	1850	190	720	310	1180	590	2230
	25	1.7	75	5.2	210	810	340	1290	610	2290	240	900	420	1590	760	2870
			150	10.3	270	1010	450	1690	780	2960	360	1370	590	2220	1010	3800
			250	17.2	340	1280	520	1980	870	3300	440	1670	690	2610	1170	4440
	30	2.1	50	3.4	150	580	270	1030	520	1960	190	700	340	1280	660	2510
			75	5.2	230	850	390	1460	680	2570	260	980	460	1760	860	3240
			150	10.3	310	1150	530	2000	910	3430	390	1480	670	2530	1150	4350
	30	2.1	250	17.2	360	1370	590	2230	1030	3910	480	1810	770	2930	1360	5140
			50	3.4	160	590	290	1090	550	2090	180	700	360	1370	690	2620
			75	5.2	240	920	430	1620	730	2750	270	1030	500	1880	920	3470
	35	2.4	150	10.3	340	1280	590	2210	1000	3770	420	1590	740	2810	1280	4860
			250	17.2	410	1540	670	2550	1150	4340	550	2070	900	3390	1540	5840

# Bulletin 71.1:MR105

**Table 14.** Typical Water Capacities with Quick Opening Cage - Setpoint Made at 10% Flow (for Type MR105 with High-Pressure Actuator)

SPRING RANGE, PART NUMBER AND COLOR	SET PRESSURE		INLET PRESSURE		CAPACITIES IN GPM / LPM OF WATER																	
					NPS 1 / DN 25 Body						NPS 2 / DN 50 - Reduced Port				NPS 2 / DN 50 Body							
					10% Droop		20% Droop		40% Droop		10% Droop		20% Droop		40% Droop		10% Droop		20% Droop		40% Droop	
					GPM	LPM	GPM	LPM	GPM	LPM	GPM	LPM	GPM	LPM	GPM	LPM	GPM	LPM	GPM	LPM	GPM	LPM
25 to 60 psig / 1.7 to 4.1 bar GE42907X012 Green	25	1.7	50	3.4	23	87	41	160	76	290												
			75	5.2	35	130	61	230	110	410												
			150	10.3	55	210	120	450	190	700												
			250	17.2	60	230	250	930	260	970												
	30	2.1	50	3.4	23	87	43	160	79	300												
			75	5.2	37	140	67	250	110	420												
			150	10.3	62	230	140	530	190	710												
	40	2.8	50	3.4	22	83	44	170	79	300												
			75	5.2	44	170	77	290	120	440												
			150	10.3	82	310	160	610	190	720												
	50	3.4	50	3.4	22	83	44	170	79	300												
			75	5.2	40	150	75	280	110	420												
150			10.3	94	360	160	610	190	700													
60	4.1	50	3.4	22	83	44	170	79	300													
		75	5.2	37	140	70	260	110	410													
		150	10.3	110	400	160	610	190	700													

25 to 45 psig / 1.7 to 3.1 bar GE42907X012 Green	25	1.7	50	3.4						38	140	57	220	96	360	51	190	76	290	140	540	
			75	5.2							59	220	83	310	130	490	81	310	120	440	190	700
			150	10.3							83	310	120	440	180	670	120	440	160	610	250	960
	30	2.1	50	3.4						35	130	57	220	110	400	49	190	81	310	150	580	
			75	5.2						60	230	88	330	150	560	85	320	130	480	210	790	
			150	10.3						83	310	120	470	210	780	120	460	180	690	300	1130	
	40	2.8	50	3.4						33	120	59	220	120	460	50	190	92	350	180	700	
			75	5.2						68	260	100	390	180	690	96	360	150	570	270	1010	
			150	10.3						93	350	150	550	250	960	150	560	220	840	390	1470	
	45	3.1	75	5.2						51	190	89	340	180	660	77	290	130	510	260	990	
			150	10.3						97	370	150	570	280	1070	130	500	230	880	410	1560	

43 to 100 psig / 3.0 to 6.9 bar GE42909X012 White	50	3.4	75	5.2	33	120	61	230	110	400	46	170	78	300	150	580	65	250	120	440	230	860
			150	10.3	69	260	130	480	180	680	90	340	140	530	250	940	130	510	220	820	390	1480
			250	17.2	120	440	230	860	250	940	120	460	180	680	300	1150	170	650	260	1000	490	1840
	60	4.1	75	5.2	31	120	59	220	100	380	44	170	78	300	160	620	62	230	120	440	240	910
			150	10.3	76	290	140	520	180	670	96	360	150	570	280	1060	150	570	250	930	460	1730
			250	17.2	120	440	230	860	240	920	130	470	200	740	340	1290	200	740	320	1230	600	2260
	75	5.2	100	6.9	45	170	83	310	120	470	56	210	110	400	220	850	87	330	170	630	330	1260
			250	17.2	170	640	230	860	240	910	140	520	220	830	400	1530	210	790	360	1370	670	2550
			150	10.3	78	300	130	490	160	600	92	350	170	650	350	1310	130	500	270	1020	490	1850
	100	6.9	250	17.2	160	620	210	810	230	890	170	620	270	1010	510	1910	240	920	460	1720	690	2590

75 to 175 psig / 5.2 to 12.1 bar GE42910X012 Silver	75	5.2	100	6.9	33	120	64	240	110	430	46	170	81	310	170	640	68	260	130	470	260	970
			250	17.2	84	320	170	640	240	890	120	470	190	720	330	1230	170	640	270	1020	520	1950
	100	6.9	150	10.3	56	210	110	400	160	600	72	270	130	490	270	1020	110	430	210	780	410	1540
			250	17.2	110	410	190	720	230	880	140	530	220	840	400	1510	200	750	320	1210	620	2340
			200	13.8	81	310	150	550	190	710	100	390	190	710	370	1390	160	590	290	1080	550	2090
	125	8.6	300	20.7	150	560	230	860	250	950	170	630	270	1030	500	1910	230	870	440	1650	700	2630
			200	13.8	80	300	140	510	180	680	100	390	190	730	400	1510	150	580	290	1110	550	2070
			300	20.7	150	580	220	830	240	920	190	700	300	1140	580	2180	280	1060	500	1890	700	2630
	150	10.3	200	13.8	69	260	120	470	170	620	94	360	200	740	420	1590	140	520	280	1070	540	2050
			300	20.7	150	560	210	780	240	890	190	710	320	1210	600	2280	290	1110	520	1970	700	2630

110 to 300 psig / 7.6 to 20.7 bar GE42911X012 Orange	125	8.6	150	10.3	40	150	81	310	140	540	58	220	110	410	240	890	83	310	160	620	360	1360
			250	17.2	90	340	160	600	220	830	130	490	200	770	370	1390	190	720	320	1200	580	2180
	150	10.3	200	13.8	60	230	110	430	170	650	83	310	160	590	330	1250	120	460	240	920	490	1850
			300	20.7	120	470	200	760	240	920	160	590	250	940	470	1760	230	860	410	1530	690	2600
	200	13.8	250	17.2	79	300	140	540	190	720	110	400	210	780	430	1640	160	600	320	1200	600	2270
			300	20.7	130	480	190	710	230	860	170	650	290	1100	550	2070	260	980	460	1730	690	2620
	250	17.2	300	20.7	97	370	160	600	210	780	120	470	250	950	530	1990	200	750	400	1510	650	2480
			350	24.1	160	600	200	770	220	830	210	780	360	1350	580	2200	320	1200	530	2020	630	2380
	300	20.7	350	24.1	120	440	170	660	190	730	150	570	310	1170	540	2040	230	860	480	1830	630	2390

□ - Spring range is not available for the body size.

- continued -

**Table 14. Typical Water Capacities with Quick Opening Cage - Setpoint Made at 10% Flow (for Type MR105 with High-Pressure Actuator) (continued)**

SPRING RANGE, PART NUMBER AND COLOR	SET PRESSURE		INLET PRESSURE		CAPACITIES IN GPM / LPM OF WATER											
					NPS 3 / DN 80 Body						NPS 4 / DN 100 Body					
					10% Droop		20% Droop		40% Droop		10% Droop		20% Droop		40% Droop	
	psig	bar	psig	bar	GPM	LPM	GPM	LPM	GPM	LPM	GPM	LPM	GPM	LPM	GPM	LPM
39 to 72 psig / 2.7 to 5.0 bar  GE42909X012 White	40	2.8	75	5.2	100	380	140	550	240	910	120	460	180	660	300	1120
			150	10.3	180	670	230	860	340	1290	230	880	300	1150	440	1670
			250	17.2	220	820	270	1010	380	1440	290	1080	350	1330	480	1810
	50	3.4	75	5.2	95	360	150	560	260	1000	130	480	200	750	350	1330
			150	10.3	190	720	250	960	390	1490	250	950	340	1290	510	1920
			250	17.2	230	860	290	1100	440	1660	300	1140	380	1450	550	2080
	60	4.1	75	5.2	86	330	150	560	290	1090	120	450	190	730	380	1450
			150	10.3	200	760	280	1060	440	1680	260	990	360	1370	560	2120
			250	17.2	240	890	320	1210	490	1850	310	1180	410	1560	620	2330
	70	4.8	100	6.9	120	470	210	780	390	1470	160	610	270	1000	490	1870
			150	10.3	210	800	310	1150	500	1890	280	1070	400	1520	640	2430
			250	17.2	250	950	350	1330	550	2080	330	1260	460	1720	690	2620
71 to 175 psig / 4.9 to 12.1 bar  GE42910X012 Silver	75	5.2	100	6.9	110	400	170	650	330	1250	140	530	220	840	410	1560
			150	10.3	200	750	280	1050	460	1730	260	1000	370	1400	580	2190
			250	17.2	240	900	330	1250	510	1940	320	1220	440	1660	650	2470
	100	6.9	150	10.3	160	610	250	960	490	1850	210	780	340	1270	610	2320
			250	17.2	270	1010	390	1460	630	2380	360	1350	500	1900	790	2990
	125	8.6	200	13.8	210	790	340	1280	640	2400	270	1000	440	1650	780	2960
			300	20.7	310	1180	460	1720	810	3050	420	1570	590	2240	970	3680
	150	10.3	200	13.8	200	770	360	1360	720	2720	260	1000	470	1780	900	3400
			300	20.7	340	1280	510	1930	890	3370	460	1730	680	2590	1070	4040
	175	12.1	200	13.8	190	730	360	1380	770	2900	240	920	460	1740	960	3620
			300	20.7	360	1360	570	2170	990	3750	480	1810	730	2760	1230	4660
	110 to 250 psig / 7.6 to 17.2 bar  GE42911X012 Orange	125	8.6	150	10.3	130	490	220	840	450	1720	160	610	290	1080	570
250				17.2	260	1000	390	1460	640	2420	360	1350	500	1870	840	3170
150		10.3	200	13.8	190	720	310	1180	610	2310	230	870	390	1460	750	2830
			300	20.7	310	1180	460	1750	760	2870	400	1530	580	2200	1020	3860
200		13.8	250	17.2	220	840	400	1510	790	2970	270	1030	490	1870	990	3760
			300	20.7	350	1340	550	2090	970	3690	430	1620	680	2590	1200	4540
250		17.2	300	20.7	250	950	480	1830	960	3640	310	1180	600	2270	1250	4720
			350	24.1	410	1560	660	2500	1170	4410	540	2020	880	3320	1650	6240

# Bulletin 71.1:MR105

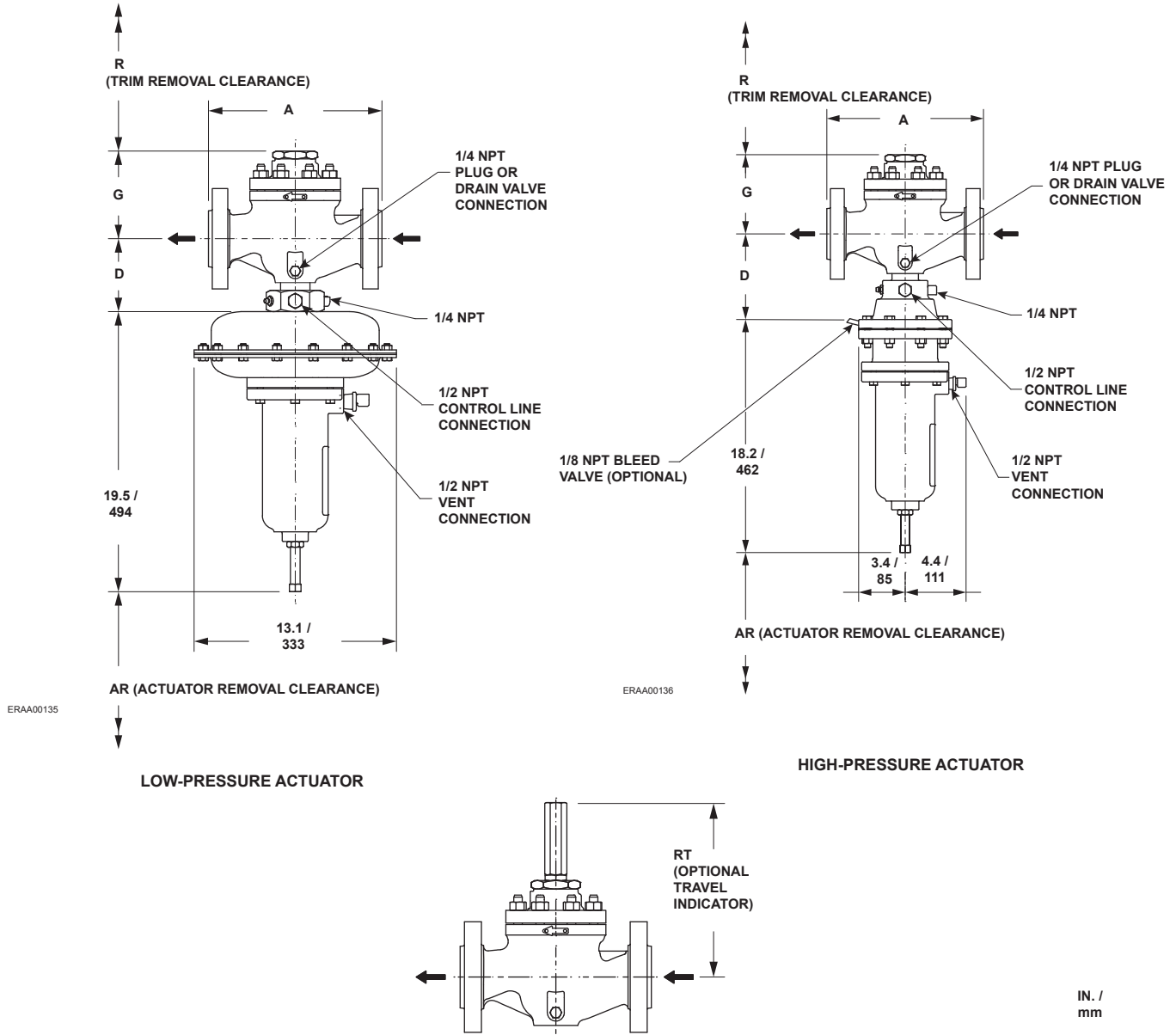

Figure 5. Type MR105 Dimensions

Table 15. Type MR105 Dimensions

BODY SIZE		DIMENSION, in. / mm										
		A					AR	D		G	R	RT
		NPT	CL125 FF/ CL150 RF	CL250 RF/ CL300 RF	CL600 RF	PN 16/25/40 RF		Low- Pressure Actuator	High- Pressure Actuator			
NPS	DN											
1	25	8.25 / 210	7.25 / 184	7.75 / 197	8.25 / 210	7.62 / 194	3.2 / 82	4.1 / 105	5.5 / 140	5.2 / 133	3.4 / 87	9.8 / 249
2	50	11.25 / 286	10.0 / 254	10.50 / 267	11.25 / 286	10.25 / 260	3.7 / 94	4.8 / 122	6.2 / 158	5.7 / 145	4.1 / 105	10.3 / 262
3	80	----	11.75 / 299	12.50 / 318	13.25 / 337	12.48 / 317	4.5 / 115	5.4 / 138	6.8 / 173	7.0 / 178	5.2 / 133	11.6 / 295
4	100	----	13.88 / 353	14.50 / 368	15.50 / 394	13.78 / 350	5.7 / 145	6.7 / 171	8.1 / 206	8.4 / 214	6.4 / 163	13.0 / 331



## Ordering Information

Use the Specifications section on page 2 and carefully review the description to the right of each specification. Use this information to complete the

Ordering Guide below. Specify the desired selection wherever there is a choice to be made. Then send the Ordering Guide to your local Sales Office.

## Ordering Guide

### Body Size (Select One)

- NPS 1 / DN 25
- NPS 2 / DN 50
- NPS 3 / DN 80
- NPS 4 / DN 100

### Actuator Type (Select One)

- Low Pressure
- High Pressure

### Cage Type (Select One)

- Linear (For Gas Service Only)
- Quick Open (For Liquid Service Only)

### Body Material and End Connection Style (Select One)

#### Cast Iron

- NPT (1 or 2 NPT only)
- CL125 FF
- CL250 RF

#### WCC Steel

- NPT (1 or 2 NPT only)
- CL150 RF
- CL300 RF
- CL600 RF
- PN 16 RF
- PN 16/25/40 RF (NPS 1 or 2 / DN 25 or 50 only)

#### CF8M Stainless Steel

- NPT (1 or 2 NPT only)
- CL150 RF
- CL300 RF
- CL600 RF
- PN 16 RF
- PN 16/25/40 RF (NPS 1 or 2 / DN 25 or 50 only)

#### CF3M Stainless Steel

- NPT (1 or 2 NPT only)
- CL150 RF
- CL300 RF
- CL600 RF
- PN 16 RF
- PN 16/25/40 RF (NPS 1 or 2 / DN 25 or 50 only)

### Diaphragm, O-rings and Seal Materials (Select One)

- Nitrile (NBR)
- Fluorocarbon (FKM)
- Ethylene Propylene (EPDM)

### Actuator Type and Outlet Pressure Range (Select One)

#### NPS 1 / DN 25

##### Low-Pressure Actuator

- 5 to 12 psig / 0.34 to 0.83 bar, White
- 10 to 24 psig / 0.69 to 1.6 bar, Silver
- 14 to 32 psig / 0.96 to 2.2 bar, Orange
- 18 to 43 psig / 1.2 to 3.0 bar, Red

##### High-Pressure Actuator

- 25 to 60 psig / 1.7 to 4.1 bar, Green
- 43 to 100 psig / 3.0 to 6.9 bar, White
- 75 to 175 psig / 5.2 to 12.1 bar, Silver<sup>(1)</sup>
- 110 to 300 psig / 7.6 to 20.7 bar, Orange<sup>(1)</sup>

#### NPS 2 / DN 50

##### Low-Pressure Actuator

- 5 to 12 psig / 0.34 to 0.83 bar, White
- 10 to 24 psig / 0.69 to 1.6 bar, Silver
- 14 to 32 psig / 0.96 to 2.2 bar, Orange
- 18 to 43 psig / 1.2 to 3.0 bar, Red

##### High-Pressure Actuator

- 25 to 45 psig / 1.7 to 3.1 bar, Green
- 43 to 100 psig / 3.0 to 6.9 bar, White
- 75 to 175 psig / 5.2 to 12.1 bar, Silver<sup>(1)</sup>
- 110 to 300 psig / 7.6 to 20.7 bar, Orange<sup>(1)</sup>

#### NPS 3 and 4 / DN 80 and 100

##### Low-Pressure Actuator

- 5 to 8 psig / 0.34 to 0.55 bar, White
- 8 to 20 psig / 0.55 to 1.4 bar, Silver
- 12 to 30 psig / 0.83 to 2.1 bar, Orange
- 18 to 39 psig / 1.2 to 2.7 bar, Red

##### High-Pressure Actuator

- 39 to 72 psig / 2.7 to 5.0 bar, White
- 71 to 175 psig / 4.9 to 12.1 bar, Silver<sup>(1)</sup>
- 110 to 250 psig / 7.6 to 17.2 bar, Orange<sup>(1)</sup>

### Optional

- Visual Travel Indicator
- Drain Valve
- Pressure-Loaded Actuator
- NACE Construction
- Bleed Valve (for High-Pressure Actuator Only)

- continued -

1. Maximum setpoint is limited to 150 psig / 10.3 bar for constructions with Fluorocarbon (FKM) diaphragm.

# Bulletin 71.1:MR105

## Ordering Guide (continued)

### Main Valve Replacement Parts Kit (Optional)

- Yes, send one replacement parts kit to match this order.

### Actuator Replacement Parts Kit (Optional)

- Yes, send one replacement parts kit to match this order.

### Wireless Position Monitor Mounting Kit (Optional)

- Yes, send one mounting kit for mounting the Topworx™ 4310 or the Fisher® 4320 wireless position monitor.

Regulators Quick Order Guide	
***	Readily Available for Shipment
**	Allow Additional Time for Shipment
*	Special Order, Constructed from Non-Stocked Parts. Consult your local Sales Office for Availability.
Availability of the product being ordered is determined by the component with the longest shipping time for the requested construction.	

Specification Worksheet	
<b>Application:</b>	
Specific Use	_____
Line Size	_____
Fluid Type	_____
Specific Gravity	_____
Temperature	_____
Does the Application Require Overpressure Protection?	
<input type="checkbox"/> Yes <input type="checkbox"/> No	
<b>Pressure:</b>	
Maximum Inlet Pressure	_____
Minimum Inlet Pressure	_____
Differential Pressure	_____
Set Pressure	_____
Maximum Flow	_____
<b>Accuracy Requirements:</b>	
Less Than or Equal To:	
<input type="checkbox"/> 5% <input type="checkbox"/> 10% <input type="checkbox"/> 20% <input type="checkbox"/> 40%	
<b>Construction Material Requirements (if known):</b>	
_____	
_____	

### Industrial Regulators

#### Emerson Process Management Regulator Technologies, Inc.

USA - Headquarters  
McKinney, Texas 75070 USA  
Tel: +1 800 558 5853  
Outside U.S. +1 972 548 3574

Asia-Pacific  
Shanghai 201206, China  
Tel: +86 21 2892 9000

Europe  
Bologna 40013, Italy  
Tel: +39 051 419 0611

Middle East and Africa  
Dubai, United Arab Emirates  
Tel: +971 4811 8100

### Natural Gas Technologies

#### Emerson Process Management Regulator Technologies, Inc.

USA - Headquarters  
McKinney, Texas 75070 USA  
Tel: +1 800 558 5853  
Outside U.S. +1 972 548 3574

Asia-Pacific  
Singapore 128461, Singapore  
Tel: +65 6770 8337

Europe  
Bologna 40013, Italy  
Tel: +39 051 419 0611  
Chartres 28008, France  
Tel: +33 2 37 33 47 00

Middle East and Africa  
Dubai, United Arab Emirates  
Tel: +971 4811 8100

### TESCOM

#### Emerson Process Management Tescom Corporation

USA - Headquarters  
Elk River, Minnesota 55330-2445, USA  
Tels: +1 763 241 3238  
+1 800 447 1250

Europe  
Selmsdorf 23923, Germany  
Tel: +49 38823 31 287

Asia-Pacific  
Shanghai 201206, China  
Tel: +86 21 2892 9499

For further information visit [www.fisherregulators.com](http://www.fisherregulators.com)

The Emerson logo is a trademark and service mark of Emerson Electric Co. All other marks are the property of their prospective owners. Fisher is a mark owned by Fisher Controls International LLC, a business of Emerson Process Management.

The contents of this publication are presented for informational purposes only, and while every effort has been made to ensure their accuracy, they are not to be construed as warranties or guarantees, express or implied, regarding the products or services described herein or their use or applicability. We reserve the right to modify or improve the designs or specifications of such products at any time without notice.

Emerson Process Management Regulator Technologies, Inc. does not assume responsibility for the selection, use or maintenance of any product. Responsibility for proper selection, use and maintenance of any Emerson Process Management Regulator Technologies, Inc. product remains solely with the purchaser.