

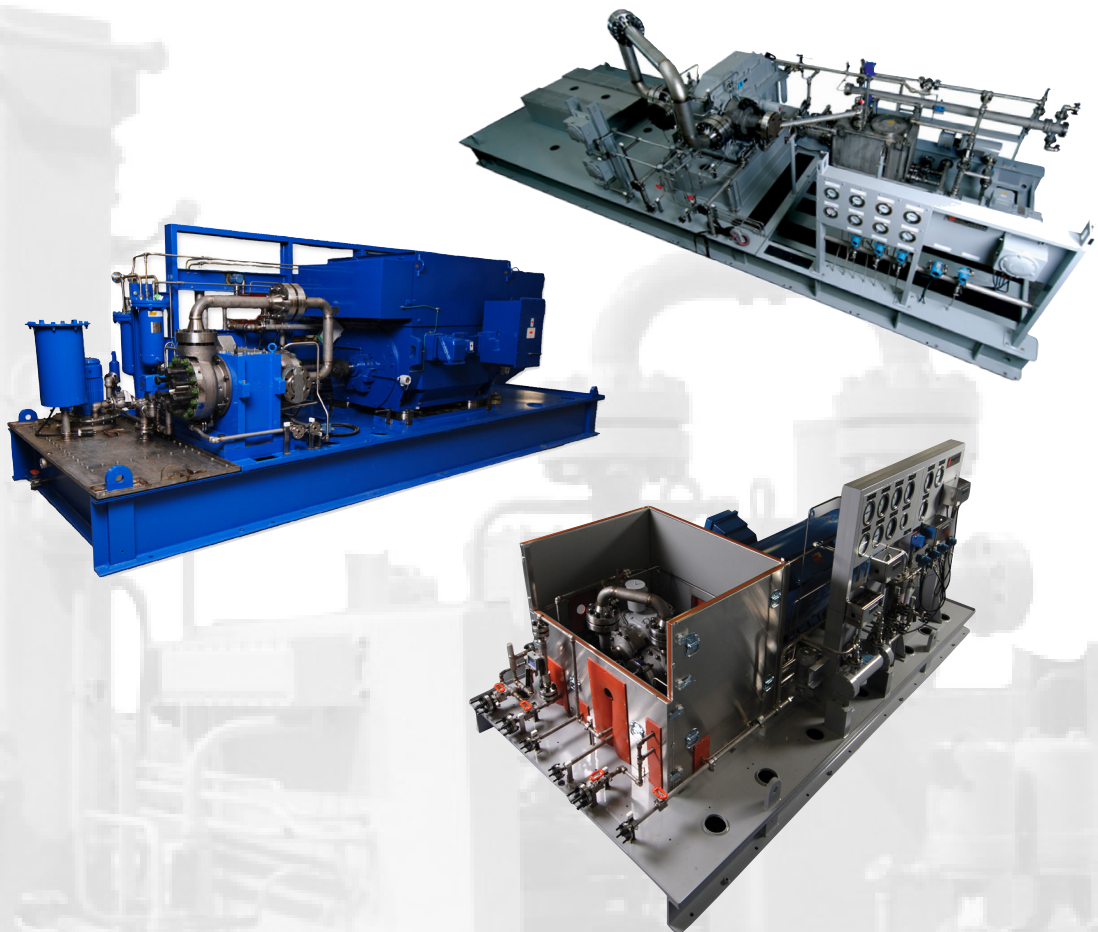

Sundyne
HMP-3000, HMP-5000 and HMP-7000
Integrally Geared Centrifugal Pumps

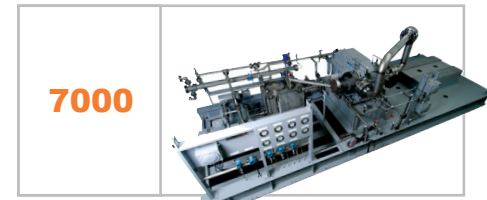

HMP Series

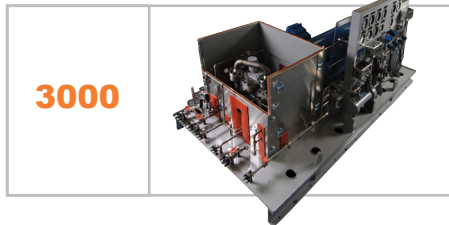

Sundyne HMP

For more than 50 years, Sundyne has led the industry as a fluid handling technology innovator. The HMP series of integrally geared centrifugal pumps continues this tradition of engineering excellence, delivering exceptional power and the rugged reliability people expect from Sundyne in a compact footprint.

Available in scalable configurations – up to three stages on a single gearbox – the HMP series features superior low specific speed hydraulics to deliver maximum efficiency, with each pump engineered to meet the application's unique Best Efficiency Point (BEP). Additionally, HMP pumps will run continuously for 5 years, as specified by exacting API-610 standards. With this combination of flexible features and reduced lifecycle costs, Sundyne HMP pumps are the clear choice for handling heavy duty applications in fertilizer, urea and PTA production.

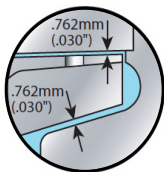

Generous Impeller Clearances

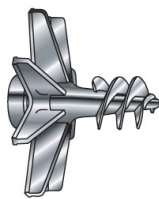

Integral Impeller Inducer

Product Description

First developed by Sundyne in 1967, the HMP series has a proven track record of reliability, with over 300 units installed worldwide handling some of the most challenging applications known to industry.

The robust HMP-Series Sundyne Pumps are end-suction, horizontal, high-speed, two-stage centrifugal pumps designed for use in low flow, high pressure applications. The two stages of an HMP pump can operate either in series or parallel, in order to achieve a broad range of flows and pressures.

The HMP is driven by an integral single helical or spur gear mesh speed-increasing gearbox, providing compactness, design simplicity and optimized reliability over conventional multistage and reciprocating pumps.

The wet ends of the HMP use open face impellers with either a single- or dual-throat diffuser design to optimize performance. Our pioneering development work concerning inducer technology may be used where NPSHa (Net Positive Suction Head Available) is low.

Additionally, mechanical seals in single, tandem or double seal arrangements are available to safely isolate the process. A seal support system is typically included in the HMP package, as well as gearbox lubrication and instrumentation.

Key Features and Benefits

- Centrifugal design — A high performance alternative to positive displacement pumps, providing flexible, pulsation-free flows.
- No wear rings — No impeller clearances to set, making for easy assembly.
- Compact design — With low component weight and small foot print, HMP pumps require minimal space to install.
- Modular design — Allows for increased dependability, easy maintenance, reduced spares inventory and reduced costs.
- Engineered packages — Complete designs custom engineered to meet your specific requirements.
- Open impeller blades & clearance — Mitigates concerns relating to handling particulate substances. Ideal for urea production, resin services and PTA slurry applications.

HMP-3000

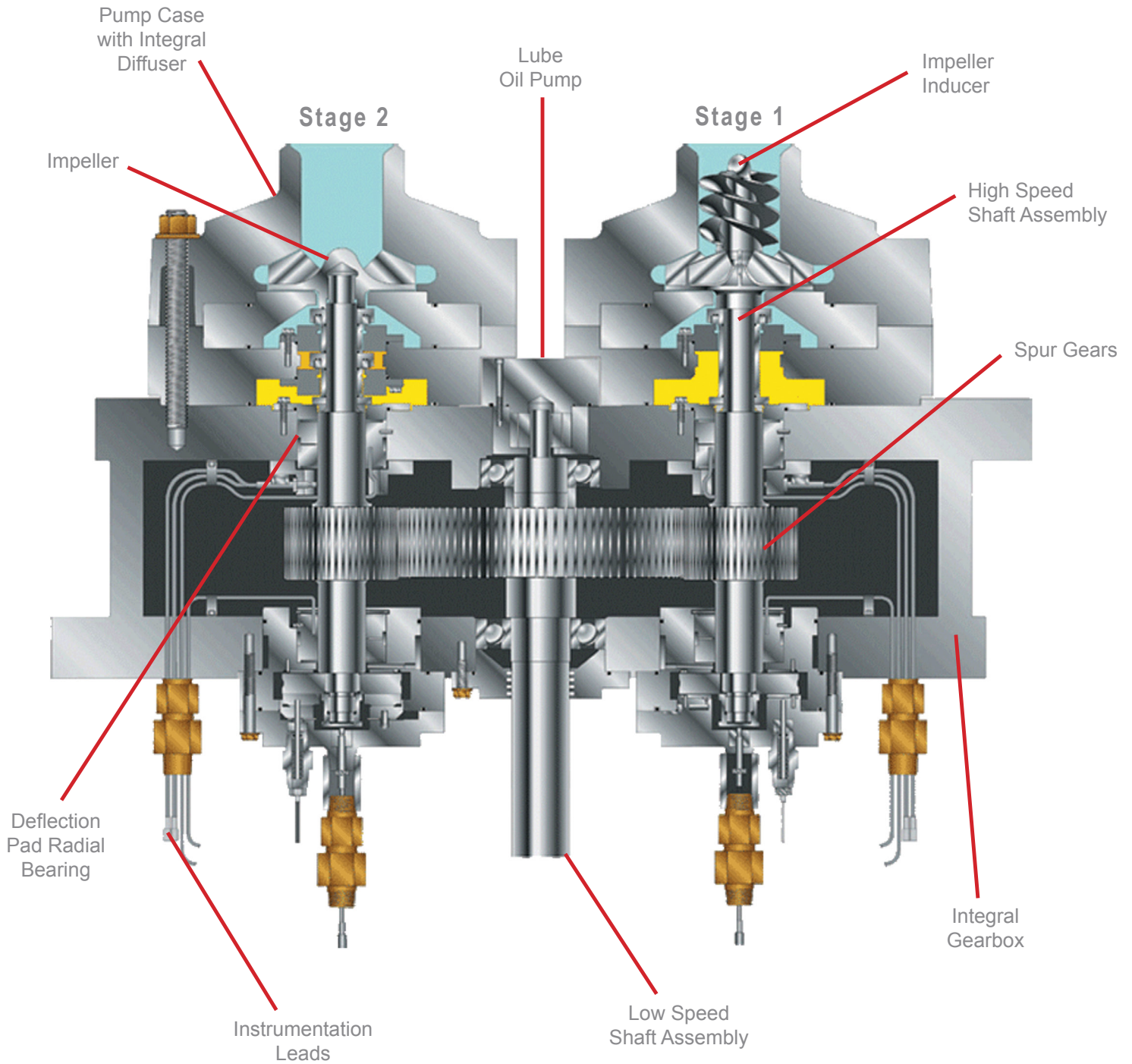

HMP-7000

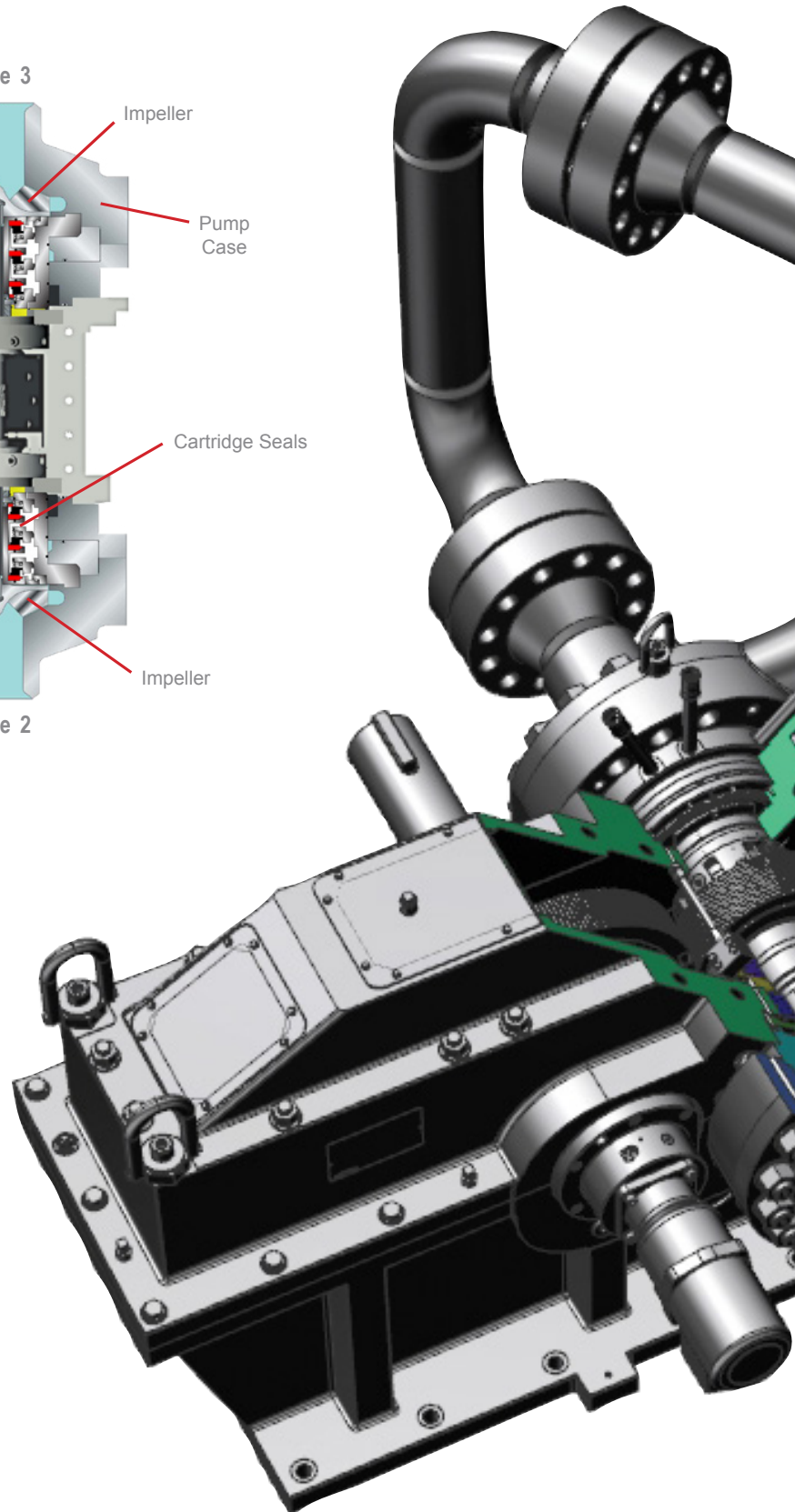
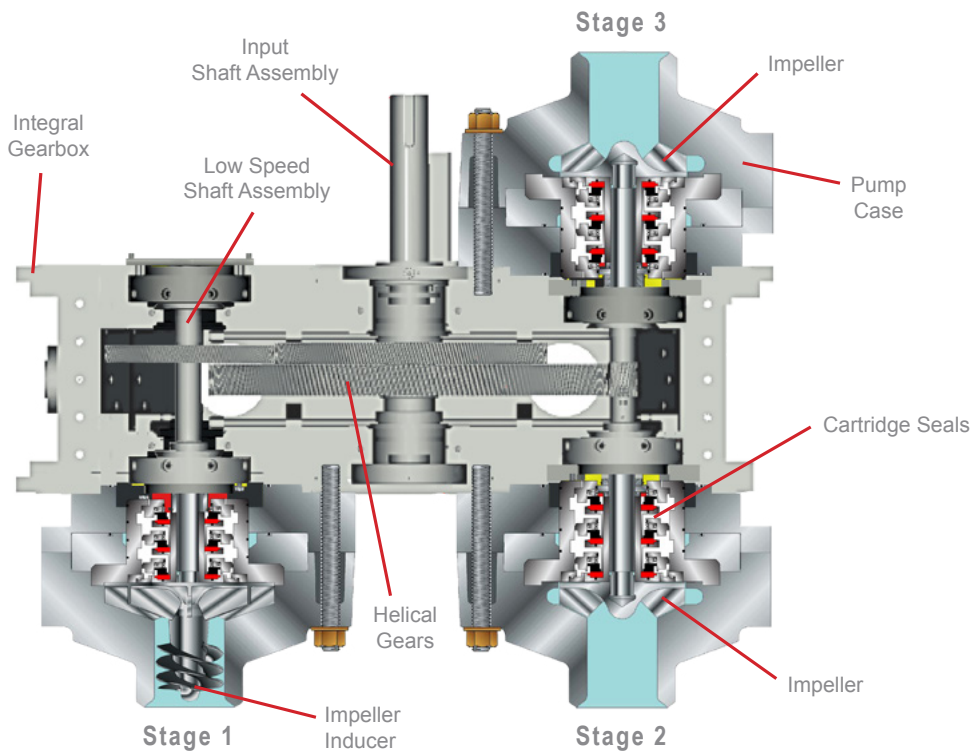

Optional Features

- API seal plans for specific requirements
- Thermocouples or RTDs
- Vibration monitoring
- Parallel arrangement (not shown)
- Proximity probes
- API 614 lube oil console on a common or separate skid

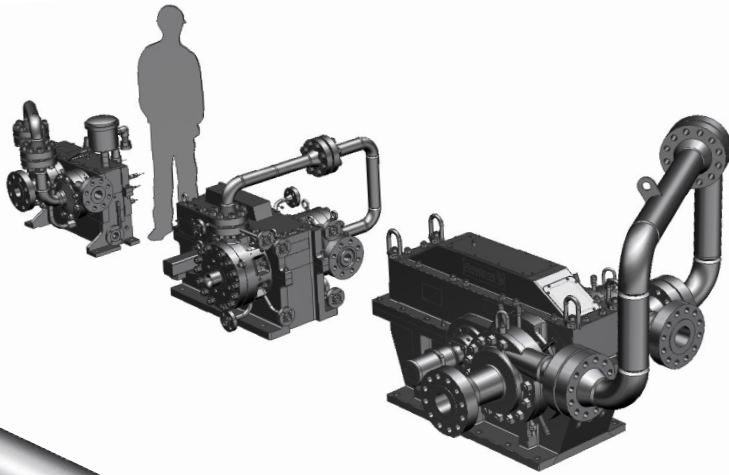

The Sundyne HMP product line consists of three core configurations that are engineered to meet your specific process requirements, allowing for optimal efficiency and rugged reliability even in the most challenging conditions.

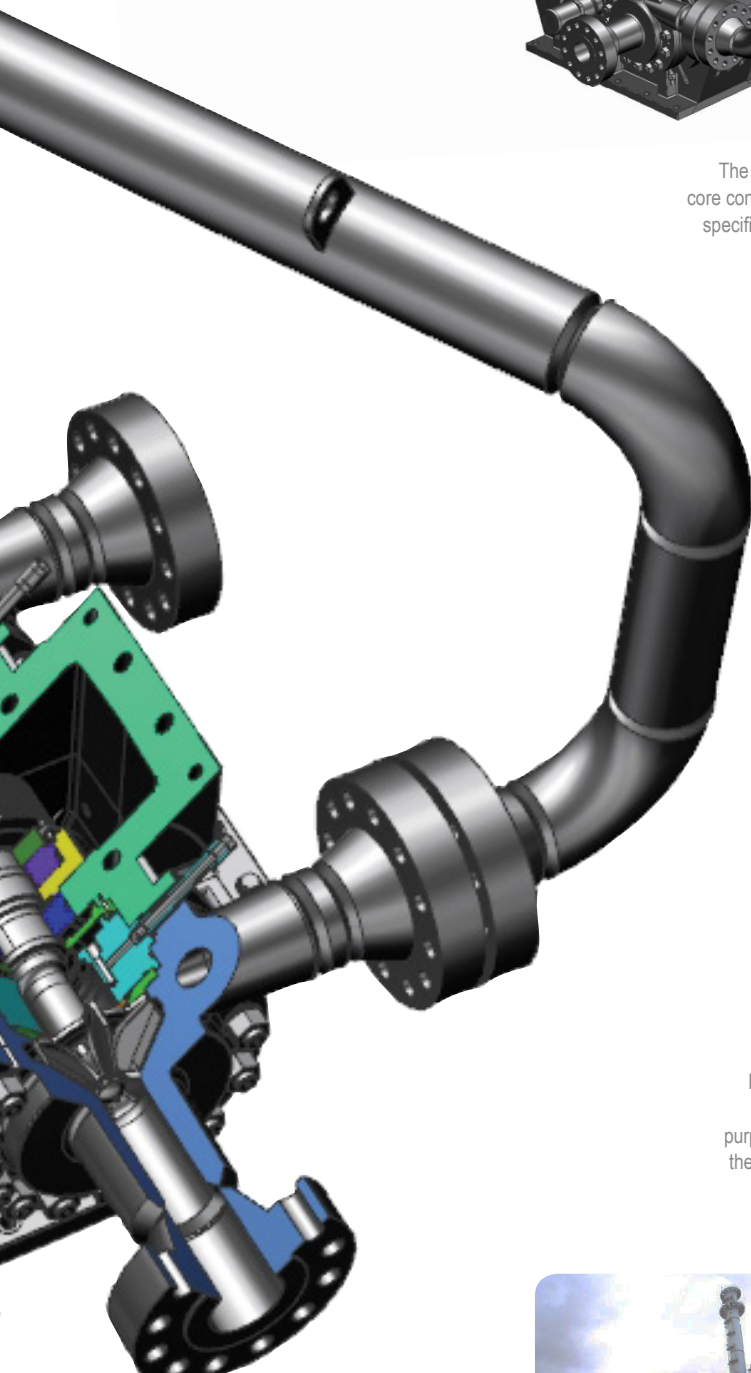

By their nature, petrochemicals are uniquely challenging to handle. The HMP series is purpose-built to execute applications relating to these often caustic substances, offering robust build quality and unflagging performance.



The Sundyne HMP series is designed to withstand harsh operating conditions and aggressive materials that would trash lesser pumps; and when it comes to urea production, these machines are at the top of their class.

Applications

Industrial

- High-Pressure Spray
- Mine Dewatering
- Transfer
- Hydraulic Pressure
- Waste Water Disposal
- Descaling
- High Pressure Cleaning
- Pressure Testing
- Boiler Feed

Oil Production

- Pipeline
- LPG Injection
- Water Injection
- Chemical Injection
- Liquid CO₂ Injection
- Steam Injection
- Transfer Pumps
- Off Shore Installations

Petrochemical

- Resin charge
- LPG Pipeline
- Transfer Service
- PTA Slurry
- Reactor Charge

Urea Production

- Carbamate Recycle
- Ammonia Injection

HMP-5000

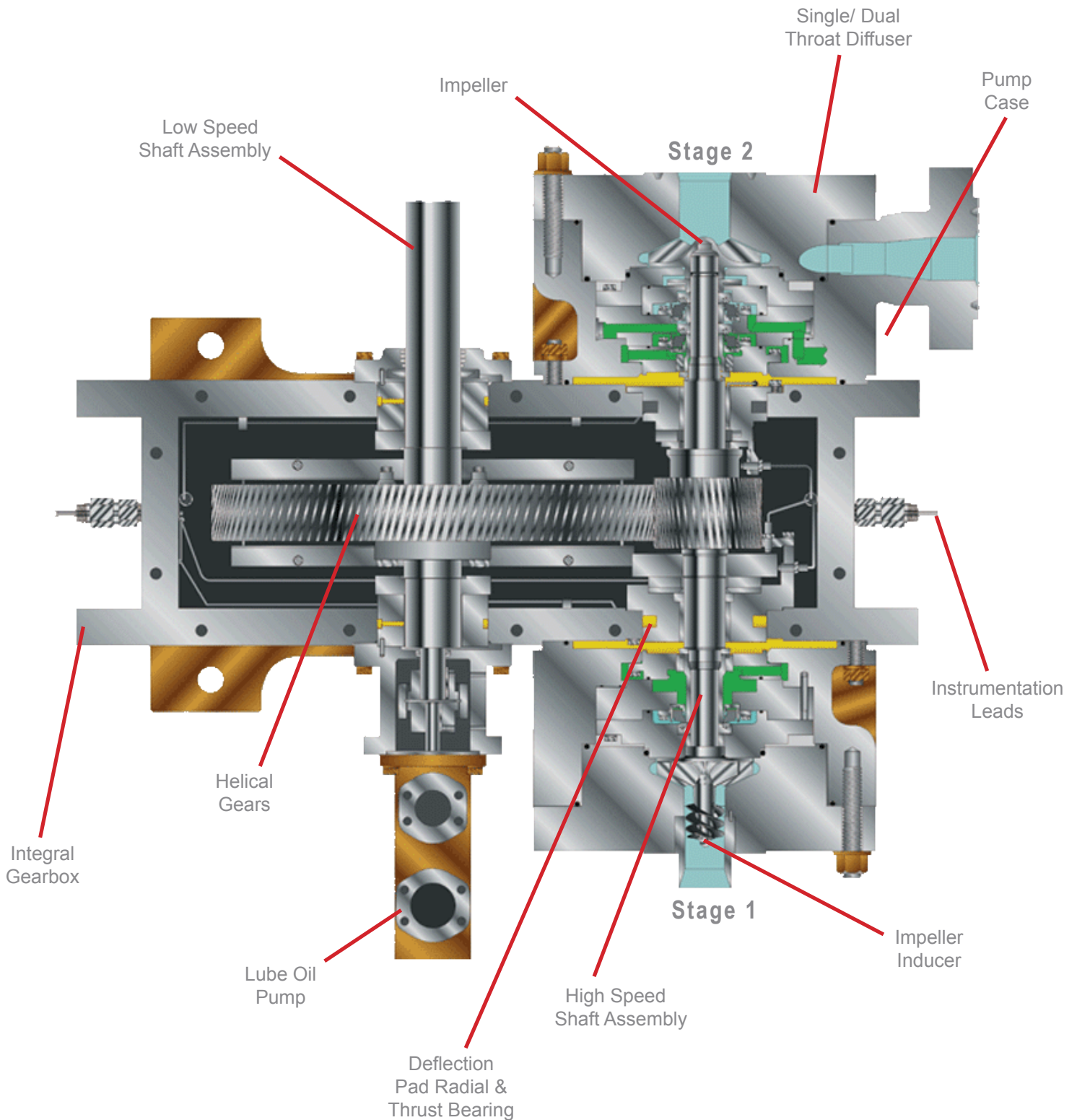

Performance

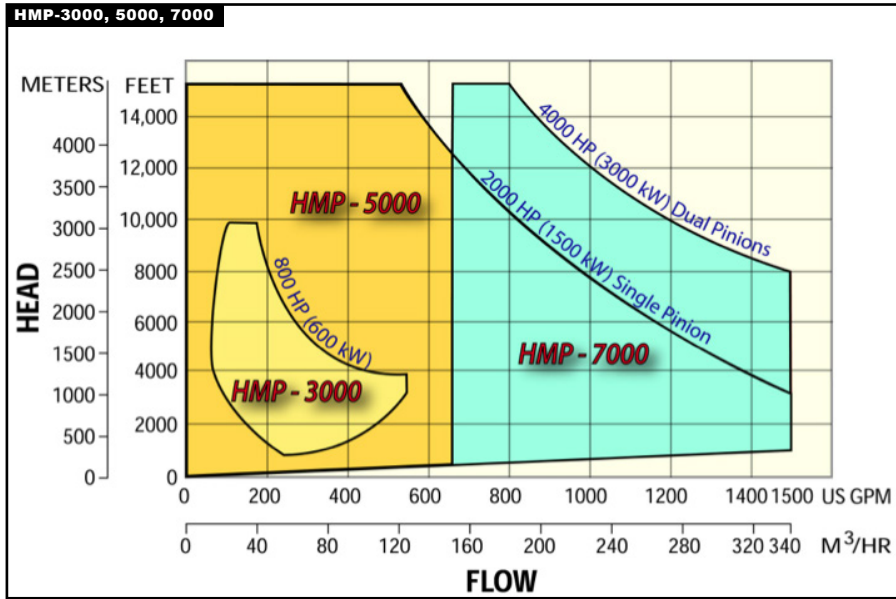

Specifications

	HMP-3000	HMP-5000	HMP-7000
Heads To	10,000 ft (3,050 m)	14,500 ft (4,500 m)	15,000 ft (4,570 m)
Flows To	60 - 440 gpm (8 - 320m ³ /hr)	60 to 1,000 gmp (1 - 182m ³ /hr)	0 to 1,585 gmp (0 - 360m ³ /hr)
Max Power	800 hp (600 kw)	2,500 hp (1,865 kw)	0 - 2,000 hp (0 - 1,500 kw)
Temp Range	-200 to 500°F (-129 to 260°C)	-200 to 500°F (-129 to 260°C)	-40 to 550°F (-40 to 288°C)
Number of Stages	2	2	1, 2, 3 or 4
Max Case Working Pressure	3,750 psi (264 kg/cm ²)	6,000 psi (422 kg/cm ²)	
Max Suction Pressure	425 psi (30 kg/cm ²)	1,000 psi (70 kg/cm ²)	
Standard Delivery	52 weeks	Consult Factory	Consult Factory
Speed Range	8,000 to 22,000 rpm - 60Hz	12,500 to 25,000 rpm - 60Hz	3,000 to 29,000 rpm - 60 Hz
Materials of Construction	316L SS, Duplex SS	316L SS, Duplex SS	Consult Factory
Bearing Materials Available	Steel, Bronze	Steel, Bronze	
Hydrotest Pressure	5,625 psig (395 kg/cm ² g)	9,000 psig (633 kg/cm ² g)	
Max Viscosity	10 cp	10 cp	
Industry Standard	API-610	API-610, ISO 13709	API-610, ISO 13709
Solids Range	0.015" (0.381mm), 400 microns	0.015" (0.381mm), 400 microns	
Motor Details		Custom	NEC - 505, IEC, CENELEC, etc.
Mounting Configurations	Horizontal	Horizontal	Horizontal, Engineered Skid
Dimentional Standards	Custom	Custom	Custom
Number of Available Hydraulics	Custom	Custom	Custom
Seal Configurations Available	Single, Double, Tandem	Single, Double, Tandem	Single, Double, Tandem
Available Inducer	Yes	Yes	Yes
Available Flanges	300#, 600#, 900#, 1,500# ANSI RF or RTJ	300#, 600#, 900#, 1,500#, 2,500# ANSI RF or RTJ	
Pump Case Corrosion Allowance	0.125" (3.175mm)	0.125" (3.175mm)	
Suction and Discharge Size	4x3	4x4	



COMPRESSORS

PUMPS

GENUINE PARTS

SERVICE

Sundyne Headquarters:
Sundyne, LLC
14845 West 64th Avenue
Arvada, Colorado 80007
USA
1-866-Sundyne
Phone: 1.303.425.0800
Fax: 1.303.425.0896
www.sundyne.com

Sundyne China:
Building 1, No. 879 Shen Fu Road
XinZhuang Industrial Zone
Min Hang District
Shanghai, China 201108
Phone: +8621 5055 5005
Fax: +8621 5442 5265

Sundyne France:
Sundyne International S.A.
13-15, Boulevard Eiffel - B.P. 30
21604 Longvic Cedex
France
Phone: +33 380 38 33 00
Fax: +33 380 38 33 66

Sundyne Spain:
Sundyne Marelli Bombas, S.R.L.
Ctra. Madrid-Toledo, Km.30.8
45200 Illescas
Toledo, Spain
Phone: +34 925 53 45 00
Fax: +34 925 51 16 00

Sundyne United Kingdom:
Sundyne HMDKontro Sealless Pumps, Ltd.
Marshall Road
Hampden Park Industrial Estate
Eastbourne East Sussex, BN22 9AN
United Kingdom
Phone: +44 1323 452000
Fax: +44 1323 503369
Email: info@hmdkontro.com

Worldwide Sales Headquarters
Unit 2 Harvington Business Park
Hampden Park Industrial Estate
Brampton Road
Eastbourne East Sussex, BN22 9BN
United Kingdom
Phone: +44(0) 1323 452125

All information provided is
subject to change without notice.
© 2013 Sundyne, LLC
All Rights Reserved. Other logos
and trade names are property of
their respective owners.

HMP Series Brochure
090313: US (v.2) POD

Visit our website at: www.sundyne.com