

# Fisher™ ED and EAD easy-e™ Valves CL125 through CL600

## Contents

Introduction .....	1
Scope of Manual .....	1
Description .....	2
Specifications .....	2
Educational Services .....	3
Installation .....	3
Maintenance .....	4
Packing Lubrication .....	5
Packing Maintenance .....	5
Replacing Packing .....	6
Trim Maintenance .....	10
Disassembly .....	10
Lapping Metal Seats .....	11
Valve Plug Maintenance .....	12
Assembly .....	13
Retrofit: Installing C-seal Trim .....	13
Replacement of Installed C-seal Trim .....	15
Trim Removal (C-seal Constructions) .....	15
Lapping Metal Seats (C-seal Constructions) ..	19
Remachining Metal Seats (C-seal Constructions) .....	19
Trim Replacement (C-seal Constructions) ...	19
ENVIRO-SEAL™ Bellows Seal Bonnet .....	20
Replacing a Plain or Extension Bonnet with an ENVIRO-SEAL Bellows Seal Bonnet (Stem/Bellows Assembly) .....	20
Replacement of an Installed ENVIRO-SEAL Bellows Seal Bonnet (Stem/Bellows Assembly) .....	23

Figure 1. Fisher ED Valve with 667 Actuator



W1916-2

Purging the ENVIRO-SEAL Bellows Seal Bonnet .....	24
Parts Ordering .....	24
Parts Kits .....	25
Parts List .....	29

## Introduction

### Scope of Manual

This instruction manual includes installation, maintenance, and parts information for NPS 1 through 8 Fisher ED valves, and NPS 1 through 6 EAD valves, through CL600 ratings. Refer to separate manuals for instructions covering the actuator and accessories.

Do not install, operate, or maintain ED or EAD valves without being fully trained and qualified in valve, actuator, and accessory installation, operation, and maintenance. To avoid personal injury or property damage, it is important to carefully read, understand, and follow all the contents of this manual, including all safety cautions and warnings. If you have any questions about these instructions, contact your [Emerson sales office](#) or Local Business Partner before proceeding.

Table 1. Specifications

<p><b>End Connection Styles</b></p> <p><b>Cast Iron Valves</b>  <i>Flanged:</i> CL125 flat-face or 250 raised-face flanges per ASME B16.1</p> <p><b>Steel and Stainless Steel Valves</b>  <i>Flanged:</i> CL150, 300, and 600 raised-face or ring-type joint flanges per ASME B16.5  <i>Screwed or Socket Welding:</i> All available ASME B16.11 schedules that are consistent with CL600 per ASME B16.34  <i>Buttwelding:</i> NPS 1 through 8  Schedules 40 or 80 consistent with ASME B16.25</p> <p><b>Maximum Inlet Pressure<sup>(1)</sup></b></p> <p><b>Cast Iron Valves</b>  <i>Flanged:</i> Consistent with CL125B or 250B pressure-temperature ratings per ASME B16.1</p> <p><b>Steel and Stainless Steel Valves</b>  <i>Flanged:</i> Consistent with CL150, 300, and 600<sup>(2)</sup> pressure-temperature ratings per ASME B16.34  <i>Screwed or Welding:</i> Consistent with CL600 pressure-temperature ratings per ASME B16.34</p> <p><b>Shutoff Classifications per ANSI/FCI 70-2 and IEC 60534-4</b></p> <p>Standard: Class II</p>	<p><b>Optional:</b> Class III--For valves with graphite piston ring and 3.4375 inch or larger port diameter; Class IV--For valves with multiple graphite piston rings and 4.375 inch or larger port diameter</p> <p><b>C-seal trim:</b> High-temperature, Class V.  See table 2</p> <p><b>Flow Characteristics</b></p> <p><b>Standard Cages:</b> ■ Linear, ■ quick opening, or ■ equal percentage  <b>Whisper Trim™ and WhisperFlo™ Cages:</b> Linear</p> <p><b>Flow Directions</b></p> <p><b>Linear, Quick Opening, or Equal Percentage Cage:</b>  Normally down  <b>Whisper Trim and WhisperFlo Cages:</b> Always up</p> <p><b>Approximate Weights</b></p> <p>NPS 1 &amp; 1-1/4 valves: 14 kg (30 lb)  NPS 1-1/2 valves: 20 kg (45 lb)  NPS 2 valves: 30 kg (67 lb)  NPS 2-1/2 valves: 45 kg (100 lb)  NPS 3 valves: 57 kg (125 lb)  NPS 4 valves: 77 kg (170 lb)  NPS 6 valves: 159 kg (350 lb)  NPS 8 valves: 408 kg (900 lb)</p>
--	---

1. The pressure/temperature limits in this manual and any applicable standard or code limitation for valve should not be exceeded.

2. Certain bonnet bolting material selections may require a CL600 easy-e valve assembly to be derated. Contact your [Emerson sales office](#) or Local Business Partner.

## Description

These single-port valves have cage guiding, quick-change trim, and balanced push-down-to-close valve plug action. Valve configurations are as follows:

ED--Globe-style valve (figure 1) with metal-to-metal seating for all general applications over a wide variety of pressure drops and temperatures.

EAD--Angle version of ED, used to facilitate piping or in applications where a self-draining valve is required.

C-seal trim is available for ED valves, CL150, 300, and 600, in NPS 2-1/2, 3, 4, 6, and 8. C-seal trim is available for EAD valves, CL150, 300, and 600, in NPS 3, 4, and 6.

With C-seal trim, a balanced valve can achieve high-temperature, Class V shutoff. Because the C-seal plug seal is formed from metal (N07718 nickel alloy) rather than an elastomer, a valve equipped with the C-seal trim can be applied in processes with a fluid temperature of up to 593°C (1100°F), provided other material limits are not exceeded.

## Specifications

Typical specifications for these valves are shown in table 1.

## Educational Services

For information on available courses for Fisher ED and EAD valves, as well as a variety of other products, contact:

Emerson Automation Solutions  
Educational Services - Registration  
Phone: 1-641-754-3771 or 1-800-338-8158  
E-mail: [education@emerson.com](mailto:education@emerson.com)  
[emerson.com/fishervalvetraining](http://emerson.com/fishervalvetraining)

## Installation

### **⚠ WARNING**

Always wear protective gloves, clothing, and eyewear when performing any installation operations to avoid personal injury.

Personal injury or equipment damage caused by sudden release of pressure may result if the valve assembly is installed where service conditions could exceed the limits given in table 1 or on the appropriate nameplates. To avoid such injury or damage, provide a relief valve for over-pressure protection as required by government or accepted industry codes and good engineering practices.

Check with your process or safety engineer for any additional measures that must be taken to protect against process media.

If installing into an existing application, also refer to the WARNING at the beginning of the Maintenance section in this instruction manual.

### **CAUTION**

When ordered, the valve configuration and construction materials were selected to meet particular pressure, temperature, pressure drop, and controlled fluid conditions. Responsibility for the safety of process media and compatibility of valve materials with process media rests solely with the purchaser and end-user. Since some body/trim material combinations are limited in their pressure drop and temperature ranges, do not apply any other conditions to the valve without first contacting your [Emerson sales office](#) or Local Business Partner.

1. Before installing the valve, inspect the valve and associated equipment for any damage and any foreign material.
2. Make certain the valve body interior is clean, that pipelines are free of foreign material, and that the valve is oriented so that pipeline flow is in the same direction as the arrow on the side of the valve.
3. The control valve assembly may be installed in any orientation unless limited by seismic criteria. However, the normal method is with the actuator vertical above the valve. Other positions may result in uneven valve plug and cage wear, and improper operation. With some valves, the actuator may also need to be supported when it is not vertical. For more information, consult your Emerson sales office or Local Business Partner.
4. Use accepted piping and welding practices when installing the valve in the line. For flanged valves, use a suitable gasket between the valve and pipeline flanges.

### **CAUTION**

Depending on valve body materials used, post weld heat treating may be required. If so, damage to internal elastomeric and plastic parts, as well as internal metal parts is possible. Shrink-fit pieces and threaded connections may also loosen. In

general, if post weld heat treating is to be performed, all trim parts should be removed. Contact your [Emerson sales office](#) or Local Business Partner for additional information.

5. With a leak-off bonnet construction, remove the pipe plugs (keys 14 and 16, figure 18) to hook up the leak-off piping. If continuous operation is required during inspection or maintenance, install a three-valve bypass around the control valve assembly.
6. If the actuator and valve are shipped separately, refer to the actuator mounting procedure in the appropriate actuator instruction manual.

Table 2. Additional Shutoff Classification

Valve	Valve Size, NPS	Port Diameter, Inches	Cage Style	Leakage Class	
ED (CL150-600)	2-1/2	2.875	Equal Percentage, Linear, Whisper I, Cavitrol™ III, 1 stage	V (for port diameters from 2.875 through 8-inch with optional C-seal trim)	
	3	3.4375			
	3	2.875	Cavitrol III, 2 stage		
	4	2.875			
	4	4.375	Equal Percentage, Linear, Whisper I, Cavitrol III, 1 stage		
	6	6	5.375		Whisper III (A3, B3, D3, D3), Cavitrol III, 2 stage
			7		Equal Percentage, Linear, Whisper I, Cavitrol III, 1 stage
	8	8	7		Cavitrol III, 2 stage
			8		Equal Percentage, Linear, Whisper I, Cavitrol III, 1 stage

**⚠ WARNING**

Personal injury could result from packing leakage. Valve packing was tightened before shipment; however, the packing might require some readjustment to meet specific service conditions. Check with your process or safety engineer for any additional measures that must be taken to protect against process media.

Valves with ENVIRO-SEAL live-loaded packing or HIGH-SEAL live-loaded packing will not require this initial re-adjustment. See the Fisher instruction manuals, ENVIRO-SEAL Packing System for Sliding-Stem Valves or HIGH-SEAL Live-Loaded Packing System (as appropriate), for packing instructions. If you wish to convert your present packing arrangement to ENVIRO-SEAL packing, refer to the retrofit kits listed in the Parts Kit sub-section near the end of this manual.

## Maintenance

Valve parts are subject to normal wear and must be inspected and replaced as necessary. Inspection and maintenance frequency depends on the severity of service conditions. This section includes instructions for packing lubrication, packing maintenance, trim maintenance, and ENVIRO-SEAL bellows seal bonnet replacement. All maintenance operations may be performed with the valve in the line.

**⚠ WARNING**

Avoid personal injury or property damage from sudden release of process pressure or bursting of parts. Before performing any maintenance operations:

- Do not remove the actuator from the valve while the valve is still pressurized.
- Always wear protective gloves, clothing, and eyewear when performing any maintenance operations to avoid personal injury.
- Disconnect any operating lines providing air pressure, electric power, or a control signal to the actuator. Be sure the actuator cannot suddenly open or close the valve.

- Use bypass valves or completely shut off the process to isolate the valve from process pressure. Relieve process pressure from both sides of the valve. Drain the process media from both sides of the valve.
  - Vent the pneumatic actuator loading pressure and relieve any actuator spring precompression.
  - Use lock-out procedures to be sure that the above measures stay in effect while you work on the equipment.
  - The valve packing box may contain process fluids that are pressurized, *even when the valve has been removed from the pipeline*. Process fluids may spray out under pressure when removing the packing hardware or packing rings, or when loosening the packing box pipe plug.
  - Check with your process or safety engineer for any additional measures that must be taken to protect against process media.
- 

**Note**

Whenever a gasket seal is disturbed by removing or shifting gasketed parts, install a new gasket during reassembly. This ensures a good gasket seal because the used gasket may not seal properly.

---

## Packing Lubrication

---

**Note**

ENVIRO-SEAL or HIGH-SEAL packing does not require lubrication.

---

**⚠ WARNING**

**To avoid personal injury or property damage resulting from fire or explosion, do not lubricate packing used in oxygen service or in processes with temperatures over 260°C (500°F).**

---

If a lubricator or lubricator/isolating valve (figure 2) is provided for PTFE/composition or other packings that require lubrication, it will be installed in place of the pipe plug (key 14, figure 18). Use a good quality silicon-based lubricant. Do not lubricate packing used in oxygen service or in processes with temperatures over 260°C (500°F). To operate the lubricator, simply turn the cap screw clockwise to force the lubricant into the packing box. The lubricator/isolating valve operates the same way except open the isolating valve before turning the cap screw and then close the isolating valve after lubrication is completed.

## Packing Maintenance

---

**Note**

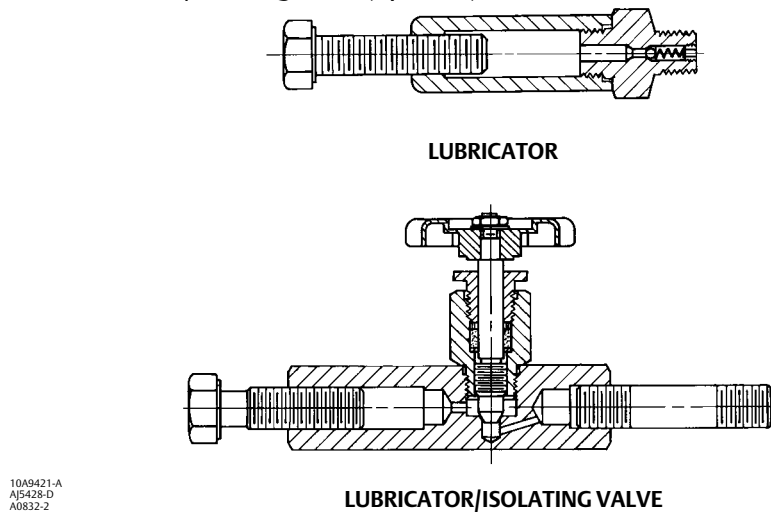
For valves with ENVIRO-SEAL packing, see the Fisher instruction manual, ENVIRO-SEAL Packing System for Sliding-Stem Valves, [D101642X012](#), for packing instructions.

For valves with HIGH-SEAL packing, see the Fisher instruction manual, HIGH-SEAL Live-Loaded Packing System, [D101453X012](#), for packing instructions.

---

Key numbers refer to figure 3 for PTFE V-ring packing and to figure 4 for PTFE/composition packing, unless otherwise indicated.

Figure 2. Lubricator and Lubricator/Isolating Valve (optional)



For spring-loaded single PTFE V-ring packing, the spring (key 8, figure 3) maintains a sealing force on the packing. If leakage is noted around the packing follower (key 13, figure 3), check to be sure the shoulder on the packing follower is touching the bonnet. If the shoulder is not touching the bonnet, tighten the packing flange nuts (key 5, figure 18) until the shoulder is against the bonnet. If leakage cannot be stopped in this manner, proceed to the Replacing Packing procedure.

If there is undesirable packing leakage with other than spring-loaded packing, first try to limit the leakage and establish a stem seal by tightening the packing flange nuts.

If the packing is relatively new and tight on the stem, and if tightening the packing flange nuts does not stop the leakage, the valve stem may be worn or nicked so that a seal cannot be made. The surface finish of a new valve stem is critical for making a good packing seal. If the leakage comes from the outside diameter of the packing, the leakage may be caused by nicks or scratches around the packing box wall. If performing any of the following procedures, inspect the valve stem and packing box wall for nicks and scratches.

## Replacing Packing

### **▲ WARNING**

Refer to the **WARNING** at the beginning of the Maintenance section in this instruction manual.

1. Isolate the control valve from the line pressure, release pressure from both sides of the valve body, and drain the process media from both sides of the valve. If using a power actuator, also shut off all pressure lines to the power actuator, and release all pressure from the actuator. Use lock-out procedures to be sure that the above measures stay in effect while you work on the equipment.
2. Disconnect the operating lines from the actuator and any leak-off piping from the bonnet. Disconnect the stem connector, then remove the actuator from the valve by unscrewing the yoke locknut (key 15, figure 18) or the hex nuts (key 26, figure 18).

Figure 3. PTFE V-Ring Packing Arrangements for Plain or Extension Bonnets

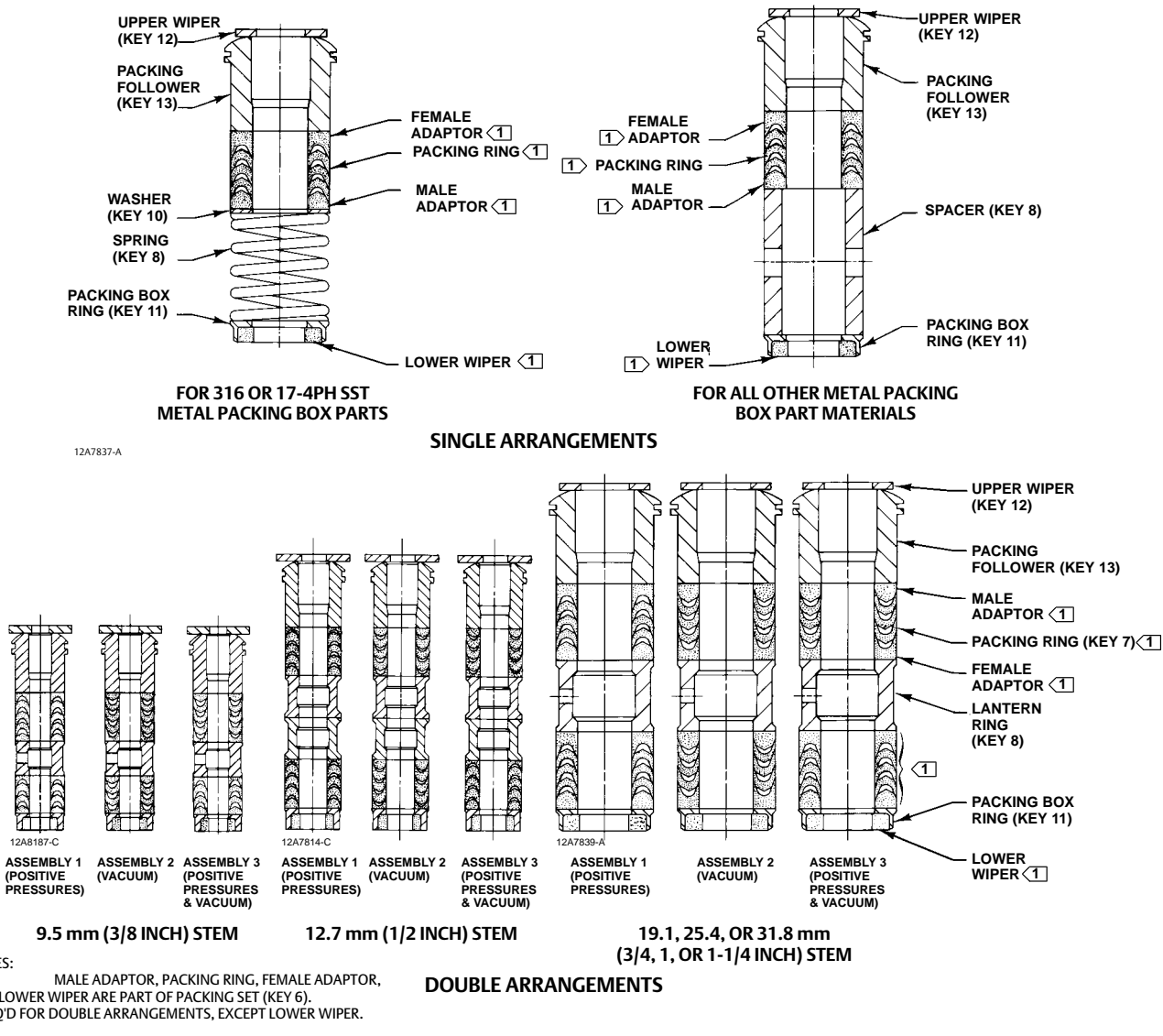


Table 3. Body-to-Bonnet Bolt Torque Guidelines

Valve Size, NPS		Bolt Torques <sup>(1, 3)</sup>			
ED	EAD	SA193-B7		SA193-B8M <sup>(2)</sup>	
		N•m	Lbf•ft	N•m	Lbf•ft
1-1/4 or less	1	129	95	64	47
1-1/2, 1-1/2 x 1, 2, or 2 x 1	2 or 2 x 1	96	71	45	33
2-1/2 or 2-1/2 x 1-1/2	3 or 3 x 1-1/2	129	95	64	47
3, 3 x 2, or 3 x 2-1/2	4 or 4 x 2	169	125	88	65
4, 4 x 2-1/2, or 4 x 3	6 or 6 x 2-1/2	271	200	156	115
6	---	549	405	366	270
8	---	746	550	529	390

1. Determined from laboratory tests.  
 2. SA193-B8M annealed.  
 3. For other materials, contact your [Emerson sales office](#) or Local Business Partner for torque values.

3. Loosen the packing flange nuts (key 5, figure 18) so that the packing is not tight on the valve stem. Remove any travel indicator parts and stem locknuts from the valve stem threads.

## **⚠ WARNING**

**To avoid personal injury or property damage caused by uncontrolled movement of the bonnet, loosen the bonnet by following the instructions in the next step. Do not remove a stuck bonnet by pulling on it with equipment that can stretch or store energy in any other manner. The sudden release of stored energy can cause uncontrolled movement of the bonnet.**

### **Note**

The following step also provides additional assurance that the valve body fluid pressure has been relieved.

## **CAUTION**

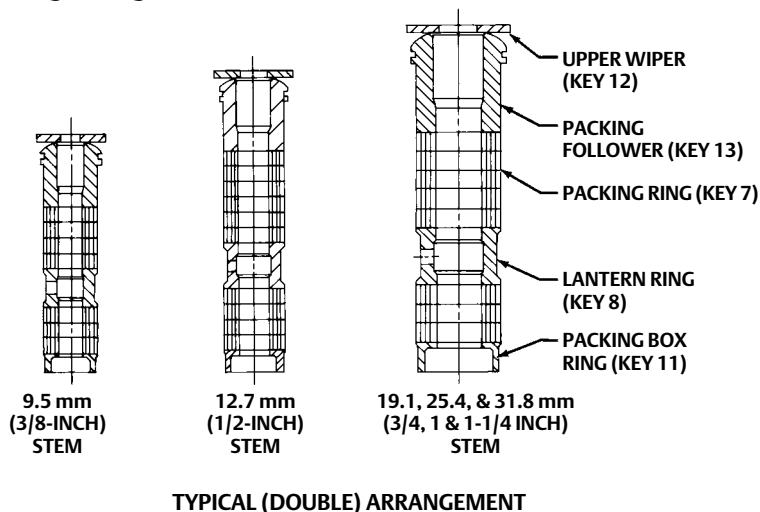
**Avoid damaging the seating surface caused by the valve plug and stem assembly dropping from the bonnet (key 1, figure 18) after being lifted part way out. When lifting the bonnet, temporarily install a valve stem locknut on the valve stem. This locknut will prevent the valve plug and stem assembly from dropping out of the bonnet.**

**If the cage starts to lift with the bonnet, tap it with a plastic mallet, or other soft material, to be sure it stays in the valve.**

4. Hex nuts (key 16, figure 19, 20, or 21) or cap screws (not shown) attach the bonnet (key 1, figure 18) to the valve body (key 1, figure 19, 20, or 21). Loosen these nuts or cap screws approximately 3 mm (1/8 inch). Then loosen the body-to-bonnet gasketed joint by either rocking the bonnet or prying between the bonnet and valve. Work the prying tool around the bonnet until the bonnet loosens. If no fluid leaks from the joint, remove the nuts or cap screws completely and carefully lift the bonnet off the valve.
5. Remove the locknut and separate the valve plug and stem from the bonnet. Set the parts on a protective surface to prevent damage to gasket or seating surfaces.
6. Remove the bonnet gasket (key 10, figure 19, 20, or 21) and cover the opening in the valve to protect the gasket surface and prevent foreign material from getting into the valve body cavity.
7. Remove the packing flange nuts, packing flange, upper wiper, and packing follower (keys 5, 3, 12, and 13, figure 18). Carefully push out all the remaining packing parts from the valve side of the bonnet using a rounded rod or other tool that will not scratch the packing box wall. Clean the packing box and the metal packing parts.
8. Inspect the valve stem threads and packing box surfaces for any sharp edges which might cut the packing. Scratches or burrs could cause packing box leakage or damage to the new packing. If the surface condition cannot be improved by light sanding, replace the damaged parts by following the appropriate steps in the Trim Maintenance procedure.
9. Remove the cover protecting the valve body cavity and install a new bonnet gasket (key 10, figure 19 through 21), making sure the gasket seating surfaces are clean and smooth. Place the valve plug and stem into the valve body, making sure it is properly centered on the seat ring. Then slide the bonnet over the stem and onto the stud bolts (key 16, figure 19, 20, or 21) or onto the valve body cavity if cap screws (not shown) will be used instead.



Figure 4. PTFE/Composition Packing Arrangements for Plain or Extension Bonnets



12A8088-A  
12A7815-A  
12A8173-A  
A5904

**Note**

Proper performance of the bolting procedures in step 10 compresses the spiral wound gasket (key 12, figure 19 or 20) or load ring (key 26, figure 21) enough to both load and seal the seat ring gasket (key 13, figure 19, 20, or 21). It also compresses the outer edge of the bonnet gasket (key 10, figure 19 through 21) enough to seal the body-to-bonnet joint.

The bolting procedures in step 10 include--but are not limited to--ensuring that bolting threads are clean, and evenly tightening the cap screws, or the nuts onto the studs, in a crisscross pattern. Tightening one cap screw or nut may loosen an adjacent cap screw or nut. Repeat the crisscross tightening pattern several times until each cap screw or nut is tight and the body-to-bonnet seal is made. When the operating temperature has been reached, perform the torquing procedure once again.

10. Install bolting, using accepted bolting procedures during tightening, so that the body-to-bonnet joint will withstand test pressures and application service conditions. Use the bolt torques in table 3 as guidelines.
11. Install new packing and the metal packing box parts according to the appropriate arrangement in figure 3, 4, or 5. Place a smooth-edged pipe over the valve stem and gently tap each soft packing part into the packing box.
12. Slide the packing follower, upper wiper, and packing flange (keys 13, 12, and 3, figure 18) into position. Lubricate the packing flange studs (key 4, figure 18) and the faces of the packing flange nuts (key 5, figure 18). Install the packing flange nuts.
13. For spring-loaded PTFE V-ring packing, tighten the packing flange nuts until the shoulder on the packing follower (key 13, figure 18) contacts the bonnet.

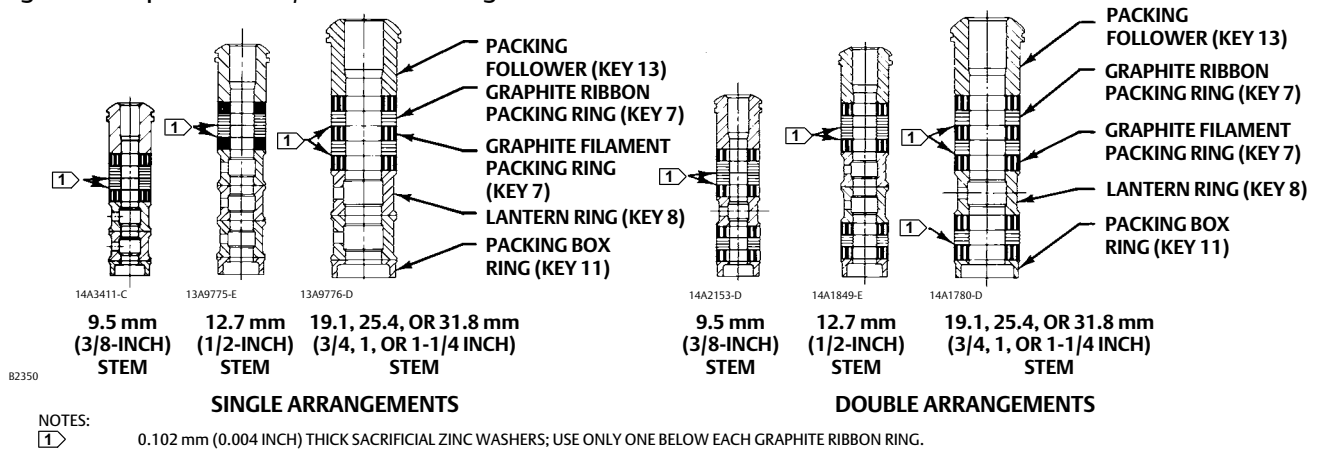
For **graphite packing**, tighten the packing flange nuts to the maximum recommended torque shown in table 4. Then, loosen the packing flange nuts, and retighten them to the recommended minimum torque shown in table 4.

For **other packing types**, tighten the packing flange nuts alternately in small equal increments until one of the nuts reaches the minimum recommended torque shown in table 4. Then, tighten the remaining flange nut until the packing flange is level and at a 90-degree angle to the valve stem.

For **ENVIRO-SEAL or HIGH-SEAL live-loaded packing**, refer to the note at the beginning of Packing Maintenance.

14. Mount the actuator on the valve assembly and reconnect the actuator and valve stem according to the procedure in the appropriate actuator instruction manual.

Figure 5. Graphite Ribbon/Filament Packing for Plain or Extension Bonnets



## Trim Maintenance

### ⚠ WARNING

Observe the warning at the start of the Maintenance section.

For C-seal construction, see the appropriate C-seal sections in this instruction manual.

Except where indicated, key numbers in this section are referenced in figure 19 for standard NPS 1 through 6 constructions, figure 20 for Whisper Trim III cage detail, figure 21 for the NPS 8 ED valve, and figures 22 and 23 for WhisperFlo trim. Some valve plug constructions require three piston rings (key 6).

### Disassembly

1. Remove the actuator and the bonnet according to steps 1 through 5 of the Replacing Packing procedure in the Maintenance section.

### ⚠ WARNING

Avoid personal injury or property damage from valve or packing leakage.

The graphite piston rings in an ED or EAD valve are brittle and in two pieces. Use care to avoid damage to the piston rings caused by dropping or rough handling.

Any damage to the gasket sealing surfaces could cause the valve to leak. The surface finish of the valve stem (key 7) is critical for making a good packing seal. The inside surface of the cage or cage/baffle assembly (key 3), or cage retainer (key 31), is critical for smooth operation of the valve plug and for making a seal with the piston rings (key 6). The seating surfaces of the valve plug (key 2) and seat ring (key 9) are critical for proper shutoff. Protect these parts accordingly while disassembling the trim.

2. Remove the packing flange nuts, packing flange, upper wiper, and packing follower (keys 5, 3, 12, and 13, figure 18). Carefully push out all the remaining packing parts from the valve side of the bonnet using a rounded rod or other tool that will not scratch the packing box wall. Clean the packing box and the metal packing parts.
3. Inspect the valve stem threads and packing box surfaces for any sharp edges which might cut the packing. Scratches or burrs could cause packing box leakage or damage to the new packing. If the surface condition cannot be improved by light sanding, replace the damaged parts.

Table 4. Recommended Torque for Packing Flange Nuts

VALVE STEM DIAMETER		PRESSURE RATING	GRAPHITE TYPE PACKING				PTFE TYPE PACKING			
			Minimum Torque		Maximum Torque		Minimum Torque		Maximum Torque	
mm	Inches		N•m	Lbf•in	N•m	Lbf•in	N•m	Lbf•in	N•m	Lbf•in
9.5	3/8	CL125, 150	3	27	5	40	1	13	2	19
		CL250, 300	4	36	6	53	2	17	3	26
		CL600	6	49	8	73	3	23	4	35
12.7	1/2	CL125, 150	5	44	8	66	2	21	4	31
		CL250, 300	7	59	10	88	3	28	5	42
		CL600	9	81	14	122	4	39	7	58
19.1	3/4	CL125, 150	11	99	17	149	5	47	8	70
		CL250, 300	15	133	23	199	7	64	11	95
		CL600	21	182	31	274	10	87	15	131
25.4	1	CL300	26	226	38	339	12	108	18	162
		CL600	35	310	53	466	17	149	25	223
31.8	1-1/4	CL300	36	318	54	477	17	152	26	228
		CL600	49	437	74	655	24	209	36	314

- Remove the load ring (key 26) from an NPS 8 ED valve, or the cage adaptor (key 4) from any restricted-trim valve through NPS 4, and wrap it for protection.
- On an NPS 6 ED valve with a Whisper Trim III cage or WhisperFlo trim, remove the bonnet spacer (key 32) and bonnet gasket (key 10) on top of the spacer. Then on any construction with a cage retainer (key 31), remove the cage retainer and its associated gaskets. A Whisper Trim III and WhisperFlo cage retainer has two 3/8 inch-16 UNC tappings in which screws or bolts can be installed for lifting.
- Remove the cage or cage/baffle assembly (key 3) and the associated gaskets (keys 10, 11, and 12), and shim (key 51 for the ED valve, key 27 for the EAD valve). If the cage is stuck in the valve, use a rubber mallet to strike the exposed portion of the cage at several points around its circumference.
- Remove the seat ring or liner (key 9), seat ring gasket (key 13), and the seat ring adaptor (key 5) and adaptor gasket (key 14) where used in a restricted-trim seat ring construction.
- Inspect parts for wear or damage which would prevent proper operation of the valve. Replace or repair trim parts according to the following procedure for Lapping Metal Seats or other valve plug maintenance procedures as appropriate.

### Lapping Metal Seats

#### CAUTION

To avoid damaging the ENVIRO-SEAL bellows seal bonnet assembly, do not attempt to lap the metal seating surfaces. The design of the assembly prevents rotation of the stem and any forced lapping rotation will damage internal components of the ENVIRO-SEAL Bellows Seal bonnet.

With metal-seat constructions, seating surfaces of the valve plug and seat ring or liner (keys 2 and 9, figure 19, 20, or 21) can be lapped for improved shutoff. (Deep nicks should be machined out rather than ground out.) Use a good quality lapping compound of a mixture of 280 to 600-grit. Apply compound to the bottom of the valve plug.

Assemble the valve to the extent that the cage and the cage retainer and bonnet spacer (if used) are in place and the bonnet is bolted to the valve. A simple handle can be made from a piece of strap iron locked to the valve plug stem with nuts. Rotate the handle alternately in each direction to lap the seats. After lapping, remove the bonnet and clean the seat surfaces. Completely assemble as described in the Assembly portion of the Trim Maintenance procedure and test the valve for shutoff. Repeat the lapping procedure if leakage is still excessive.

## Valve Plug Maintenance

Except where indicated, key numbers in this section are referenced in figure 19 for standard NPS 1 through 6 constructions, figure 20 for Whisper Trim III detail, figure 21 for the NPS 8 ED valve, and figures 22 and 23 for WhisperFlo trim. Some valve plug constructions require three piston rings (key 6).

### CAUTION

**To avoid the piston ring (key 6) not sealing properly, be careful not to scratch the surfaces of the ring groove in the valve plug or any of the surfaces of the replacement ring.**

1. With the valve plug (key 2) removed according to the Disassembly portion of the Trim Maintenance procedure, proceed as appropriate:

**For the carbon-filled PTFE piston ring,** The ring is split in one place. If there is visible damage, spread the ring slightly and remove it from the groove in the valve plug.

**To install a carbon-filled PTFE piston ring,** Spread the ring apart slightly at the split and install it over the stem and into the groove in the valve plug. The open side must face along the stem, depending on flow directions, as shown in view A of figure 19.

**For the graphite piston ring,** The ring can be easily removed since it is in two pieces. A new graphite piston ring is furnished as a complete ring. Use a vise with smooth or taped jaws to break this replacement ring into halves. Place the new ring in the vise so that the jaws will compress the ring into an oval. Slowly compress the ring until it snaps on both sides. If one side snaps first, do not try to tear or cut the other side. Instead, keep compressing the ring until the other side snaps. Be sure to match the broken ends when installing the ring in the valve plug groove.

### CAUTION

**Never reuse an old stem or adaptor with a new valve plug. Using an old stem or adaptor with a new plug requires drilling a new pin hole in the stem (or adaptor in case an ENVIRO-SEAL bellows seal bonnet is being used). This drilling weakens the stem or adaptor and may cause failure in service. However, a used valve plug may be reused with a new stem or adaptor.**

#### Note

For plain bonnets and style 1 extension bonnets, the valve plug (key 2), valve stem (key 7), and pin (key 8) are available completely assembled. Refer to the Key 2, 7, and 8 Valve Plug and Stem Assembly tables in the Parts List.

2. To replace the valve stem (key 7), drive out the pin (key 8). Unscrew the valve plug from the stem or adaptor.
3. To replace the adaptor (key 24, figure 18) on ENVIRO-SEAL bellows seal bonnets, place the plug stem assembly and valve plug in a soft-jaw chuck or other type of vise so that the jaws grip a portion of the valve plug that is not a seating surface. Drive out the pin (key 36, figure 18). Reverse the plug stem assembly and valve plug in the soft-jaw chuck or vise. Grip the flat areas on the valve stem just below the threads for the actuator/stem connection. Unscrew the valve plug/adaptor assembly (key 24, figure 18) from the valve stem assembly (key 20, figure 18).
4. Screw the new stem or adaptor into the valve plug. Tighten to the torque value given in table 5. Refer to table 5 to select the proper drill size. Drill through the stem or adaptor, using the hole in the valve plug as a guide. Remove any chips or burrs and drive in a new pin to lock the assembly.
5. For ENVIRO-SEAL bellows seal bonnets, grip the flats of the stem extending out of the top of the bellows shroud with a soft-jaw chuck or other type of vise. Screw the valve plug/adaptor assembly onto the valve stem. Tighten as

necessary to align the pin hole in the stem with one of the holes in the adaptor. Secure the adaptor to the stem with a new pin.

## Assembly

Except where indicated, key numbers are referenced in figure 19 for standard NPS 1 through 6 constructions, figure 20 for Whisper Trim III detail, figure 21 for the NPS 8 ED valve, and figures 22 and 23 for WhisperFlo trim.

Table 5. Valve Stem Connection Torque and Pin Replacement

VALVE STEM CONNECTION (VSC)		TORQUE, MINIMUM TO MAXIMUM		DRILL SIZE, INCH
mm	Inch	N•m	Lbf•ft	
9.5	3/8	40 to 47	25 to 35	3/32
12.7	1/2	81 to 115	60 to 85	1/8
19.1	3/4	237 to 339	175 to 250	3/16
25.4	1	420 to 481	310 to 355	1/4
31.8	1-1/4	827 to 908	610 to 670	1/4

1. With a restricted-trim seat ring construction, install the adaptor gasket (key 14) and seat ring adaptor (key 5).
2. Install the seat ring gasket (key 13), seat ring or liner (key 9).
3. Install the cage or cage/baffle assembly (key 3). Any rotational orientation of the cage or assembly with respect to the valve is acceptable. A Whisper Trim III cage designated by level A3, B3, or C3 may be installed with either end up. The level D3 cage/baffle assembly, however, must be installed with the hole pattern end next to the seat ring. If a cage retainer (key 31) is to be used, place it on top of the cage.
4. Slide the valve plug (key 2) and stem assembly, or valve plug and ENVIRO-SEAL bellows seal assembly, into the cage until the piston ring(s) is level with the top of the cage (key 3) or cage retainer (key 31).
5. Installing piston rings (key 6):
  - a. For valve plugs with a single piston ring: Make sure the piston ring is evenly engaged into the entrance chamfer at the top of the cage or cage retainer ring. Carefully press the piston ring into the cage or cage retainer ring.
  - b. For valve plugs with multiple piston rings: As each piston ring is slid into the cage, make sure the ring is evenly engaged in the entrance chamfer at the top of the cage or cage retainer. Also, make sure to offset the fracture in the rings to minimize leakage. Carefully press each piston ring into the cage or cage retainer ring.
6. Place the gaskets (keys 12, 11 or 14 if used, and 10) and the shim (key 27 or 51) if used, on top of the cage or cage retainer. If there is a cage adaptor (key 4) or a bonnet spacer (key 32), set it on the cage or cage retainer gaskets and place another flat sheet gasket (key 10) on top of the adaptor or spacer. If there is only a cage retainer, place another flat sheet gasket on the retainer.
7. With an NPS 8 ED valve, install the load ring (key 26).
8. Mount the bonnet on the valve and complete assembly according to steps 10 through 14 of the Replacing Packing procedure. Be sure to observe the note prior to step 10.

## Retrofit: Installing C-seal Trim

### Note

Additional actuator thrust is required for a valve with C-seal trim. When installing C-seal trim in an existing valve, contact your [Emerson sales office](#) or Local Business Partner for assistance in determining new actuator thrust requirements.

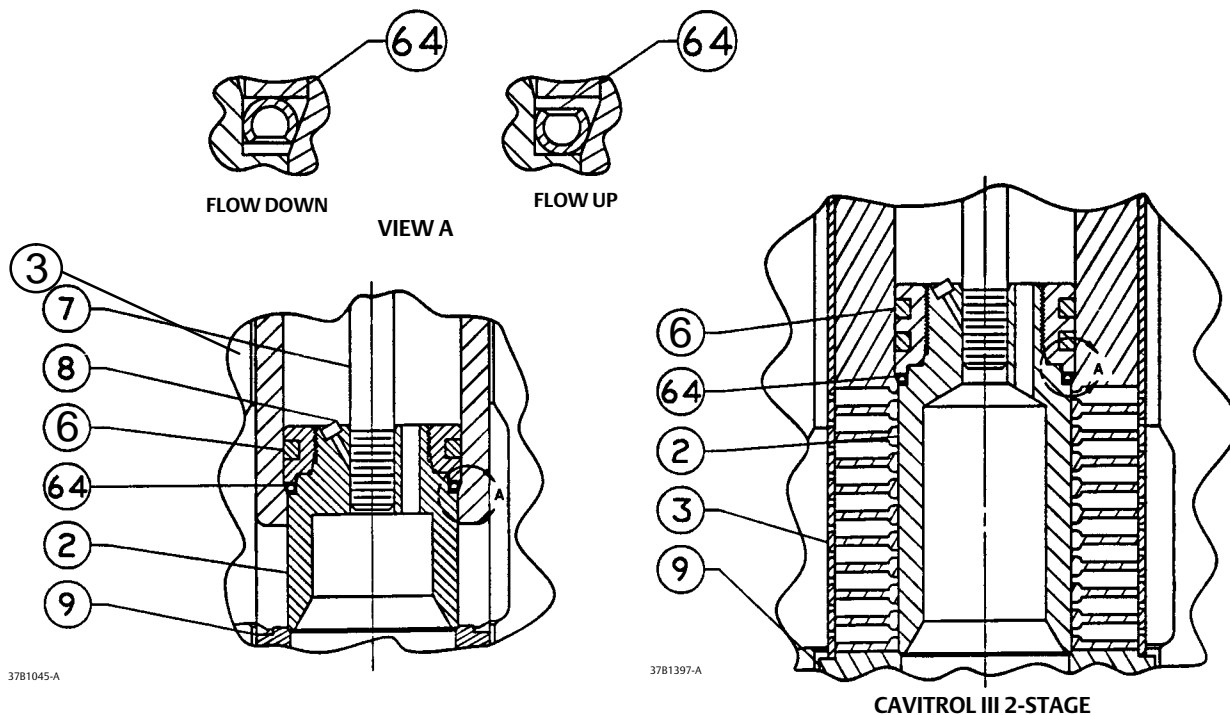
Assemble the new valve plug/retainer assembly (with C-seal plug seal) using the following instructions:

## CAUTION

To avoid leakage when the valve is returned to service, use appropriate methods and materials to protect all sealing surfaces of the new trim parts while assembling the individual parts and during installation in the valve body.

1. Apply a suitable high-temperature lubricant to the inside diameter of the C-seal plug seal. Also, lubricate the outside diameter of the valve plug where the C-seal plug seal must be pressed into the proper sealing position (figure 6).
2. Orient the C-seal plug seal for correct sealing action based on the process fluid flow direction through the valve.
  - The open interior of the C-seal plug seal must face up in a valve with flow-up construction (figure 6).
  - The open interior of the C-seal plug seal must face down in a valve with flow-down construction (figure 6).

Figure 6. Fisher ED with C-seal Trim



### Note

An installation tool must be used to properly position the C-seal plug seal on the valve plug. A tool is available as a Fisher spare part or a tool could be manufactured following the dimensions given in figure 7.

3. Place the C-seal plug seal over the top of the valve plug and press the C-seal plug seal onto the plug using the C-seal installation tool. Carefully press the C-seal plug seal onto the plug until the installation tool contacts the horizontal reference surface of the valve plug (figure 8).
4. Apply a suitable high-temperature lubricant to the threads on the plug. Then, place the C-seal retainer onto the plug and tighten the retainer using an appropriate tool such as a strap wrench.

5. Using an appropriate tool such as a center punch, stake the threads on top of the plug in one place (figure 9) to secure the C-seal retainer.
6. Install the new plug/retainer assembly with C-seal plug seal on the new stem following the appropriate instructions in the Trim Replacement section of this manual.
7. Install piston rings by following instructions in the Trim Replacement section of this manual.
8. Remove the existing valve actuator and bonnet following the appropriate instructions in the Replacing Packing section of this manual.

## CAUTION

**Do not remove the existing valve stem from the valve plug unless you are planning to replace the valve stem.**

**Never reuse an old valve stem with a new plug or reinstall a valve stem after it has been removed. Replacing a valve stem requires drilling a new pin hole in the stem. This drilling weakens the stem and may cause failure in service. However, a used valve plug may be reused with a new valve stem.**

9. Remove the existing valve stem and plug, cage, and seat ring from the valve body following the appropriate instructions in the Trim Removal section of this manual.
10. Replace all gaskets according to appropriate instructions in the Trim Replacement section of this manual.
11. Install the new seat ring, cage, valve plug/retainer assembly, and stem into the valve body and completely reassemble the valve package following the appropriate instructions in the Trim Replacement section of this manual.

## CAUTION

**To avoid excessive leakage and seat erosion, the valve plug must be initially seated with sufficient force to overcome the resistance of the C-seal plug seal and contact the seat ring. You can correctly seat the valve plug by applying the full actuator load. This force will adequately drive the valve plug to the seat ring, thus giving the C-seal plug seal a predetermined permanent set. Once this is done, the plug/retainer assembly, the cage, and the seat ring become a matched set.**

With full actuator force applied and the valve plug fully seated, align the actuator travel indicator scale with the lower end of valve travel. Refer to the appropriate actuator instruction manual for information on this procedure.

## Replacement of Installed C-seal Trim

### Trim Removal (C-seal Constructions)

1. Remove the valve actuator and bonnet following the appropriate instructions in the Replacing Packing section of this manual.

## CAUTION

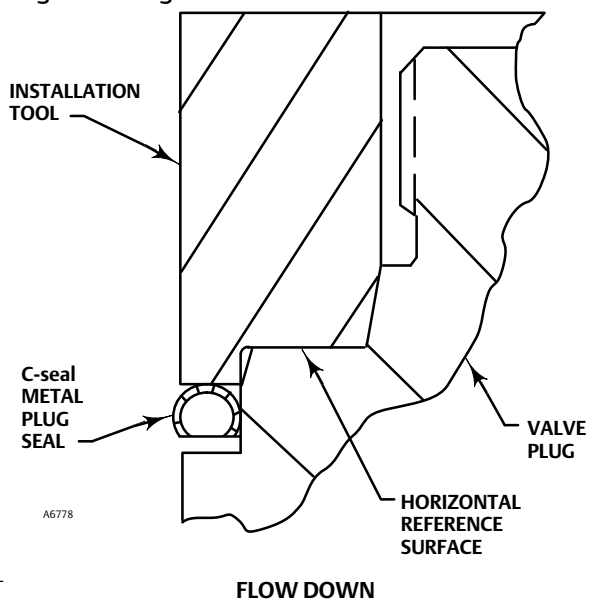
**To avoid leakage when the valve is returned to service, use appropriate methods and materials to protect all sealing surfaces of the trim parts during maintenance.**

**Use caution when removing piston ring(s) and C-seal plug seal to avoid scratching any sealing surface.**



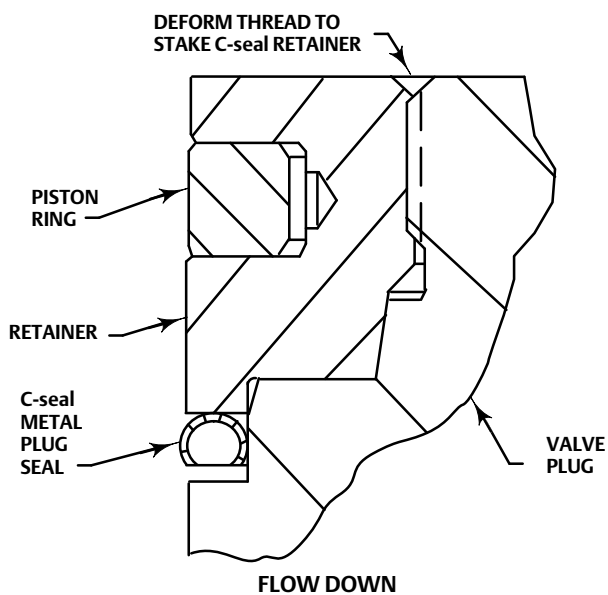


Figure 8. Installing the C-seal Plug Seal Using the Installation Tool



NOTE:  
PRESS INSTALLATION TOOL OVER VALVE PLUG  
UNTIL THE TOOL CONTACTS THE HORIZONTAL  
REFERENCE SURFACE OF THE VALVE PLUG.

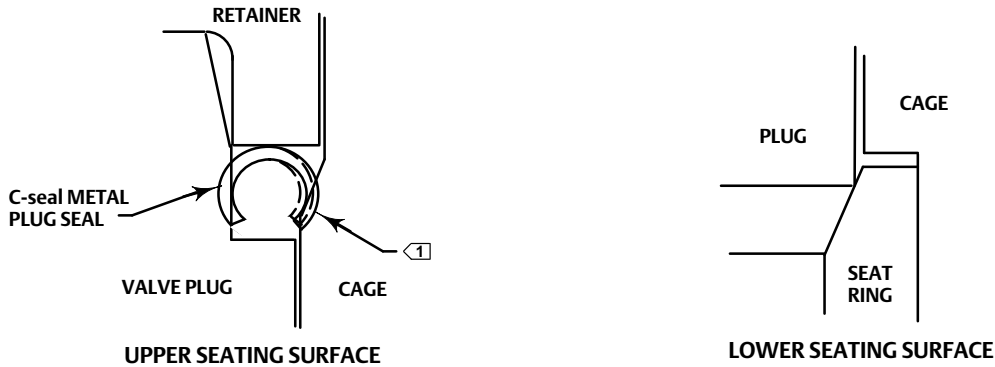
Figure 9. Stake the Threads of the C-seal Retainer



**CAUTION**

Do not remove the valve stem from the plug/retainer assembly unless you are planning to replace the valve stem. Never reuse an old valve stem with a new plug or reinstall a valve stem after it has been removed. Replacing a valve stem requires drilling a new pin hole in the stem. This drilling weakens the stem and may cause failure in service. However, a used valve plug may be reused with a new valve stem.

Figure 10. Lower (Valve Plug to Seat Ring) and Upper (C-seal Plug Seal to Cage) Seating Surfaces

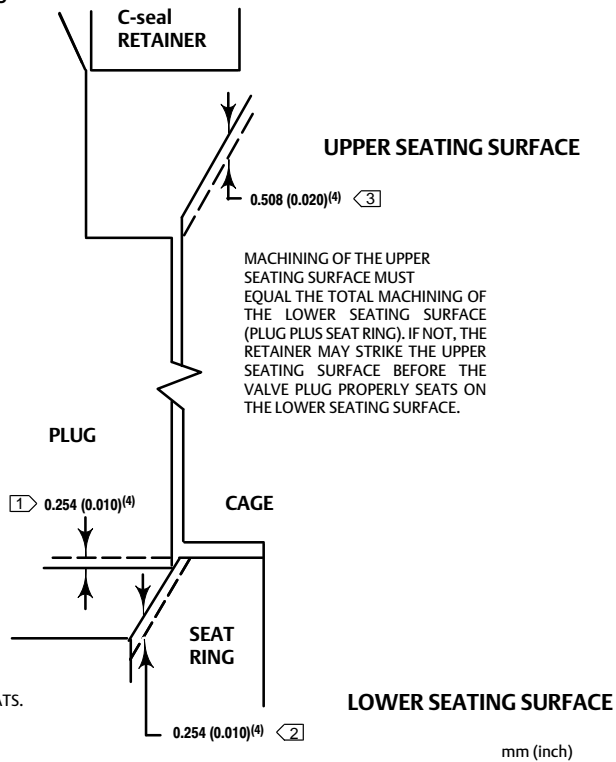


A6780

NOTE:

1 UPPER SEATING SURFACE IS THE AREA OF CONTACT BETWEEN THE C-seal METAL PLUG SEAL AND THE CAGE.

Figure 11. Example of Machining the Lower (Valve Plug to Seat Ring) and Upper (C-seal Plug Seal to Cage) Seating Surfaces



NOTE:

- 1 REMOVAL OF 0.254 mm (0.010 inch) FROM THE VALVE PLUG
- PLUS 2 REMOVAL OF 0.254 mm (0.010 inch) FROM THE SEAT RING
- MUST EQUAL 3 REMOVAL OF 0.508 mm (0.020 inch) FROM THE UPPER SEATING SURFACE IN THE CAGE
- 4. THESE VALUES ARE FOR EXAMPLE ONLY. REMOVE ONLY THE MINIMUM AMOUNT OF MATERIAL REQUIRED TO REFURBISH THE SEATS.

A6781 / IL

mm (inch)

2. Remove the plug/retainer assembly (with C-seal plug seal), cage, and seat ring from the valve body following the appropriate instructions in the Trim Removal section of this manual.
3. Locate the staked thread on top of the valve plug (figure 9). The staked thread secures the retainer. Use a drill with a 1/8 inch bit to drill out the staked area of the thread. Drill approximately 3 mm (1/8 inch) into the metal to remove the staking.
4. Locate the break between sections of the piston ring(s). Using an appropriate tool such as a flat-blade screwdriver, carefully pry out the piston ring(s) from the groove(s) in the C-seal retainer.

5. After removing the piston ring(s), locate the 1/4-inch diameter hole in the groove. In a retainer with two piston ring grooves, the hole will be found in the upper groove.
6. Select an appropriate tool such as a punch and place the tip of the tool into the hole with the body of the tool held tangent to the outside diameter of the retainer. Strike the tool with a hammer to rotate the retainer and free it from the valve plug. Remove the retainer from the plug.
7. Use an appropriate tool such as a flat-blade screwdriver to pry the C-seal plug seal off the plug. Use caution to avoid scratches or other damage to the sealing surfaces where the C-seal plug seal makes contact with the valve plug (figure 10).
8. Inspect the lower seating surface where the valve plug contacts the seat ring for wear or damage which would prevent proper operation of the valve. Also, inspect the upper seating surface inside the cage where the C-seal plug seal contacts the cage, and inspect the sealing surface where the C-seal plug seal makes contact with the plug (figure 10).
9. Replace or repair trim parts according to the following procedure for Lapping Metal Seats, Remachining Metal Seats, or other valve plug maintenance procedures as appropriate.

### Lapping Metal Seats (C-seal Constructions)

Before installing a new C-seal plug seal, lap the lower seating surface (valve plug to seat ring, figure 10) following appropriate procedures in the Lapping Metal Seats section of this manual.

### Remachining Metal Seats (C-seal Constructions)

See figure 11. A valve plug with a C-seal metal plug seal features two seating surfaces. One seating surface is found where the valve plug contacts the seat ring. The second seating surface is found where the C-seal plug seal contacts the upper seating surface in the cage. If you machine the seats on the seat ring and/or plug, you must machine an equal dimension from the seating area in the cage.

## CAUTION

**If metal is removed from the seat ring and plug and a corresponding amount is not removed from the cage seating area, the C-seal plug seal will be crushed as the valve closes and the C-seal retainer will strike the seating area of the cage, preventing the valve from closing.**

---

### Trim Replacement (C-seal Constructions)

1. Apply a suitable high-temperature lubricant to the inside diameter of the C-seal plug seal. Also, lubricate the outside diameter of the valve plug where the C-seal plug seal must be pressed into the proper sealing position (figure 6).
2. Orient the C-seal plug seal for correct sealing action based on the process fluid flow direction through the valve.
  - The open interior of the C-seal plug seal must face up in a valve with flow-up construction (figure 6).
  - The open interior of the C-seal plug seal must face down in a valve with flow-down construction (figure 6).

---

#### Note

An installation tool must be used to properly position the C-seal plug seal on the valve plug. A tool is available as a Fisher spare part or a tool could be manufactured following the dimensions given in figure 7.

---

3. Place the C-seal plug seal over the top of the valve plug and press it onto the plug using the installation tool. Carefully press the C-seal plug seal onto the plug until the installation tool contacts the horizontal reference surface of the valve plug (figure 8).

4. Apply a suitable high-temperature lubricant to the threads on the plug. Then, place the C-seal retainer onto the plug and tighten the retainer using an appropriate tool such as a strap wrench.
5. Using an appropriate tool such as a center punch, stake the threads on top of the plug in one place (figure 9) to secure the C-seal retainer.
6. Replace the piston ring(s) following instructions in the Trim Replacement section of this manual.
7. Return the seat ring, cage, plug/retainer assembly, and stem to the valve body and completely reassemble the valve package following the appropriate instructions in the Trim Replacement section of this manual.

## CAUTION

**To avoid excessive leakage and seat erosion, the valve plug must be initially seated with sufficient force to overcome the resistance of the C-seal plug seal and contact the seat ring. You can correctly seat the valve plug by applying the full actuator load. This force will adequately drive the valve plug to the seat ring, thus giving the C-seal plug seal a predetermined permanent set. Once this is done, the plug/retainer assembly, the cage, and the seat ring become a matched set.**

With full actuator force applied and the valve plug fully seated, align the actuator travel indicator scale with the lower end of valve travel. Refer to the appropriate actuator instruction manual for information on this procedure.

## ENVIRO-SEAL Bellows Seal Bonnet

### Replacing a Plain or Extension Bonnet with an ENVIRO-SEAL Bellows Seal Bonnet (Stem/Bellows Assembly)

1. Remove the actuator and bonnet according to steps 1 through 5 of the Replacing Packing procedure in the Maintenance section.
2. Lift out the cage.
3. Remove and discard the existing bonnet gasket. Cover the valve body opening to protect sealing surfaces and to prevent foreign material from entering the valve body cavity.

#### Note

The ENVIRO-SEAL stem/bellows assembly for easy-e valves is available only with a threaded and drilled plug/adaptor/stem connection. The existing valve plug can be reused with the new stem/bellows assembly or a new plug can be installed.

4. Inspect the existing valve plug. If the plug is in good condition, it can be reused with the new ENVIRO-SEAL stem/bellows assembly. To remove the existing valve plug from the stem, first, place the existing plug stem assembly in a soft-jaw chuck or other type of vise so that the jaws grip a portion of the valve plug that is not a seating surface. Drive out or drill out the pin (key 8).
5. Then, reverse the plug stem assembly in the soft-jaw chuck or vise. Grip the valve stem in an appropriate place and unscrew the existing plug from the valve stem.

## CAUTION

**When installing a valve plug on the ENVIRO-SEAL stem/bellows assembly, the valve stem must not be rotated. Damage to the bellows may result.**

**Do not grip the bellows shroud or other parts of the stem/bellows assembly. Grip only the flat areas on the stem where it extends out of the top of the bellows shroud.**

**Note**

The ENVIRO-SEAL stem/bellows assembly has a one-piece stem.

6. To attach the valve plug to the stem of the new ENVIRO-SEAL stem/bellows assembly, it is necessary to first attach the plug to the adaptor (key 24). Locate the adaptor. Notice that a hole has not been drilled in the threads where the plug screws onto the adaptor. Secure the valve plug in a soft-jaw chuck or other type of vise. Do not grip the plug on any seating surface. Position the plug in the chuck or vise for easy threading of the adaptor. Thread the adaptor into the valve plug and tighten to the appropriate torque value.
7. Select the proper size of drill bit and drill through the adaptor using the hole in the valve plug as a guide. Remove any metal chips or burrs and drive in a new pin (key 8, figures 19, 20, and 21) to lock the plug/adaptor assembly together.
8. Attach the plug/adaptor assembly to the ENVIRO-SEAL stem/bellows assembly by first securing the stem/bellows assembly in a soft-jaw chuck or other type of vise so that the jaws of the chuck or vise grip the flats of the stem extending out of the top of the bellows shroud. Screw the valve plug/adaptor assembly onto the valve stem. Tighten the plug/adaptor assembly until it is snug. Then turn the plug/adaptor assembly to the next pin hole in the valve stem. Drive in new pin (key 36, figure 18) to lock the assembly.
9. Inspect the seat ring (key 9). Replace, if necessary.

Table 6. Recommended Torque for ENVIRO-SEAL Bellows Seal Bonnet Packing Flange Nuts

VALVE SIZE, NPS	VALVE STEM DIAMETER THROUGH PACKING	MINIMUM TORQUE		MAXIMUM TORQUE	
		N•m	Lbf•in	N•m	Lbf•in
1/2 - 2	1/2	2	22	4	33
3 - 8	1	5	44	8	67

10. Place a new gasket (key 10) into the valve body in place of the bonnet gasket. Install the new stem/bellows assembly with valve plug/adaptor by placing it into the valve body on top of the new bellows gasket.
11. Place a new gasket (key 22) over the stem/bellows assembly. Place the new ENVIRO-SEAL bonnet over the stem/bellows assembly.

**Note**

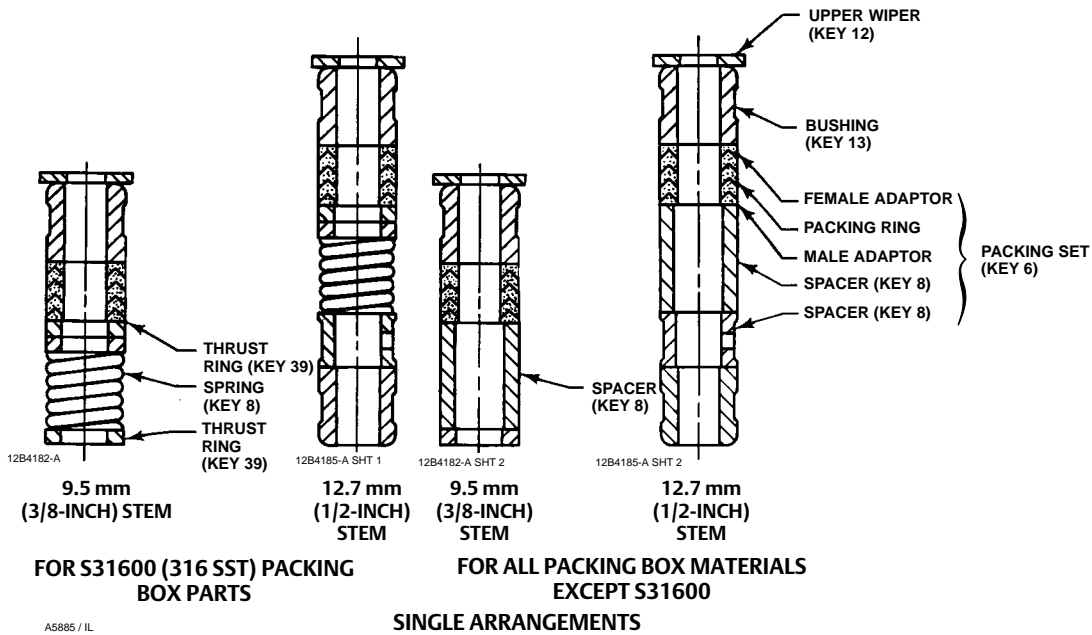
Stud(s) and nut(s) should be installed such that the manufacturer's trademark and material grade marking is visible, allowing easy comparison to the materials selected and documented in the Emerson/Fisher serial card provided with this product.

**⚠ WARNING**

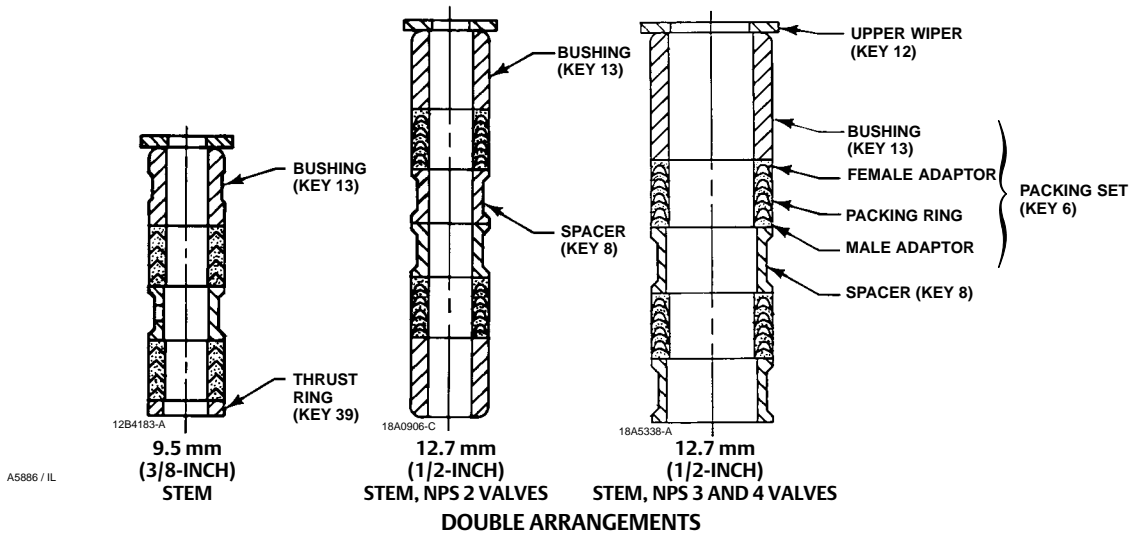
Personal injury or damage to equipment could occur if improper stud and nut materials or parts are used. Do not operate or assemble this product with stud(s) and nut(s) that are not approved by Emerson/Fisher engineering and/or listed on the serial card provided with this product. Use of unapproved materials and parts could lead to stresses exceeding the design or code limits intended for this particular service. Install studs with the material grade and manufacturer's identification mark visible. Contact your [Emerson sales office](#) or Local Business Partner immediately if a discrepancy between actual parts and approved parts is suspected.

12. Properly lubricate the bonnet stud bolts. Install and tighten the bonnet hex nuts to the proper torque.
13. Install the new packing and the metal packing box parts according to the appropriate arrangement in figure 12 or 13.

Figure 12. PTFE Packing Arrangement for Use in ENVIRO-SEAL Bellows Seal Bonnets



A5885 / IL



A5886 / IL

14. Install the packing flange. Properly lubricate the packing flange stud bolts and the faces of the packing flange nuts.

For **graphite packing**, tighten the packing flange nuts to the maximum recommended torque shown in table 6. Then, loosen the packing flange nuts, and retighten them to the recommended minimum torque shown in table 6.

For **other packing types**, tighten the packing flange nuts alternately in small equal increments until one of the nuts reaches the minimum recommended torque shown in table 6. Then, tighten the remaining flange nut until the packing flange is level and at a 90-degree angle to the valve stem.

15. Install the travel indicator parts and stem locknuts; mount the actuator on the valve body according to the procedure in the appropriate actuator instruction manual.

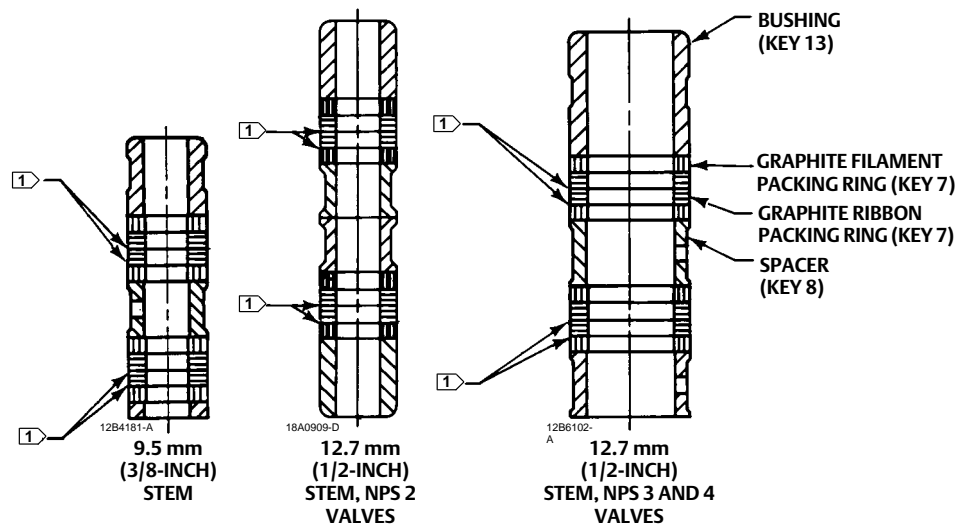
### Replacement of an Installed ENVIRO-SEAL Bellows Seal Bonnet (Stem/Bellows Assembly)

1. Remove the actuator and bonnet according to steps 1 through 5 of the Replacing Packing procedure of the Maintenance section.
2. Lift out the cage. Remove and discard the existing bonnet gasket and bellows gasket. Cover the valve body opening to protect sealing surfaces and to prevent foreign material from entering the valve body cavity.

**Note**

The ENVIRO-SEAL stem/bellows assembly for easy-e valves is available only with a threaded and pinned plug/adaptor/stem connection. The existing valve plug can be reused with the new stem/bellows assembly or a new plug can be installed. If the existing valve plug is reused, and the adaptor is in good condition, it may be reused also. However, never reuse an old adaptor with a new valve plug. Using an old adaptor with a new valve plug requires drilling a new pin hole in the adaptor. This drilling weakens the adaptor and may cause failure in service. However, a used valve plug may be reused with a new adaptor.

Figure 13. Double Graphite Ribbon/Filament Arrangements for Use in ENVIRO-SEAL Bellows Seal Bonnets



A5887

NOTES:  
 1 > 0.102 mm (0.004 INCH) THICK SACRIFICIAL ZINC WASHERS;  
 USE ONLY ONE BELOW EACH GRAPHITE RIBBON RING.

3. Inspect the existing valve plug and adaptor. If they are in good condition, they can be reused with the new stem/bellows assembly and they do not need to be separated.

**CAUTION**

When removing/installing a valve plug on the ENVIRO-SEAL stem/bellows assembly, the valve stem must not be rotated. Damage to the bellows may result.

Do not grip the bellows shroud or other parts of the stem/bellows assembly. Grip only the flat areas on the stem where it extends out of the top of the bellows shroud.

**Note**

The ENVIRO-SEAL stem/bellows assembly has a one-piece stem.

4. If the valve plug and adaptor are not in good condition and must be replaced, the valve plug/adaptor assembly must first be removed from the stem/bellows assembly and then the valve plug removed from the adaptor. First, place the stem/bellows assembly and valve plug in a soft-jaw chuck or other type of vise so that the jaws grip a portion of the valve plug that is not a seating surface. Drive out or drill out the pin (key 8, figure 19, 20, or 21). Drive out the pin (key 36, figure 18).
5. Then, reverse the stem/bellows and plug/adaptor assembly in the soft-jaw chuck or vise. Grip the flat areas on the valve stem just below the threads for the actuator/stem connection. Unscrew the plug/adaptor assembly from the stem/bellows assembly. Unscrew the valve plug from the adaptor.
6. To attach either the existing or a new valve plug to the stem of the new ENVIRO-SEAL stem/bellows assembly, first attach the plug to the adaptor (if the valve plug was removed from the adaptor) as follows:
  - a. Locate the adaptor. Notice that a hole has not been drilled in the new adaptor threads where the plug screws onto the adaptor.
  - b. Secure the valve plug in a soft-jaw chuck or other type of vise. Do not grip the plug on any seating surface. Position the plug in the chuck or vise for easy threading of the adaptor.
  - c. Thread the adaptor into the valve plug and tighten to the appropriate torque value.
7. Complete the installation by following steps 7 through 15 of the ENVIRO-SEAL Bellows Seal Bonnet installation instructions given above.

## Purging the ENVIRO-SEAL Bellows Seal Bonnet

The ENVIRO-SEAL bellows seal bonnet has been designed so that it can be purged or leak tested. Refer to figure 18 for an illustration of an ENVIRO-SEAL bellows seal bonnet. Perform the following steps for purging or leak testing.

1. Remove the two diametrically opposed pipe plugs (key 16).
2. Connect a purging fluid to one of the pipe plug connections.
3. Install appropriate piping or tubing in the other pipe plug connection to pipe away the purging fluid or to make a connection to an analyzer for leak testing.
4. When purging or leak testing has been completed, remove the piping or tubing and reinstall the pipe plugs (key 16).

## Parts Ordering

Each valve body-bonnet assembly is assigned a serial number which can be found on the valve. This same number also appears on the actuator nameplate when the valve is shipped from the factory as part of a control valve assembly. Refer to the serial number when contacting your [Emerson sales office](#) or Local Business Partner for technical assistance. When ordering replacement parts, refer to the serial number and to the eleven-character part number for each part required from the following Parts Kit or Parts List information.

### **⚠ WARNING**

**Use only genuine Fisher replacement parts. Components that are not supplied by Emerson Automation Solutions should not, under any circumstances, be used in any Fisher valve, because they may void your warranty, might adversely affect the performance of the valve, and could cause personal injury and property damage.**



## Parts Kits

### Note

Kits do not apply to N10276, N08020, or N04400 trims.

## Gasket Kits

Gasket Kits (includes keys 10, 12, 13, and 51; plus 11, 14, and 20 on some restricted capacity valves)

DESCRIPTION	Standard Trim Cage Whisper Trim I Cage Cavitrol III - 1 Stage Cage	Cavitrol III - 2 Stage Cage Whisper Trim III Cage WhisperFlo Cage
	-198 to 593° C (-325 to 1100° F)	
Full Capacity Valves	Part Number	Part Number
NPS 1 & 1-1/4 (NPS 1 EAD)	RGASKETX162	RGASKETX422
NPS 1-1/2 (NPS 2 EAD)	RGASKETX172	RGASKETX432
NPS 2	RGASKETX182	RGASKETX442
NPS 2-1/2 (NPS 3 EAD)	RGASKETX192	RGASKETX452
NPS 3 (NPS 4 EAD)	RGASKETX202	RGASKETX462
NPS 4 (NPS 6 EAD)	RGASKETX212	RGASKETX472
NPS 6	RGASKETX222	RGASKETX482
NPS 8	RGASKETX232	10A3265X152
Restricted Capacity Valves		
NPS 1-1/2 x 1 (NPS 2 x 1 EAD)	RGASKETX242	---
NPS 2 x 1	RGASKETX252	---
NPS 2-1/2 x 1-1/2 (NPS 3 x 1-1/2 EAD)	RGASKETX262	---
NPS 3 x 2 (NPS 4 x 2 EAD)	RGASKETX272	---
NPS 4 x 2-1/2 (NPS 6 x 2-1/2 EAD)	RGASKETX282	---

## Packing Kits

Standard Packing Repair Kits (Non Live-Loaded)

REPAIR KIT MATERIAL	STEM DIAMETER, mm (INCH) YOKE BOSS DIAMETER, mm (INCH)				
	9.5 (3/8) 54 (2-1/8)	12.7 (1/2) 71 (2-13/16)	19.1 (3/4) 90 (3-9/16)	25.4 (1) 127 (5)	31.8 (1-1/4) 127 (5, 5H)
	Part Number				
PTFE (Contains keys 6, 8, 10, 11, and 12)	RPACKX00012	RPACKX00022	RPACKX00032	RPACKX00342	RPACKX00352
Double PTFE (Contains keys 6, 8, 11, and 12)	RPACKX00042	RPACKX00052	RPACKX00062	RPACKX00362	RPACKX00372
PTFE/Composition (Contains keys 7, 8, 11, and 12)	RPACKX00072	RPACKX00082	RPACKX00092	---	---
Single Graphite Ribbon/Filament (Contains keys 7 [ribbon ring], 7 [filament ring], 8, and 11)	RPACKX00102	RPACKX00112	RPACKX00122	---	---
Single Graphite Ribbon/Filament (Contains keys 7 [ribbon ring], 7 [filament ring], and 11)	---	---	---	RPACKX00532	RPACKX00542
Single Graphite Ribbon/Filament (Contains keys 7 [ribbon ring], 7 [filament ring])	RPACKX00132	RPACKX00142	RPACKX00152	---	---
Double Graphite Ribbon/Filament (Contains keys 7 [ribbon ring], 7 [filament ring], 8, and 11)	RPACKX00162	RPACKX00172	RPACKX00182	---	---

Figure 14. Typical HIGH-SEAL Graphite ULF Packing System

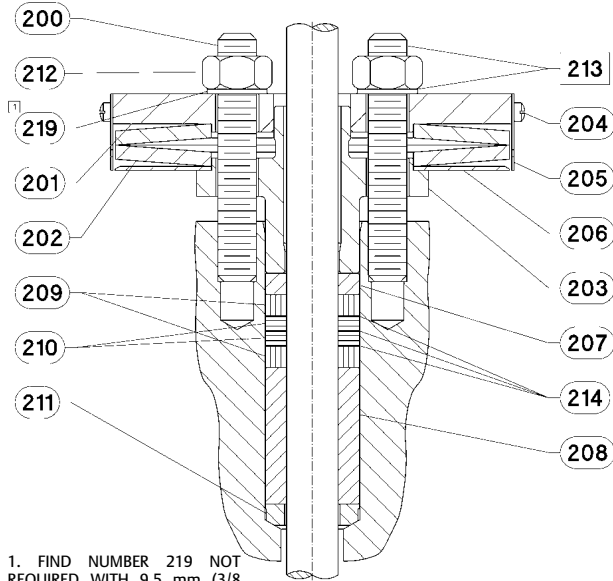


Figure 16. Typical ENVIRO-SEAL Packing System with Graphite ULF Packing

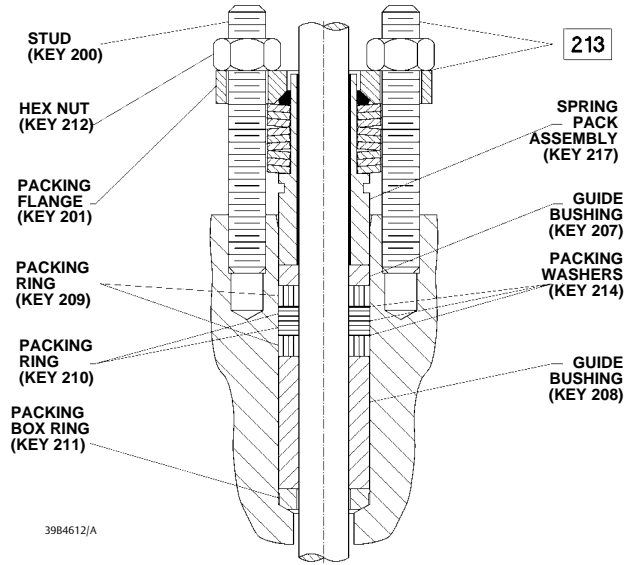


Figure 15. Typical ENVIRO-SEAL Packing System with PTFE Packing

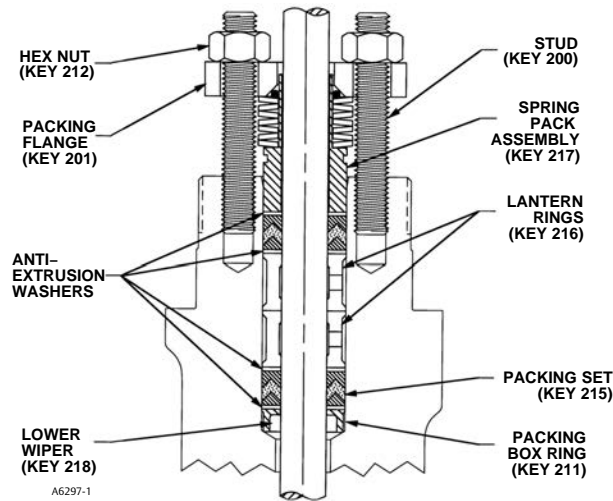
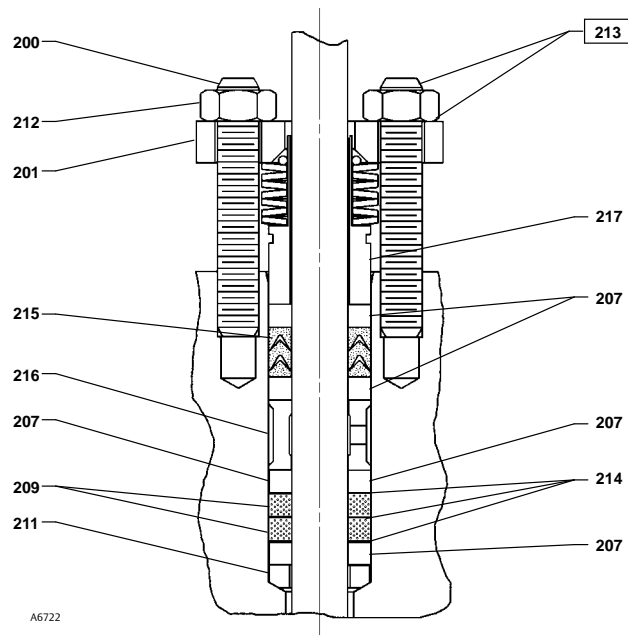


Figure 17. Typical ENVIRO-SEAL Packing System with Duplex Packing



### ENVIRO-SEAL Packing Retrofit Kits

Retrofit kits include parts to convert valves with existing standard bonnets to the ENVIRO-SEAL packing box construction. Refer to figure 15 for key numbers for PTFE packing, figure 16 for key numbers for Graphite ULF packing, and figure 17 for key numbers for duplex packing. PTFE kits include keys 200, 201, 211, 212, 214, 215, 217, 218, tag, and cable tie. Graphite ULF kits include keys 200, 201, 207, 208, 209, 210, 211, 212, 214, 216, 217, tag, and cable tie. Duplex kits include keys 200, 201, 207, 209, 211, 212, 214, 215, 216, 217, tag, and cable tie.

Stems and packing box constructions that do not meet Fisher stem finish specifications, dimensional tolerances, and design specifications, may adversely alter the performance of this packing kit.

For part numbers of individual components, refer to instruction manual ENVIRO-SEAL Packing System for Sliding-Stem Valves, [D101642X012](#).

#### ENVIRO-SEAL Packing Retrofit Kits

PACKING MATERIAL	STEM DIAMETER, mm (INCH) YOKE BOSS DIAMETER, mm (INCH)				
	9.5 (3/8) 54 (2-1/8)	12.7 (1/2) 71 (2-13/16)	19.1 (3/4) 90 (3-9/16)	25.4 (1) 127 (5)	31.8 (1-1/4) 127 (5, 5H)
	Part Number				
Double PTFE	RPACKXRT012	RPACKXRT022	RPACKXRT032	RPACKXRT042	RPACKXRT052
Graphite ULF	RPACKXRT262	RPACKXRT272	RPACKXRT282	RPACKXRT292	RPACKXRT302
Duplex	RPACKXRT212	RPACKXRT222	RPACKXRT232	RPACKXRT242	RPACKXRT252

### ENVIRO-SEAL Packing Repair Kits

Repair kits include parts to replace the "soft" packing materials in valves that already have ENVIRO-SEAL packing arrangements installed or in valves that have been upgraded with ENVIRO-SEAL retrofit kits. Refer to figure 15 for key numbers for PTFE packing, figure 16 for key numbers for Graphite ULF packing, and figure 17 for key numbers for duplex packing. PTFE repair kits include keys 214, 215, and 218. Graphite ULF repair kits include keys 207, 208, 209, 210, and 214. Duplex repair kits include keys 207, 209, 214, and 215.

Stems and packing box constructions that do not meet Fisher stem finish specifications, dimensional tolerances, and design specifications, may adversely alter the performance of this packing kit.

For part numbers of individual components, refer to instruction manual ENVIRO-SEAL Packing System for Sliding-Stem Valves, [D101642X012](#).

#### ENVIRO-SEAL Packing Repair Kits

PACKING MATERIAL	STEM DIAMETER, mm (INCH) YOKE BOSS DIAMETER, mm (INCH)				
	9.5 (3/8) 54 (2-1/8)	12.7 (1/2) 71 (2-13/16)	19.1 (3/4) 90 (3-9/16)	25.4 (1) 127 (5)	31.8 (1-1/4) 127 (5, 5H)
	Part Number				
Double PTFE (contains keys 214, 215, & 218)	RPACKX00192	RPACKX00202	RPACKX00212	RPACKX00222	RPACKX00232
Graphite ULF (contains keys 207, 208, 209, 210, and 214)	RPACKX00592	RPACKX00602	RPACKX00612	RPACKX00622	RPACKX00632
Duplex (contains keys 207, 209, 214, and 215)	RPACKX00292	RPACKX00302	RPACKX00312	RPACKX00322	RPACKX00332

**easy-e Low-e Bonnet Repair Kits**

Kit consists of plain bonnet, Graphite / Inconel gasket set, ENVIRO-SEAL packing retro-fit kit, packing flange, packing flange studs and nuts. New stem is not included.

Bonnet Material	Packing Type	Valve Size, NPS	Stem Size	Part Number		
WCC <sup>(1)</sup>	ENVIRO-SEAL PTFE	0.5-1.25	3/8"	RLEPBNTX012		
		1.5	3/8"	RLEPBNTX022		
		2	1/2"	RLEPBNTX032		
		2.5	1/2"	RLEPBNTX042		
		3	1/2"	RLEPBNTX052		
		4	1/2"	RLEPBNTX062		
		6	3/4"	RLEPBNTX072		
	ENVIRO-SEAL Graphite ULF	0.5-1.25	3/8"	RLEPBNTX152		
		1.5	3/8"	RLEPBNTX162		
		2	1/2"	RLEPBNTX172		
		2.5	1/2"	RLEPBNTX182		
		3	1/2"	RLEPBNTX192		
		4	1/2"	RLEPBNTX202		
		6	3/4"	RLEPBNTX212		
SST <sup>(1)</sup>	ENVIRO-SEAL PTFE	0.5-1.25	3/8"	RLEPBNTX082		
		1.5	3/8"	RLEPBNTX092		
		2	1/2"	RLEPBNTX102		
		2.5	1/2"	RLEPBNTX112		
		3	1/2"	RLEPBNTX122		
		4	1/2"	RLEPBNTX132		
	ENVIRO-SEAL Graphite ULF	0.5-1.25	3/8"	RLEPBNTX222		
		1.5	3/8"	RLEPBNTX232		
		2	1/2"	RLEPBNTX242		
		2.5	1/2"	RLEPBNTX252		
		3	1/2"	RLEPBNTX262		
		4	1/2"	RLEPBNTX272		
		WCC	ENVIRO-SEAL Duplex	0.5-1.25	3/8"	RLEPBNTX292
				1.5	3/8"	RLEPBNTX302
2	1/2"			RLEPBNTX322		
2.5	1/2"			RLEPBNTX332		
3	1/2"			RLEPBNTX342		
4	1/2"			RLEPBNTX352		
6	3/4"			RLEPBNTX362		
SST	ENVIRO-SEAL Duplex	0.5-1.25	3/8"	RLEPBNTX372		
		1.5	3/8"	RLEPBNTX392		
		2	1/2"	RLEPBNTX412		
		2.5	1/2"	RLEPBNTX422		
		3	1/2"	RLEPBNTX432		
		4	3/4"	RLEPBNTX442		

1. Compliant with NACE MR0175-2003 and prior, NACE MR0175 / ISO 15156 (all revisions), and NACE MR0103 (all revisions).

## Parts List

**Note**

Part numbers are shown for recommended spares only. For part numbers not shown, contact your [Emerson sales office](#) or Local Business Partner.

### Bonnet (figure 18)

**Key Description**

- 1 Bonnet  
If you need a bonnet and/or an ENVIRO-SEAL bellows seal bonnet as a replacement part, order by valve size and stem diameter, serial number, and desired material.
- 2 Extension Bonnet Baffle
- 3 Packing Flange
- 3 ENVIRO-SEAL bellows seal packing flange
- 4 Packing Flange Stud
- 4 ENVIRO-SEAL bellows seal stud bolt
- 5 Packing Flange Nut
- 5 ENVIRO-SEAL bellows seal packing flange nut
- 6\* Packing set, PTFE
- 6\* ENVIRO-SEAL bellows seal packing set
- 7\* Packing Ring, PTFE
- 7\* ENVIRO-SEAL bellows seal packing ring (4 req'd)
- 7\* ENVIRO-SEAL bellows seal packing ring (4 req'd)

**Key Description**

- 8 Spring
- 8 Lantern Ring
- 8 ENVIRO-SEAL bellows seal spring
- 8 ENVIRO-SEAL bellows seal spacer
- 10 Special Washer
- 11\* Packing Box Ring
- 12\* Upper Wiper, felt
- 12\* ENVIRO-SEAL bellows seal upper wiper, felt
- 13 Packing Follower
- 13\* ENVIRO-SEAL bellows seal bushing
- 13\* ENVIRO-SEAL bellows seal bushing/liner
- 14 Pipe Plug, for 1/4 NPT tapping in packing box
- 14 Lubricator
- 14 Lubricator/Isolating Valve
- 15 Yoke Locknut
- 15 ENVIRO-SEAL bellows seal yoke locknut
- 16 Pipe Plug for 1/2 NPT tapped extension bonnets
- 16 ENVIRO-SEAL bellows seal pipe plug
- 20\* ENVIRO-SEAL bellows seal stem/bellows assembly
- 22\* ENVIRO-SEAL bellows seal bonnet gasket,
- 24 ENVIRO-SEAL bellows seal adaptor
- 25 Cap Screw
- 26 Hex Nut
- 27 Pipe Nipple for lubricator/isolating valve
- 28 Warning Nameplate for ENVIRO-SEAL bellows
- 29 Drive Screw for ENVIRO-SEAL bellows
- 34 Lubricant, anti-seize (not furnished with valve)
- 36\* ENVIRO-SEAL bellows seal pin
- 37 Warning Tag for ENVIRO-SEAL bellows
- 38 Tie for ENVIRO-SEAL bellows
- 39 ENVIRO-SEAL bellows seal thrust ring

## Key Description

**Valve Body (figures 19-24)**

1	Valve Body If you need a valve body as a replacement part, order by valve size, serial number, and desired material.
2*	Valve Plug
3*	Cage
4	Cage Adaptor
5	Seat Ring Adaptor
6*	Piston Ring(s)
7*	Valve Plug Stem
8*	Pin
9*	Seat Ring
9*	EAD liner
10*	Bonnet Gasket
11*	Cage Gasket
12*	Spiral Wound Gasket
13*	Seat Ring Gasket
14*	Adaptor Gasket
15	Cap Screw
15	Stud Bolt
16	Hex Nut

## Key Description

17	Pipe Plug, for use in valves with drain tapping only
18	Flow Direction Arrow
19	Drive Screw
20*	Adaptor Gasket
26	Load Ring
27*	Shim
31*	Whisper Trim III Cage Retainer for Levels A3, B3 & C3 (NPS 6 ED only)
31*	Whisper Trim III Cage Retainer & Baffle Ass'y for Level D3 (NPS 6 ED only)
32	Whisper Trim III Bonnet Spacer
51*	Shim
54	Wire

**C-seal Trim (figure 6)**

2*	Valve Plug/Retainer
3*	Cage
6*	Piston Ring, graphite
7*	Valve Plug Stem
9*	Seat Ring
64*	C-seal



Gaskets and Shims Parts Kits<sup>(7)</sup>

VALVE SIZE, NPS		Standard Trim Cage Whisper Trim I Cage Cavitrol III - 1 Stage Cage	Cavitrol III - 2 Stage Cage Whisper Trim III Cage WhisperFlo Cage	VALVE SIZE, NPS		Standard Trim Cage Whisper Trim I Cage Cavitrol III - 1 Stage Cage	Cavitrol III - 2 Stage Cage Whisper Trim III Cage WhisperFlo Cage
ED	EAD	-198 to 593°C (-325 to 1100°F)		ED	EAD	-198 to 593°C (-325 to 1100°F)	
		Part Number				Part Number	
1 or 1-1/4	1	RGASKETX162 <sup>(1)(2)</sup>	RGASKETX422 <sup>(3)</sup>	3	4	RGASKETX202 <sup>(1)(2)</sup>	RGASKETX462 <sup>(3)</sup>
1-1/2	2	RGASKETX172 <sup>(1)(2)</sup>	RGASKETX432 <sup>(3)</sup>	3 x 2	4 x 2	RGASKETX272 <sup>(1)(4)</sup>	---
1-1/2 x 1	2 x 1	RGASKETX242 <sup>(1)(5)</sup>	---	4	6	RGASKETX212 <sup>(1)(2)</sup>	RGASKETX472 <sup>(3)</sup>
2	---	RGASKETX182 <sup>(2)</sup>	RGASKETX442 <sup>(3)</sup>	4 x 2-1/2	6 x 2-1/2	RGASKETX282 <sup>(1)(4)</sup>	---
2 x 1	---	RGASKETX252 <sup>(4)</sup>	---	6	---	RGASKETX222 <sup>(2)</sup>	RGASKETX482 <sup>(3)</sup>
2-1/2	3	RGASKETX192 <sup>(1)(2)</sup>	RGASKETX452 <sup>(3)</sup>	8	---	RGASKETX232 <sup>(5)</sup>	10A3265X152 <sup>(6)</sup>
2-1/2 x 1-1/2	3 x 1-1/2	RGASKETX262 <sup>(1)(4)</sup>	---				

1. Set number good for both ED and EAD valve.  
 2. Kit includes key 10, 12, 13, 27 or 51  
 3. Kit includes key 10, qty 2; 12; 13; 51  
 4. Kit includes key 10, 11, 12, 13, 14, 27 or 51  
 5. Kit includes key 10 and 13  
 6. Kit includes key 10, qty 2; and 13  
 7. See table below for gasket descriptions

Gasket Descriptions

KEY NUMBER	DESCRIPTION	MATERIAL
		FGM -198° to 593°C (-325° to 1100°F)
10	Bonnet Gasket	Graphite/S31600
11	Cage Gasket	
13	Seat Ring or Liner Gasket	
14 or 20	Adapter Gasket	
12	Spiral-Wound Gasket	N06600/Graphite
27 or 51	Shim	S31600 (316 SST)

Actuator Groups (by Type Number)

Group 1 54 mm (2-1/8 inches), 71 mm (2-13/16 inches) or 90 mm (3-9/16 inches) Yoke Boss	Group 100 127 mm (5 inches) Yoke Boss	Group 403 90.5 mm (3-9/16 inches) Yoke Boss
585C	585C	585C
1B	657	1008
644 & 645	1008	
655		
657 & 667—76.2 mm (3 inches) travel		
1008—71.4 mm (2-13/16 inches) yoke boss		
	<b>Group 101</b> 127 mm (5 inches) Yoke Boss	
	667	



Figure 19. Standard NPS 1 through 6 Fisher ED and EAD Valves

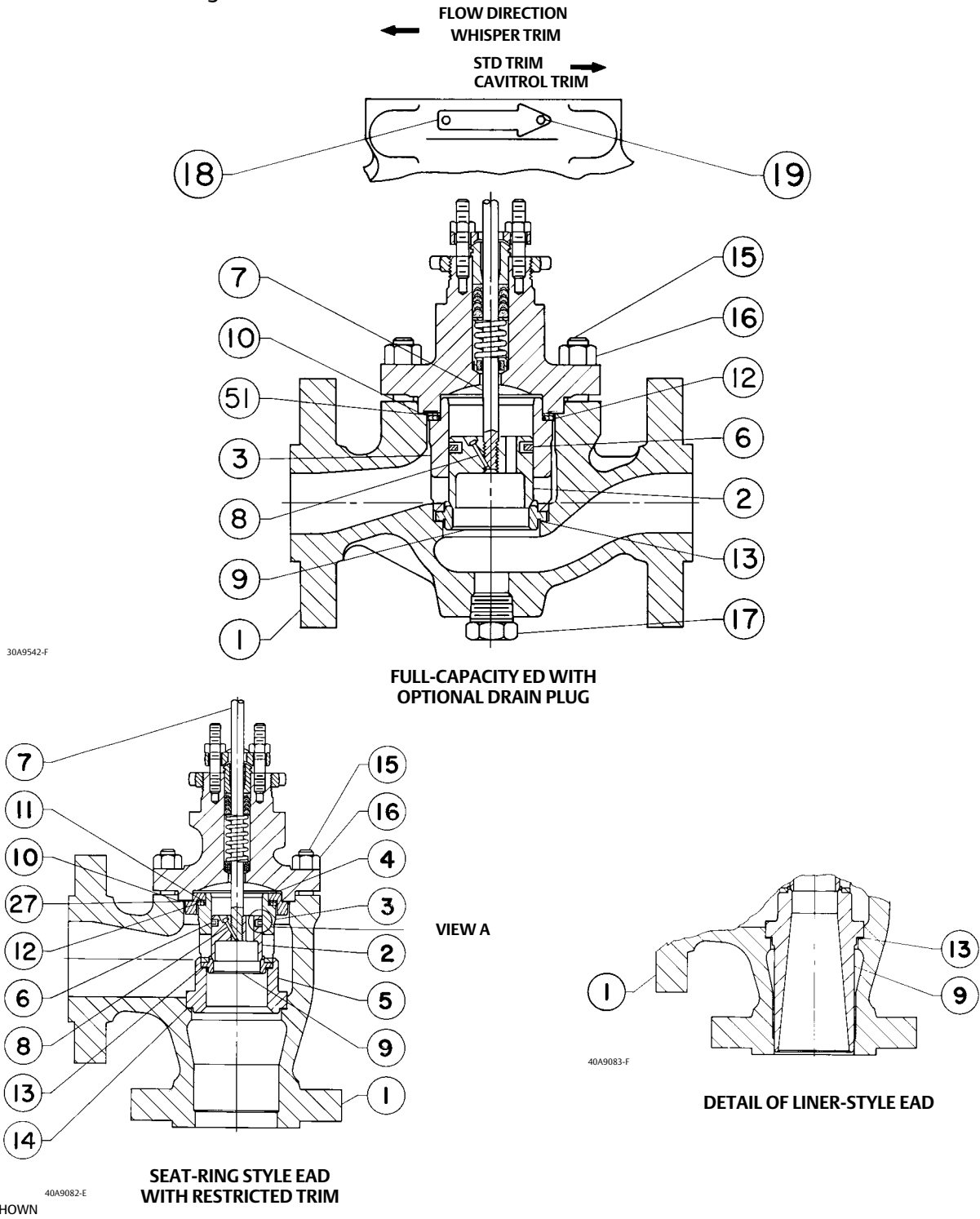


Figure 20. Whisper Trim III Detail with Optional Drain Plug

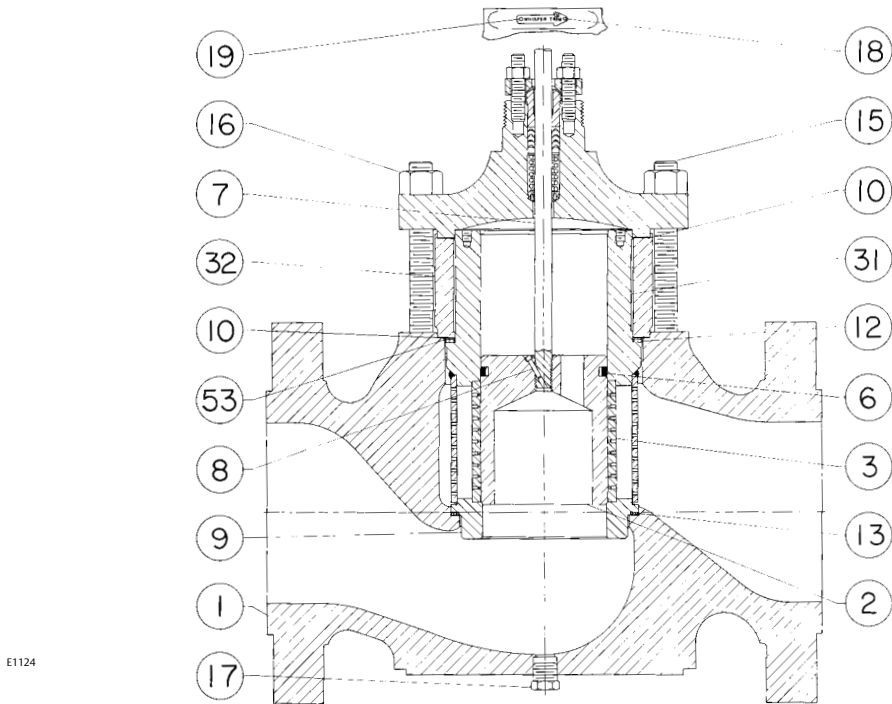


Figure 21. NPS 8 Fisher ED Valve with Graphite Piston Ring and Optional Drain Plug

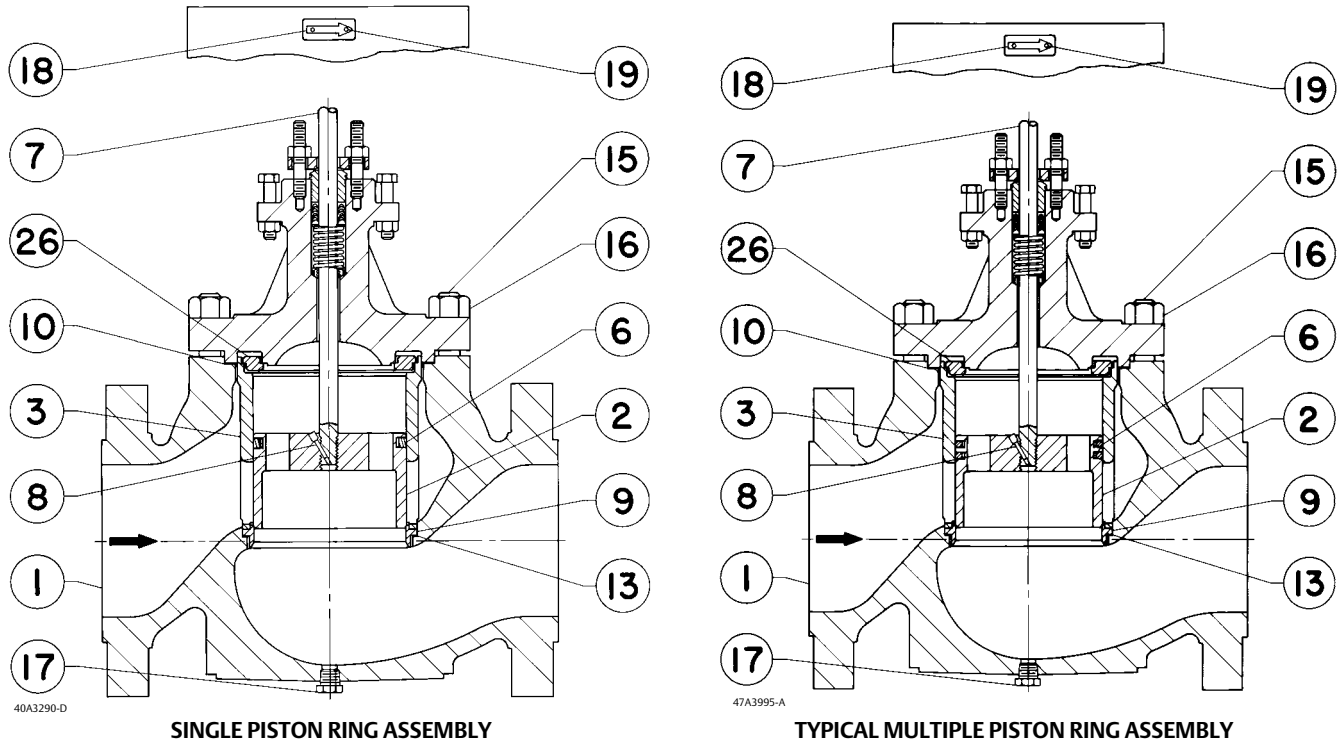
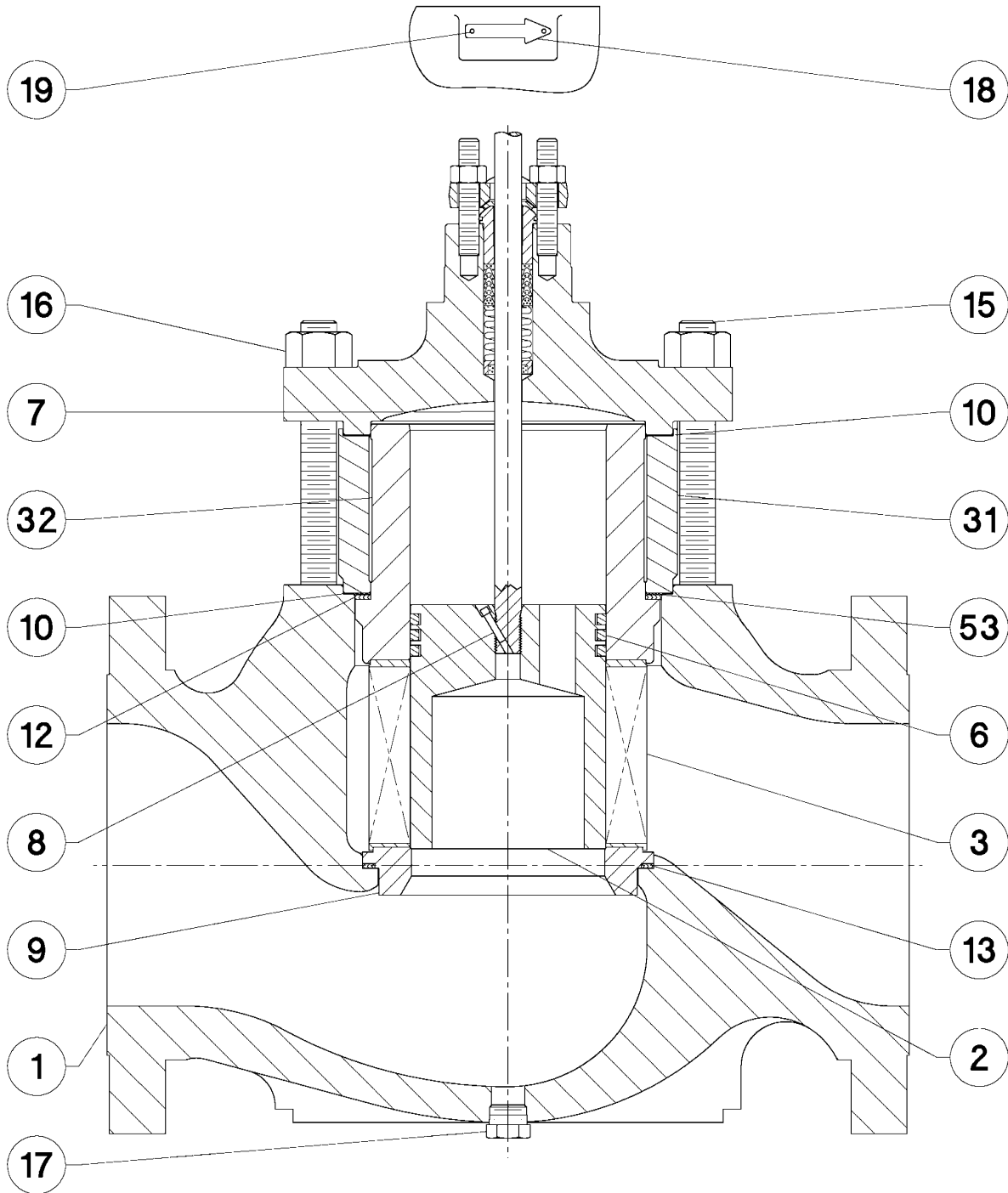
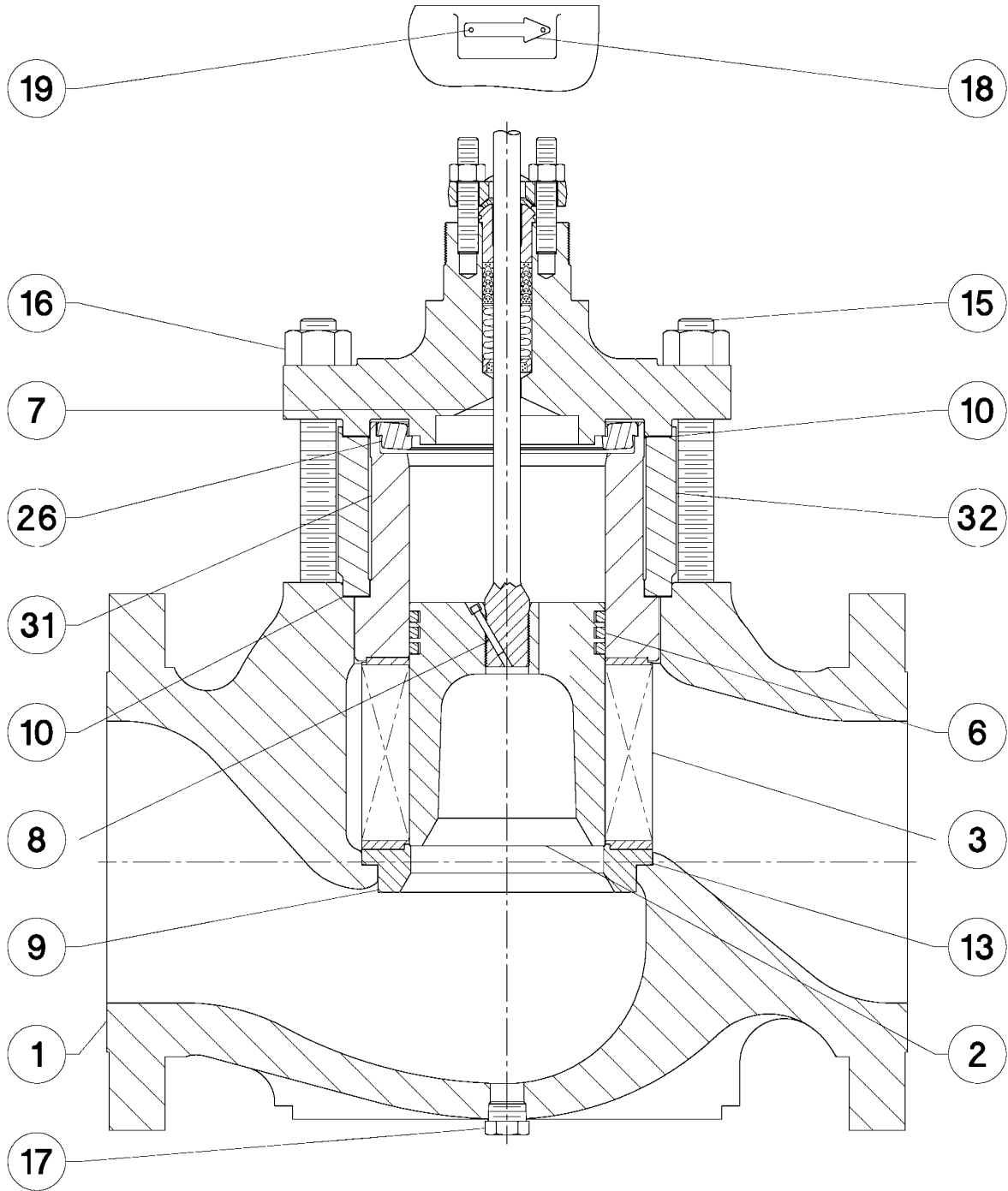


Figure 22. Fisher ED Valve Assembly with WhisperFlo Cage and Optional Drain Plug



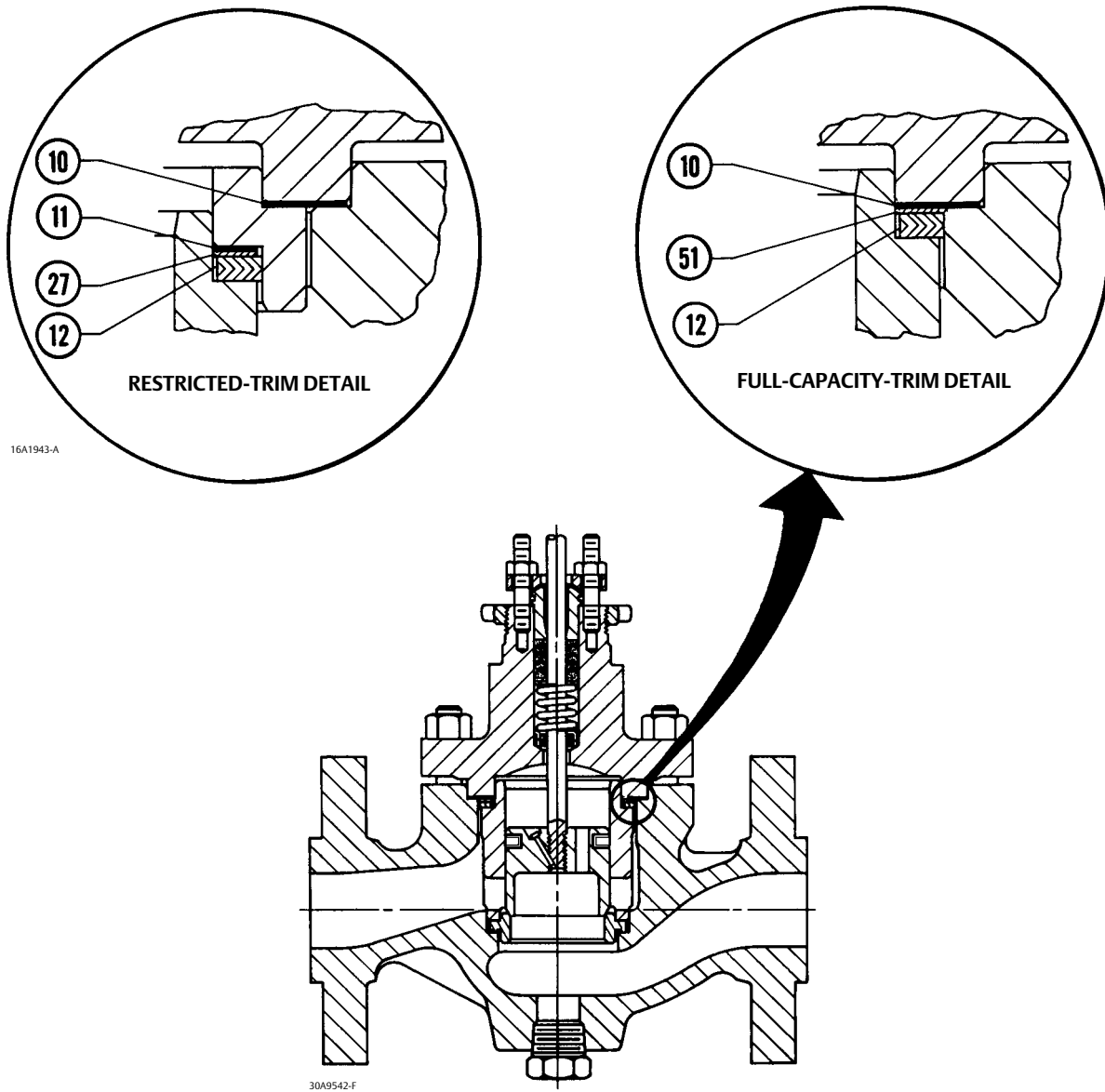
E1125

Figure 23. NPS 8 Fisher ED Valve Assembly with WhisperFlo Cage and Optional Drain Plug



E1123

Figure 24. Gasket Set Detail with Optional Drain Plug







**Neither Emerson, Emerson Automation Solutions, nor any of their affiliated entities assumes responsibility for the selection, use or maintenance of any product. Responsibility for proper selection, use, and maintenance of any product remains solely with the purchaser and end user.**

Fisher, ENVIRO-SEAL, Cavitrol, easy-e, WhisperFlo, and Whisper Trim are marks owned by one of the companies in the Emerson Automation Solutions business unit of Emerson Electric Co. Emerson Automation Solutions, Emerson, and the Emerson logo are trademarks and service marks of Emerson Electric Co. All other marks are the property of their respective owners.

The contents of this publication are presented for informational purposes only, and while every effort has been made to ensure their accuracy, they are not to be construed as warranties or guarantees, express or implied, regarding the products or services described herein or their use or applicability. All sales are governed by our terms and conditions, which are available upon request. We reserve the right to modify or improve the designs or specifications of such products at any time without notice.

**Emerson Automation Solutions**  
Marshalltown, Iowa 50158 USA  
Sorocaba, 18087 Brazil  
Cernay 68700 France  
Dubai, United Arab Emirates  
Singapore 128461 Singapore

[www.Fisher.com](http://www.Fisher.com)

