

# Fisher™ FIELDVUE™ DLC3010 Digital Level Controller

This manual applies to:

Device Type	DLC3010
Device Revision	1
Hardware Revision	1
Firmware Revision	8
DD Revision	3

## Contents

<b>Section 1 Introduction and Specifications</b>	<b>3</b>
Scope of Manual	3
Conventions Used in this Manual	3
Description	3
Specifications	4
Related Documents	5
Educational Services	5
<b>Section 2 Installation</b>	<b>13</b>
Configuration: On the Bench or in the Loop	13
Protecting the Coupling and Flexures	13
Mounting	15
Hazardous Area Classifications and Special Instructions for “Safe Use” and Installations in Hazardous Locations	15
Mounting the 249 Sensor	15
Digital Level Controller Orientation	16
Mounting the Digital Level Controller on a 249 Sensor	18
Mounting the Digital Level Controller for High Temperature Applications	18
Electrical Connections	20
Power Supply	20
Field Wiring	21
Grounding	22
Shielded Wire	22
Power/Current Loop Connections	23
RTD Connections	23
Two-Wire RTD Connections	23
Three-Wire RTD Connections	23
Communication Connections	23
Test Connections	24
Multichannel Installations	24



W7977-2

Alarm Jumper	25
Changing Jumper Position	26
Loop Test	26
Installation in Conjunction with a Rosemount 333 HART Tri-Loop™ HART-to-Analog Signal Converter	27
Multidrop Communication	95
<b>Section 3 Overview</b>	<b>29</b>
<b>Section 4 Setup and Calibration</b>	<b>33</b>
Initial Setup	33
Configuration Advice	34
Preliminary Considerations	34
Write Lock	34
Guided Setup	34
Coupling	38
Manual Setup	39
Sensor	39
Variables	41
Process Fluid	43
Device Information	47
Instrument Display	47
Alert Setup	49
Primary Variable	49
Temperature	51

Communications ..... 53  
 Burst Mode ..... 53  
 Burst Option ..... 53  
 Calibration ..... 54  
 Introduction: Calibration of Smart Instruments .. 54  
 Primary ..... 54  
   Guided Calibration ..... 54  
   Full Calibration ..... 55  
     Min/Max Calibration ..... 55  
     Two Point Calibration ..... 55  
     Weight Calibration ..... 56  
   Theoretical Calibration ..... 56  
   Partial Calibration ..... 57  
     Capture Zero ..... 57  
     Trim Gain ..... 57  
     Trim Zero ..... 58  
 Secondary ..... 58  
   Temperature Calibration ..... 58  
     Trim Instrument Temperature ..... 58  
     Trim Process Temperature ..... 58  
   Manual Entry of Process Temperature ..... 59  
   Analog Output Calibration ..... 59  
     Scaled D/A Trim ..... 59  
 Calibration Examples ..... 60  
   Calibration with Standard displacer and  
   Torque Tube ..... 60  
   Calibration with Overweight Displacer ..... 61  
   Density Applications - with Standard Displacer  
   and Torque Tube ..... 63  
   Calibration at Process Conditions (Hot Cut-Over)  
   when input cannot be varied ..... 63  
   Entering Theoretical Torque Tube Rates .... 64  
   Excessive Mechanical Gain ..... 65  
   Determining the SG of an Unknown Fluid ... 65  
 Accuracy Considerations ..... 65  
   Effect of Proportional Band ..... 65  
   Density Variations in Interface Applications .. 65  
   Extreme Temperatures ..... 66  
   Temperature Compensation ..... 66  
**Section 5 Service Tools ..... 67**  
 Active Alerts ..... 67  
 Variables ..... 69  
 Maintenance ..... 71

**Section 6 Maintenance and  
 Troubleshooting ..... 73**  
 Diagnostic Messages ..... 73  
 Hardware Diagnostics ..... 74  
 Test Terminals ..... 76  
 Removing the Digital Level  
 Controller from the Sensor ..... 76  
   Removing the DLC3010 Digital Level Controller  
   from a 249 Sensor ..... 77  
     Standard Temperature Applications ..... 77  
     High Temperature Applications ..... 78  
 LCD Meter Assembly ..... 78  
   Removing the LCD Meter Assembly ..... 79  
   Replacing the LCD Meter Assembly ..... 79  
 Electronics Module ..... 80  
   Removing the Electronics Module ..... 80  
   Replacing the Electronics Module ..... 80  
 Terminal Box ..... 81  
   Removing the Terminal Box ..... 81  
   Replacing the Terminal Box ..... 81  
 Removing and Replacing the Inner Guide  
 and Access Handle Assembly ..... 82  
 Lever Assembly ..... 83  
   Removing the Lever Assembly ..... 83  
   Replacing the Lever Assembly ..... 84  
 Packing for Shipment ..... 85  
**Section 7 Parts ..... 87**  
 Parts Ordering ..... 87  
 Mounting Kits ..... 87  
 Repair Kits ..... 87  
 Parts List ..... 88  
   DLC3010 Digital Level Controllers ..... 88  
   Transducer Assembly ..... 89  
   Terminal Box Assembly ..... 90  
   Terminal Box Cover Assembly ..... 90  
   Mounting Parts ..... 91  
     249 Sensors with Heat Insulator ..... 91  
**Appendix A Principle of Operation ..... 95**  
 HART Communication ..... 95  
 Digital Level Controller Operation ..... 96  
**Appendix B Field Communicator**  
   **Menu Tree ..... 101**  
**Glossary ..... 107**

# Section 1 Introduction and Specifications

## Scope of Manual

This instruction manual includes specifications, installation, operating, and maintenance information for FIELDVUE DLC3010 digital level controllers.

This instruction manual supports the 475 or 375 Field Communicator with device description revision 3, used with DLC3010 instruments with firmware revision 8. You can obtain information about the process, instrument, or sensor using the Field Communicator. Contact your [Emerson sales office](#) or Local Business Partner to obtain the appropriate software

---

### Note

AMS Suite: Intelligent Device Manager can also be used to calibrate and configure the DLC3010, and to obtain information about the process, instrument, or sensor.

---

Do not install, operate, or maintain a DLC3010 digital level controller without being fully trained and qualified in valve, actuator, and accessory installation, operation, and maintenance. **To avoid personal injury or property damage, it is important to carefully read, understand, and follow all of the contents of this manual, including all safety cautions and warnings.** If you have any questions about these instructions, contact your Emerson sales office or Local Business Partner.

## Conventions Used in this Manual

This manual describes using the Field Communicator to calibrate and configure the digital level controller.

Procedures that require the use of the Field Communicator have the text path and the sequence of numeric keys required to display the desired Field Communicator menu.

For example, to access the *Full Calibration* menu:

Field Communicator	Configure > Calibration > Primary > Full Calibration (2-5-1-1)
--------------------	--

Menu selections are shown in italics, e.g., *Calibrate*. An overview of the Field Communicator menu structure is shown in Appendix B.

## Description

### DLC3010 Digital Level Controllers

DLC3010 digital level controllers (figure 1-1) are used with level sensors to measure liquid level, the level of interface between two liquids, or liquid specific gravity (density). Changes in level or specific gravity exert a buoyant force on a

displacer, which rotates the torque tube shaft. This rotary motion is applied to the digital level controller, transformed to an electrical signal and digitized. The digital signal is compensated and processed per user configuration requirements, and converted back to a 4-20 mA analog electrical signal. The resulting current output signal is sent to an indicating or final control element.

Figure 1-1. FIELDVUE DLC3010 Digital Level Controller



W7977-2

DLC3010 digital level controllers are communicating, microprocessor-based level, interface, or density sensing instruments. In addition to the normal function of providing a 4-20 milliamper current signal, DLC3010 digital level controllers, using the HART<sup>®</sup> communications protocol, give easy access to information critical to process operation. You can gain information from the process, the instrument, or the sensor using a Field Communicator with device descriptions (DDs) compatible with DLC3010 digital level controllers. The Field Communicator may be connected at the digital level controller or at a field junction box.

Using the Field Communicator, you can perform several operations with the DLC3010 digital level controller. You can interrogate, configure, calibrate, or test the digital level controller. Using the HART protocol, information from the field can be integrated into control systems or be received on a single loop basis.

DLC3010 digital level controllers are designed to directly replace standard pneumatic and electro-pneumatic level transmitters. DLC3010 digital level controllers mount on a wide variety of caged and cageless 249 level sensors. They mount on other manufacturers' displacer type level sensors through the use of mounting adaptors.

## 249 Caged Sensors (see table 1-6)

- 249, 249B, 249BF, 249C, 249K, and 249L sensors side-mount on the vessel with the displacer mounted inside a cage outside the vessel. (The 249BF caged sensor is available only in Europe, Middle East, and Africa.)

## 249 Cageless Sensors (see table 1-7)

- 249BP, 249CP, and 249P sensors top-mount on the vessel with the displacer hanging down into the vessel.
- 249VS sensor side-mounts on the vessel with the displacer hanging out into the vessel.
- 249W wafer-style sensor mounts on top of a vessel or on a customer-supplied cage.

## Specifications

Specifications for the DLC3010 digital level controller are shown in table 1-1. Specifications for the 249 sensor are shown in table 1-3. Specifications for the Field Communicator can be found in the [Product Manual](#) for the Field Communicator.

## Related Documents

Other documents containing information related to the DLC3010 digital level controller and 249 sensors include:

- Bulletin 11.2:DLC3010 - FIELDVUE DLC3010 Digital Level Controller ([D102727X012](#))
- FIELDVUE DLC3010 Digital Level Controller Quick Start Guide ([D103214X012](#))
- Using FIELDVUE Instruments with the Smart HART Loop Interface and Monitor (HIM) ([D103263X012](#))
- Audio Monitor for HART Communications ([D103265X012](#))
- Fisher 249 Caged Displacer Sensors Instruction Manual ([D200099X012](#))
- Fisher 249 Cageless Displacer Sensors Instruction Manual ([D200100X012](#))
- Fisher 249VS Cageless Displacer Sensor Instruction Manual ([D103288X012](#))
- Fisher 249W Cageless Wafer Style Level Sensor Instruction Manual ([D102803X012](#))
- Simulation of Process Conditions for Calibration of Fisher Level Controllers and Transmitters ([D103066X012](#))
- Bolt Torque Information ([D103220X012](#))
- Technical Monograph 7: The Dynamics of Level and Pressure Control
- Technical Monograph 18: Level-Trol Density Transmitter
- Technical Monograph 26: Guidelines for Selection of Liquid Level Control Equipment

These documents are available from your Emerson sale office, Local Business Partner, or at [Fisher.com](http://Fisher.com).

## Educational Services

For information on available courses for the DLC3010 digital level controller, as well as a variety of other products, contact:

Emerson Automation Solutions  
Educational Services, Registration  
Phone: +1-641-754-3771 or +1-800-338-8158  
e-mail: [education@emerson.com](mailto:education@emerson.com)  
[emerson.com/fishervalvetraining](http://emerson.com/fishervalvetraining)

Table 1-1. DLC3010 Digital Level Controller Specifications

**Available Configurations**

DLC3010 Digital Level Controller:  
Mounts on caged and cageless 249 sensors. See tables 1-6 and 1-7 and sensor description.

Function: Transmitter

Communications Protocol: HART

**Input Signal**

Level, Interface, or Density: Rotary motion of torque tube shaft proportional to changes in liquid level, interface level, or density that change the buoyancy of a displacer.

Process Temperature: Interface for 2- or 3-wire 100 ohm platinum RTD for sensing process temperature, or optional user-entered target temperature to permit compensating for changes in specific gravity

**Output Signal**

Analog: 4-20 milliamperes DC (■ direct action—increasing level, interface, or density increases output; or ■ reverse action—increasing level, interface, or density decreases output)

High saturation: 20.5 mA

Low saturation: 3.8 mA

High alarm: 22.5 mA

Low Alarm: 3.7 mA

Only one of the above high/low alarm definitions is available in a given configuration. NAMUR NE 43 compliant when high alarm level is selected.

Digital: HART 1200 Baud FSK (frequency shift keyed)

HART impedance requirements must be met to enable communication. Total shunt impedance across the master device connections (excluding the master and transmitter impedance) must be between 230 and 600 ohms. The transmitter HART receive impedance is defined as:

Rx: 42K ohms and

Cx: 14 nF

Note that in point-to-point configuration, analog and digital signalling are available. The instrument may be queried digitally for information, or placed in Burst mode to regularly transmit unsolicited process information digitally. In multi-drop mode, the output current is fixed at 4 mA, and only digital communication is available.

**Performance**

Performance Criteria	DLC3010 Digital Level Controller(1)	w/ NPS 3 249W, Using a 14-inch Displacer	w/ All Other 249 Sensors
Independent Linearity	± 0.25% of output span	± 0.8% of output span	± 0.5% of output span
Hysteresis	<0.2% of output span	---	---
Repeatability	± 0.1% of full scale output	± 0.5% of output span	± 0.3% of output span
Dead Band	<0.05% of input span	---	---
Hysteresis plus Deadband	---	<1.0% of output span	<1.0% of output span

NOTE: At full design span, reference conditions.  
1. To lever assembly rotation inputs.

At effective proportional band (PB)<100%, linearity, dead band, and repeatability are derated by the factor (100%/PB)

**Operating Influences**

Power Supply Effect: Output changes <±0.2% of full scale when supply varies between min. and max voltage specifications.

Transient Voltage Protection: The loop terminals are protected by a transient voltage suppressor. The specifications are as follows:

Pulse Waveform		Max V <sub>CL</sub> (Clamping Voltage) (V)	Max I <sub>pp</sub> (Pulse Peak @ Current) (A)
Rise Time (µs)	Decay to 50% (µs)		
10	1000	93.6	16
8	20	121	83

Note: µs = microsecond

Ambient Temperature: The combined temperature effect on zero and span without the 249 sensor is less than 0.03% of full scale per degree Kelvin over the operating range -40 to 80°C (-40 to 176°F)

Process Temperature: The torque rate is affected by the process temperature (see figure 1-2). The process density may also be affected by the process temperature.

Process Density: The sensitivity to error in knowledge of process density is proportional to the differential density of the calibration. If the differential specific gravity is 0.2, an error of 0.02 specific gravity units in knowledge of a process fluid density represents 10% of span.

-continued-

Table 1-1. DLC3010 Digital Level Controller Specifications (continued)

<p><b>Electromagnetic Compatibility</b></p> <p>Meets EN 61326-1:2013 and EN 61326-2-3:2006  Immunity—Industrial locations per Table 2 of EN 61326-1 and Table AA.2 of EN 61326-2-3.  Performance is shown in table 1-2 below.  Emissions—Class A  ISM equipment rating: Group 1, Class A</p> <p><b>Supply Requirements (See figure 2-10)</b></p> <p>12 to 30 volts DC <math>\overline{\text{---}}</math> ; 22.5 mA  Instrument has reverse polarity protection.  A minimum compliance voltage of 17.75 is required to guarantee HART communication.</p> <p><b>Compensation</b></p> <p>Transducer compensation: for ambient temperature.  Density parameter compensation: for process temperature (requires user-supplied tables).  Manual compensation: for torque tube rate at target process temperature is possible.</p> <p><b>Digital Monitors</b></p> <p>Linked to jumper-selected Hi (factory default) or Lo analog alarm signal:  <i>Torque tube position transducer:</i> Drive monitor and signal reasonableness monitor  <i>User-configurable alarms:</i> Hi-Hi and Lo-Lo Limit process alarms</p> <p><b>HART-readable only:</b>  <i>RTD signal reasonableness monitor:</i> When RTD installed  <i>Processor free-time monitor.</i>  <i>Writes-remaining in Non Volatile Memory monitor.</i>  <i>User-configurable alarms:</i> Hi and Lo limit process alarms, Hi and Lo limit process temperature alarms, and Hi and Lo limit electronics temperature alarms</p> <p><b>Diagnostics</b></p> <p><i>Output loop current diagnostic.</i>  <i>LCD meter diagnostic.</i>  <i>Spot specific gravity measurement in level mode:</i> used to update specific gravity parameter to improve process measurement  <i>Digital signal-tracing capability:</i> by review of “troubleshooting variables”, and  <i>Basic trending capability for PV, TV and SV.</i></p> <p><b>LCD Meter Indications</b></p> <p>LCD meter indicates analog output on a percent scale bar graph. The meter also can be configured to display:</p>	<p><i>Process variable in engineering units only.</i>  <i>Percent range only.</i>  <i>Percent range alternating with process variable or Process variable, alternating with process temperature (and degrees of pilot shaft rotation).</i></p> <p><b>Electrical Classification</b></p> <p>Pollution Degree IV, Overvoltage Category II per IEC 61010 clause 5.4.2 d</p> <p><b>Hazardous Area:</b></p> <p>CSA— Intrinsically Safe, Explosion-proof, Division 2, Dust Ignition-proof  FM— Intrinsically Safe, Explosion-proof, Non-incendive, Dust Ignition-proof  ATEX— Intrinsically Safe, Type n, Flameproof  IECEx— Intrinsically Safe, Type n, Flameproof</p> <p><b>Electrical Housing:</b></p> <p>CSA— Type 4X      ATEX— IP66  FM— NEMA 4X      IECEx— IP66</p> <p><b>Other Classifications/Certifications</b></p> <p>CUTR— Customs Union Technical Regulations (Russia, Kazakhstan, Belarus, and Armenia)  INMETRO— National Institute of Metrology, Standardization, and Industrial Quality (Brazil)  KGS— Korea Gas Safety Corporation (South Korea)  NEPSI— National Supervision and Inspection Centre for Explosion Protection and Safety of Instrumentation (China)  PESO CCOE— Petroleum and Explosives Safety Organisation - Chief Controller of Explosives (India)  TIIS— Technology Institution of Industrial Safety (Japan)  Contact your <a href="#">Emerson sales office</a> or Local Business Partner for classification/certification specific information</p> <p><b>Minimum Differential Specific Gravity</b></p> <p>With a nominal 4.4 degrees torque tube shaft rotation for a 0 to 100 percent change in liquid level (specific gravity=1), the digital level controller can be adjusted to provide full output for an input range of 5% of nominal input span. This equates to a minimum differential specific gravity of 0.05 with standard volume displacers.</p>
--	--

-continued-

Table 1-1. DLC3010 Digital Level Controller Specifications (continued)

<p><b>Minimum Differential Specific Gravity (continued)</b></p> <p>See 249 sensor specifications for standard displacer volumes and standard wall torque tubes. Standard volume for 249C and 249CP sensors is ~980 cm<sup>3</sup> (60 in<sup>3</sup>), most others have standard volume of ~1640 cm<sup>3</sup> (100 in<sup>3</sup>).</p> <p>Operating at 5% proportional band will degrade accuracy by a factor of 20. Using a thin wall torque tube, or doubling the displacer volume will each roughly double the effective proportional band. When proportional band of the system drops below 50%, changing displacer or torque tube should be considered if high accuracy is a requirement.</p> <p><b>Mounting Positions</b></p> <p>Digital level controllers can be mounted right- or left-of-displacer, as shown in figure 2-5.</p> <p>Instrument orientation is normally with the coupling access door at the bottom, to provide proper drainage of lever chamber and terminal compartment, and to limit gravitational effect on the lever assembly. If alternate drainage is provided by user, and a small performance loss is acceptable, the instrument could be mounted in 90 degree rotational increments around the pilot shaft axis. The LCD meter may be rotated in 90 degree increments to accommodate this.</p> <p><b>Construction Materials</b></p> <p><b>Case and Cover:</b> Low-copper aluminum alloy  <b>Internal:</b> Plated steel, aluminum, and stainless steel; encapsulated printed wiring boards; Neodymium Iron Boron Magnets</p>	<p><b>Electrical Connections</b></p> <p>Two 1/2-14 NPT internal conduit connections; one on bottom and one on back of terminal box. M20 adapters available.</p> <p><b>Options</b></p> <ul style="list-style-type: none"> <li>■ Heat insulator</li> <li>■ Mountings for Masoneilan™, Yamatake, and Foxboro™ -Eckhardt displacers available</li> <li>■ Level Signature Series Test (Performance Validation Report) available (EMA only) for instruments factory-mounted on 249 sensor</li> <li>■ Factory Calibration: available for instruments factory-mounted on 249 sensor, when application, process temperature and density(s) are supplied</li> <li>■ Device is compatible with user-specified remote indicator</li> </ul> <p><b>Operating Limits</b></p> <p><b>Process Temperature:</b> See table 1-4 and figure 2-7.  <b>Ambient Temperature and Humidity:</b> See below</p> <table border="1" style="width: 100%; border-collapse: collapse;"> <thead> <tr> <th>Conditions</th> <th>Normal Limits<sup>(1,2)</sup></th> <th>Transport and Storage Limits</th> <th>Nominal Reference</th> </tr> </thead> <tbody> <tr> <td>Ambient Temperature</td> <td>-40 to 80°C (-40 to 176°F)</td> <td>-40 to 85°C (-40 to 185°F)</td> <td>25°C (77°F)</td> </tr> <tr> <td>Ambient Relative Humidity</td> <td>0 to 95%, (non-condensing)</td> <td>0 to 95%, (non-condensing)</td> <td>40%</td> </tr> </tbody> </table> <p><b>Altitude Rating</b></p> <p>Up to 2000 meters (6562 feet)</p> <p><b>Weight</b></p> <p>Less than 2.7 Kg (6 lb)</p>	Conditions	Normal Limits <sup>(1,2)</sup>	Transport and Storage Limits	Nominal Reference	Ambient Temperature	-40 to 80°C (-40 to 176°F)	-40 to 85°C (-40 to 185°F)	25°C (77°F)	Ambient Relative Humidity	0 to 95%, (non-condensing)	0 to 95%, (non-condensing)	40%
Conditions	Normal Limits <sup>(1,2)</sup>	Transport and Storage Limits	Nominal Reference										
Ambient Temperature	-40 to 80°C (-40 to 176°F)	-40 to 85°C (-40 to 185°F)	25°C (77°F)										
Ambient Relative Humidity	0 to 95%, (non-condensing)	0 to 95%, (non-condensing)	40%										

NOTE: Specialized instrument terms are defined in ANSI/ISA Standard 51.1 - Process Instrument Terminology.  
 1. LCD meter may not be readable below -20°C (-4°F)  
 2. Contact your [Emerson sales office](#) or application engineer if temperatures exceeding these limits are required.

Table 1-2. EMC Summary Results—Immunity

Port	Phenomenon	Basic Standard	Test Level	Performance Criteria <sup>(1)(2)</sup>
Enclosure	Electrostatic discharge (ESD)	IEC 61000-4-2	4 kV contact 8 kV air	A
	Radiated EM field	IEC 61000-4-3	80 to 1000 MHz @ 10V/m with 1 kHz AM at 80% 1400 to 2000 MHz @ 3V/m with 1 kHz AM at 80% 2000 to 2700 MHz @ 1V/m with 1 kHz AM at 80%	A
	Rated power frequency magnetic field	IEC 61000-4-8	60 A/m at 50 Hz	A
I/O signal/control	Burst	IEC 61000-4-4	1 kV	A
	Surge	IEC 61000-4-5	1 kV (line to ground only, each)	B
	Conducted RF	IEC 61000-4-6	150 kHz to 80 MHz at 3 Vrms	A

Note: RTD wiring must be shorter than 3 meters (9.8 feet)  
 1. A = No degradation during testing. B = Temporary degradation during testing, but is self-recovering. Specification limit = +/- 1% of span.  
 2. HART communication was considered as "not relevant to the process" and is used primarily for configuration, calibration, and diagnostic purposes.



Figure 1-2. Theoretical Reversible Temperature Effect on Common Torque Tube Materials

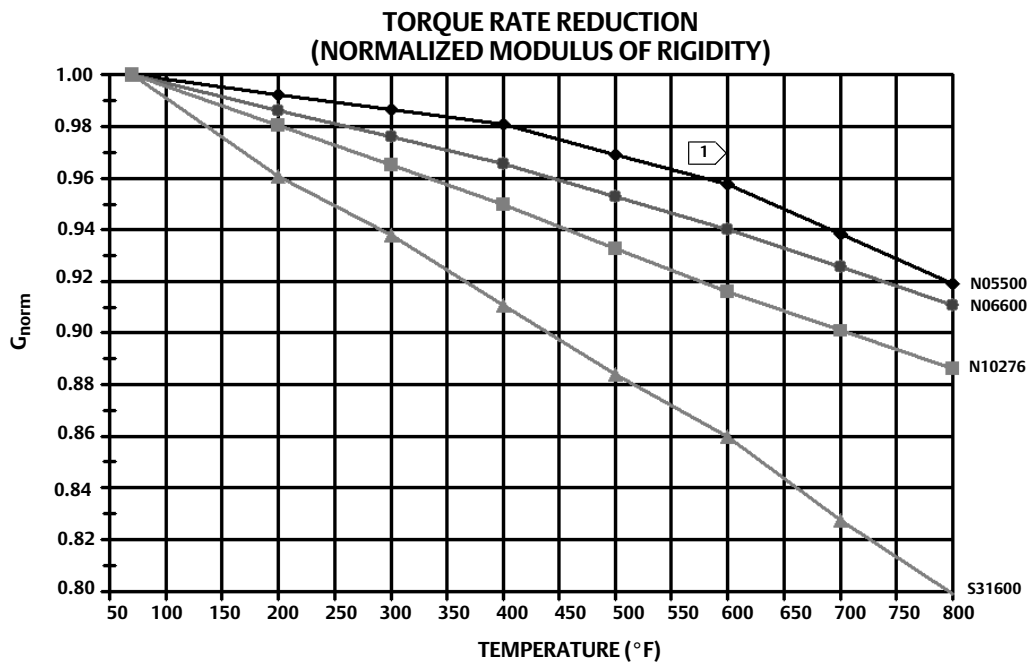
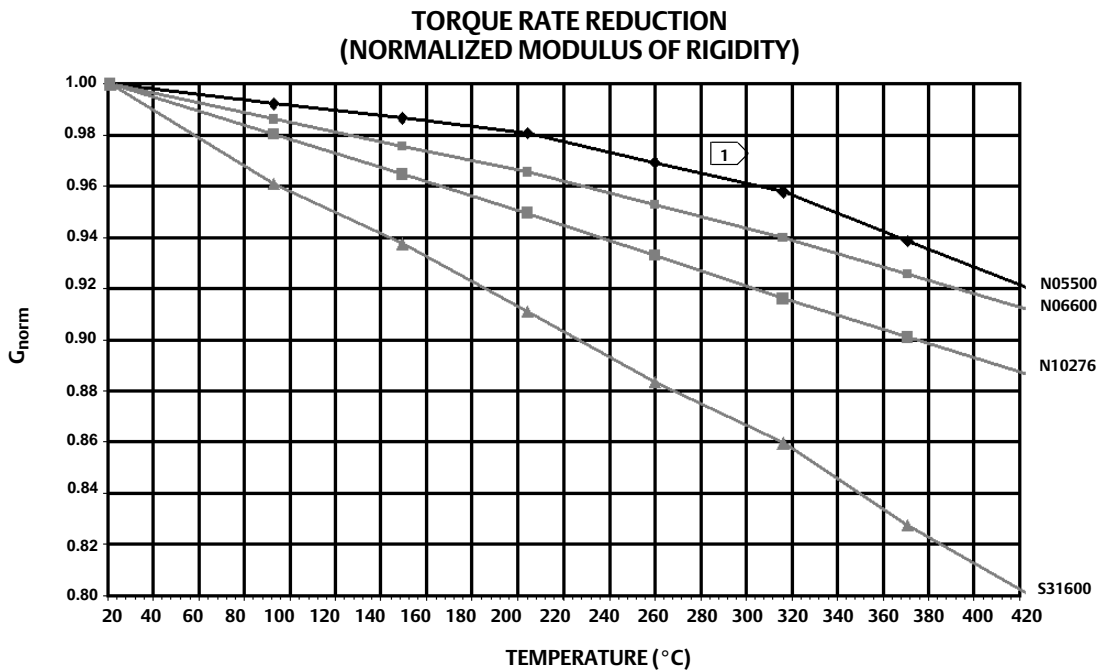

NOTE:  
 1) DUE TO THE PERMANENT DRIFT THAT OCCURS NEAR AND ABOVE 260°C (500°F), N05500 IS NOT RECOMMENDED FOR TEMPERATURES ABOVE 232°C (450°F).

Table 1-3. 249 Sensor Specifications

<p><b>Input Signal</b></p> <p>Liquid Level or Liquid-to-Liquid Interface Level: From 0 to 100 percent of displacer length                  Liquid Density: From 0 to 100 percent of displacement force change obtained with given displacer volume—standard volumes are ■ 980 cm<sup>3</sup> (60 inches<sup>3</sup>) for 249C and 249CP sensors or ■ 1640 cm<sup>3</sup> (100 inches<sup>3</sup>) for most other sensors; other volumes available depending upon sensor construction</p> <p><b>Sensor Displacer Lengths</b></p> <p>See tables 1-6 and 1-7 footnotes</p> <p><b>Sensor Working Pressures</b></p> <p>Consistent with applicable ANSI pressure/temperature ratings for the specific sensor constructions shown in tables 1-6 and 1-7</p> <p><b>Caged Sensor Connection Styles</b></p> <p>Cages can be furnished in a variety of end connection styles to facilitate mounting on vessels; the</p>	<p>equalizing connection styles are numbered and are shown in figure 1-3.</p> <p><b>Mounting Positions</b></p> <p>Most level sensors with cage displacers have a rotatable head. The head may be rotated through 360 degrees to any of eight different positions, as shown in figure 2-5.</p> <p><b>Construction Materials</b></p> <p>See tables 1-5, 1-6, and 1-7</p> <p><b>Operative Ambient Temperature</b></p> <p>See table 1-4                  For ambient temperature ranges, guidelines, and use of optional heat insulator, see figure 2-7.</p> <p><b>Options</b></p> <p>■ Heat insulator ■ Gauge glass for pressures to 29 bar at 232°C (420 psig at 450°F), and ■ Reflex gauges for high temperature and pressure applications</p>
--	---

Table 1-4. Allowable Process Temperatures for Common 249 Sensor Pressure Boundary Materials

MATERIAL	PROCESS TEMPERATURE	
	Min.	Max.
Cast Iron	-29°C (-20°F)	232°C (450°F)
Steel	-29°C (-20°F)	427°C (800°F)
Stainless Steel	-198°C (-325°F)	427°C (800°F)
N04400	-198°C (-325°F)	427°C (800°F)
Graphite Laminate/SST Gaskets	-198°C (-325°F)	427°C (800°F)
N04400/PTFE Gaskets	-73°C (-100°F)	204°C (400°F)

Table 1-5. Displacer and Torque Tube Materials

Part	Standard Material	Other Materials
Displacer	304 Stainless Steel	316 Stainless Steel, N10276, N04400, Plastic, and Special Alloys
Displacer Stem Driver Bearing, Displacer Rod and Driver	316 Stainless Steel	N10276, N04400, other Austenitic Stainless Steels, and Special Alloys
Torque Tube	N05500 <sup>(1)</sup>	316 Stainless Steel, N06600, N10276

1. N05500 is not recommended for spring applications above 232°C (450°F). Contact your [Emerson sales office](#) or application engineer if temperatures exceeding this limit are required.

Table 1-6. Caged Displacer Sensors<sup>(1)</sup>

TORQUE TUBE ORIENTATION	SENSOR	STANDARD CAGE, HEAD, AND TORQUE TUBE ARM MATERIAL	EQUALIZING CONNECTION		PRESSURE RATING <sup>(2)</sup>	
			Style	Size (NPS)		
Torque tube arm rotatable with respect to equalizing connections	249 <sup>(3)</sup>	Cast iron	Screwed	1-1/2 or 2	CL125 or CL250	
			Flanged	2		
	249B, 249BF <sup>(4)</sup>	Steel	Screwed or optional socket weld		1-1/2 or 2	CL600
			Raised face or optional ring-type joint flanged	1-1/2	CL150, CL300, or CL600	
				2	CL150, CL300, or CL600	
	249C <sup>(3)</sup>	316 stainless steel	Screwed		1-1/2 or 2	CL600
			Raised face flanged	1-1/2	CL150, CL300, or CL600	
				2	CL150, CL300, or CL600	
249K	Steel	Raised face or optional ring-type joint flanged		1-1/2 or 2	CL900 or CL1500	
249L	Steel	Ring-type joint flanged		2 <sup>(5)</sup>	CL2500	

1. Standard displacer lengths for all styles (except 249) are 14, 32, 48, 60, 72, 84, 96, 108 and 120 inches. The 249 uses a displacer with a length of either 14 or 32 inches.  
 2. EN flange connections available in EMA (Europe, Middle East and Africa).  
 3. Not available in EMA.  
 4. The 249BF available in EMA only. Also available in EN size DN 40 with PN 10 to PN 100 flanges and size DN 50 with PN 10 to PN 63 flanges.  
 5. Top connection is NPS 1 ring-type joint flanged for connection styles F1 and F2.

Table 1-7. Cageless Displacer Sensors<sup>(1)</sup>

Mounting	Sensor	Standard Head <sup>(2)</sup> , Wafer Body <sup>(6)</sup> and Torque Tube Arm Material	Flange Connection (Size)	Pressure Rating <sup>(3)</sup>
Mounts on top of vessel	249BP <sup>(4)</sup>	Steel	NPS 4 raised face or optional ring-type joint	CL150, CL300, or CL600
			NPS 6 or 8 raised face	CL150 or CL300
	249CP	316 Stainless Steel	NPS 3 raised face	CL150, CL300, or CL600
	249P <sup>(5)</sup>	Steel or stainless steel	NPS 4 raised face or optional ring-type joint	CL900 or 1CL500 (EN PN 10 to DIN PN 250)
			NPS 6 or 8 raised face	CL150, CL300, CL600, CL900, CL1500, or CL2500
Mounts on side of vessel	249VS	WCC (steel) LCC (steel), or CF8M (316 stainless steel)	For NPS 4 raised face or flat face	CL125, CL150, CL250, CL300, CL600, CL900, or CL1500 (EN PN 10 to DIN PN 160)
		WCC, LCC, or CF8M	For NPS 4 butt-weld end, XXZ	CL2500
Mounts on top of vessel or on customer supplied cage	249W	WCC or CF8M	For NPS 3 raised face	CL150, CL300, or CL600
		LCC or CF8M	For NPS 4 raised face	CL150, CL300, or CL600

1. Standard displacer lengths are 14, 32, 48, 60, 72, 84, 96, 108, and 120 inches.  
 2. Not used with side-mounted sensors.  
 3. EN flange connections available in EMA (Europe, Middle East and Africa).  
 4. Not available in EMA.  
 5. 249P available in EMA only.  
 6. Wafer Body only applicable to the 249W.

Figure 1-3. Style Number of Equalizing Connections

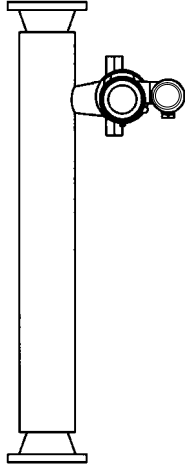

STYLE 1  
TOP AND BOTTOM CONNECTIONS,  
SCREWED (S-1) OR FLANGED (F-1)

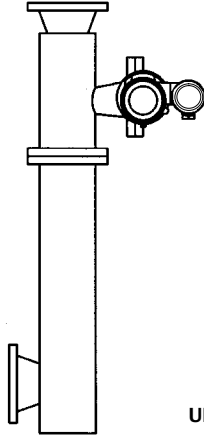

STYLE 2  
TOP AND LOWER SIDE CONNECTIONS,  
SCREWED (S-2) OR FLANGED (F-2)

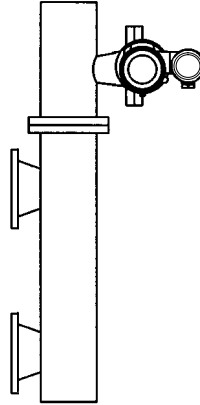

STYLE 3  
UPPER AND LOWER SIDE CONNECTIONS,  
SCREWED (S-3) OR FLANGED (F-3)

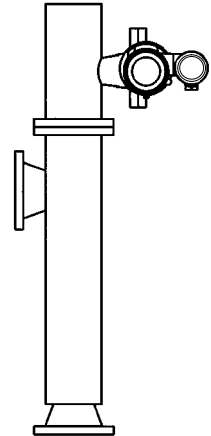

STYLE 4  
UPPER SIDE AND BOTTOM CONNECTIONS,  
SCREWED (S-4) OR FLANGED (F-4)

## Section 2 Installation

This section contains digital level controller installation information including an installation flowchart (figure 2-1), mounting and electrical installation information, and a discussion of failure mode jumpers.

### Configuration: On the Bench or in the Loop

Configure the digital level controller before or after installation. It may be useful to configure the instrument on the bench before installation to ensure proper operation, and to familiarize yourself with its functionality.

### Protecting the Coupling and Flexures

#### CAUTION

**Damage to flexures and other parts can cause measurement errors. Observe the following steps before moving the sensor and controller.**

---

#### Lever Lock

The lever lock is built in to the coupling access handle. When the handle is open, it positions the lever in the neutral travel position for coupling. In some cases, this function is used to protect the lever assembly from violent motion during shipment.

A DLC3010 controller will have one of the following mechanical configurations when received:

1. A fully assembled and coupled caged-displacer system shipped with the displacer or driver rod blocked within the operating range by mechanical means. In this case, the access handle (figure 2-4) will be in the unlocked position. Remove the displacer-blocking hardware before calibration. (See the appropriate sensor instruction manual). The coupling should be intact.

#### CAUTION

**When shipping an instrument mounted on a sensor, if the lever assembly is coupled to the linkage, and the linkage is constrained by the displacer blocks, use of the lever lock may result in damage to bellows joints or flexure.**

---

2. If the displacer cannot be blocked because of cage configuration or other concerns, the transmitter is uncoupled from the torque tube by loosening the coupling nut, and the access handle will be in the locked position. Before placing such a configuration into service, perform the Coupling procedure found on page 38.
3. For a cageless system where the displacer is not connected to the torque tube during shipping, the torque tube itself stabilizes the coupled lever position by resting against a physical stop in the sensor. The access handle will be in the unlocked position. Mount the sensor and hang the displacer. The coupling should be intact.

Figure 2-1. Installation Flowchart

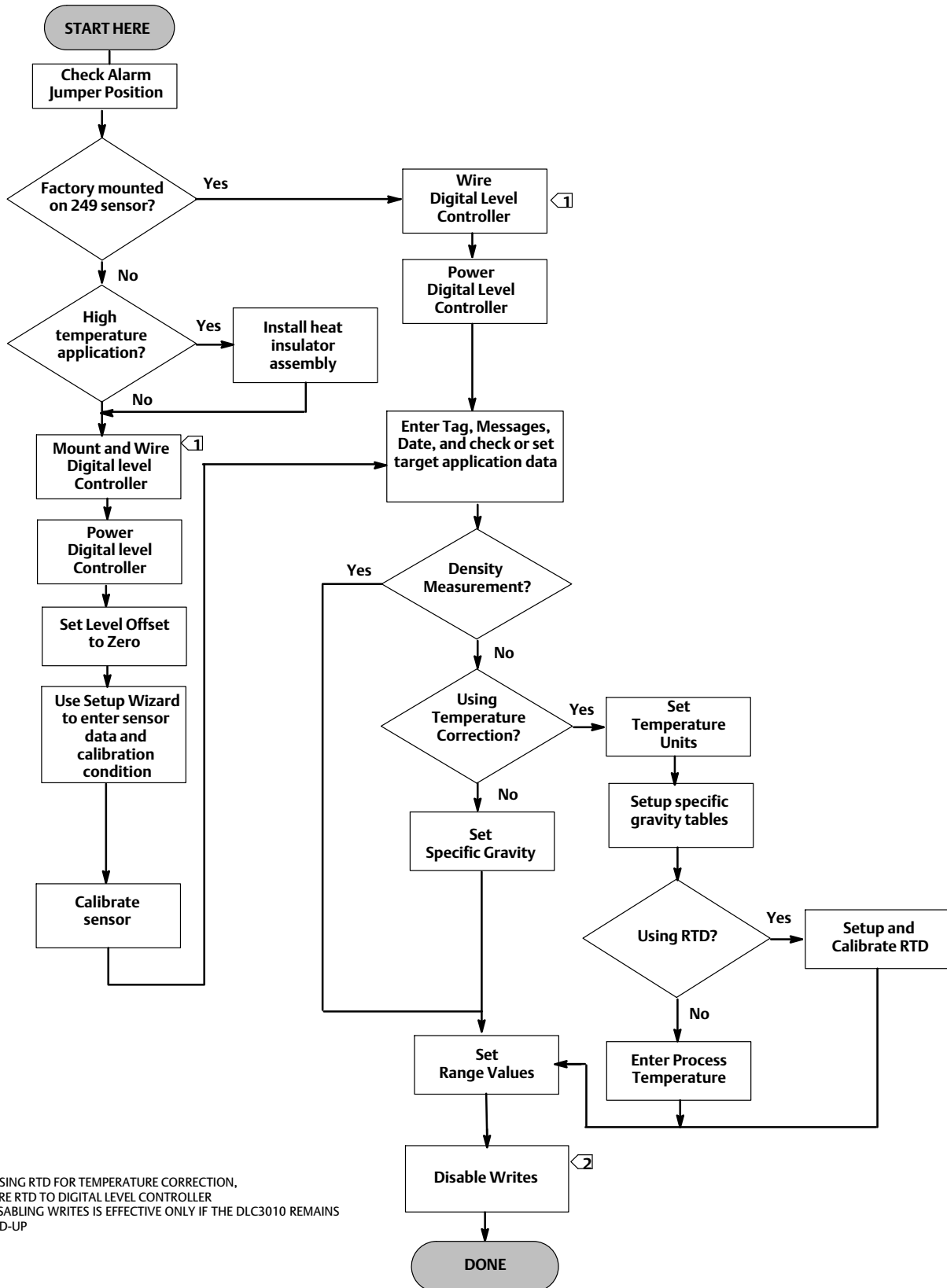

NOTE:  
 1 IF USING RTD FOR TEMPERATURE CORRECTION, ALSO WIRE RTD TO DIGITAL LEVEL CONTROLLER  
 2 DISABLING WRITES IS EFFECTIVE ONLY IF THE DLC3010 REMAINS POWERED-UP

4. If the controller was shipped alone, the access handle will be in the locked position. All Mounting, Coupling and Calibration procedures must be performed.

The access handle includes a retaining set screw, as shown in figures 2-4 and 2-6. The screw is driven in to contact the spring plate in the handle assembly before shipping. It secures the handle in the desired position during shipping and operation. To set the access handle in the open or closed position, this set screw must be backed out so that its top is flush with the handle surface.

## Mounting

### **⚠ WARNING**

To avoid personal injury, always wear protective gloves, clothing, and eyewear when performing any installation operations.

Personal injury or property damage due to sudden release of pressure, contact with hazardous fluid, fire, or explosion can be caused by puncturing, heating, or repairing a displacer that is retaining process pressure or fluid. This danger may not be readily apparent when disassembling the sensor or removing the displacer. Before disassembling the sensor or removing the displacer, observe the appropriate warnings provided in the sensor instruction manual.

Check with your process or safety engineer for any additional measures that must be taken to protect against process media.

---

## Hazardous Area Classifications and Special Instructions for “Safe Use” and Installations in Hazardous Locations

Refer to the DLC3010 Quick Start Guide ([D103214X012](#)) that ships with the instrument for Hazardous Area Classifications and Special Instructions for “Safe Use” and Installations in Hazardous Locations. If a copy of this quick start guide is needed contact your Emerson sales office or Local Business Partner, or visit our website at [Fisher.com](http://Fisher.com).

## Mounting the 249 Sensor

The 249 sensor is mounted using one of two methods, depending on the specific type of sensor. If the sensor has a caged displacer, it typically mounts on the side of the vessel as shown in figure 2-2. If the sensor has a cageless displacer, the sensor mounts on the side or top of the vessel as shown in figure 2-3.

The DLC3010 digital level controller is typically shipped attached to the sensor. If ordered separately, it may be convenient to mount the digital level controller to the sensor and perform the initial setup and calibration before installing the sensor on the vessel.

---

### **Note**

Caged sensors have a rod and block installed on each end of the displacer to protect the displacer in shipping. Remove these parts before installing the sensor to allow the displacer to function properly.

---

Figure 2-2. Typical Caged Sensor Mounting

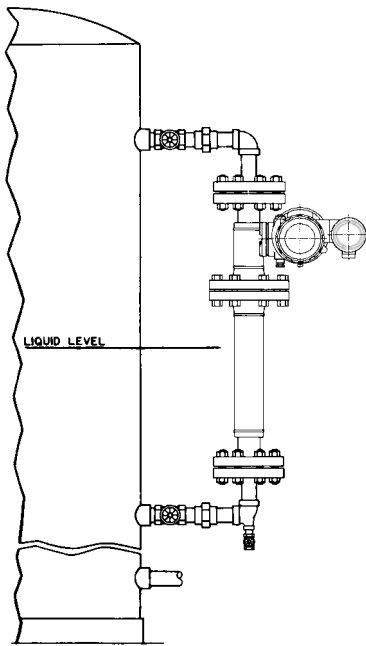
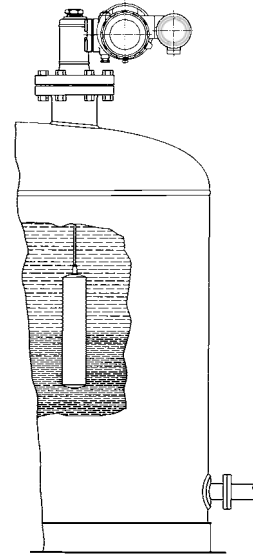

Figure 2-3. Typical Cageless Sensor Mounting



## Digital Level Controller Orientation

Mount the digital level controller with the torque tube shaft clamp access hole (see figure 2-4) pointing downward to allow accumulated moisture drainage.

Figure 2-4. Sensor Connection Compartment (Adapter Ring Removed for Clarity)

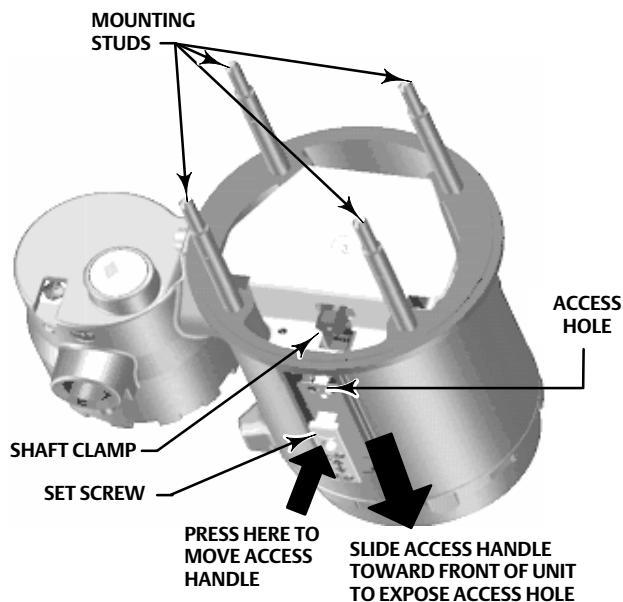



**Note**

If alternate drainage is provided by the user, and a small performance loss is acceptable, the instrument could be mounted in 90 degree rotational increments around the pilot shaft axis. The LCD meter may be rotated in 90 degree increments to accommodate this.

The digital level controller and torque tube arm are attached to the sensor either to the left or right of the displacer, as shown in figure 2-5. This can be changed in the field on the 249 sensors (refer to the appropriate sensor instruction manual). Changing the mounting also changes the effective action, because the torque tube rotation for increasing level, (looking at the protruding shaft), is clockwise when the unit is mounted to the right of the displacer and counter-clockwise when the unit is mounted to the left of the displacer.

All caged 249 sensors have a rotatable head. That is, the digital level controller can be positioned at any of eight alternate positions around the cage as indicated by the position numbers 1 through 8 in figure 2-5. To rotate the head, remove the head flange bolts and nuts and position the head as desired.

**Figure 2-5. Typical Mounting Positions for the FIELDVUE DLC3010 Digital Level Controller on Fisher 249 Sensor**

SENSOR	LEFT-OF-DISPLACER	RIGHT-OF-DISPLACER
CAGED		
CAGELESS		
<p>1 Not available for NPS 2 CL300 and 600 249C.</p>		

## Mounting the Digital Level Controller on a 249 Sensor

Refer to figure 2-4 unless otherwise indicated.

1. If the set-screw in the access handle (figure 2-6) is driven against the spring plate, back it out until the head is flush with the outer surface of the handle, using a 2 mm hex key. Slide the access handle to the locked position to expose the access hole. Press on the back of the handle as shown in figure 2-4 then slide the handle toward the front of the unit. Be sure the locking handle drops into the detent.

Figure 2-6. Close-up of Set-Screw

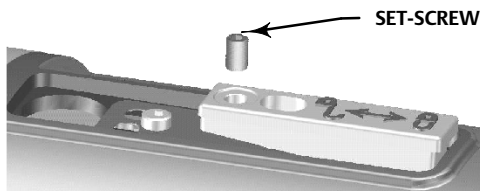

2. Using a 10 mm deep well socket inserted through the access hole, loosen the shaft clamp (figure 2-4). This clamp will be re-tightened in the Coupling portion of the Initial Setup section.
3. Remove the hex nuts from the mounting studs. Do not remove the adapter ring.

### CAUTION

Measurement errors can occur if the torque tube assembly is bent or misaligned during installation.

4. Position the digital level controller so the access hole is on the bottom of the instrument.
5. Carefully slide the mounting studs into the sensor mounting holes until the digital level controller is snug against the sensor.
6. Reinstall the hex nuts on the mounting studs and tighten the hex nuts to 10 N•m (88.5 lbf•in).

## Mounting the Digital Level Controller for High Temperature Applications

Refer to figure 2-8 for parts identification except where otherwise indicated.

The digital level controller requires an insulator assembly when temperatures exceed the limits shown in figure 2-7.

A torque tube shaft extension is required for a 249 sensor when using an insulator assembly.

### CAUTION

Measurement errors can occur if the torque tube assembly is bent or misaligned during installation.

Figure 2-7. Guidelines for Use of Optional Heat Insulator Assembly

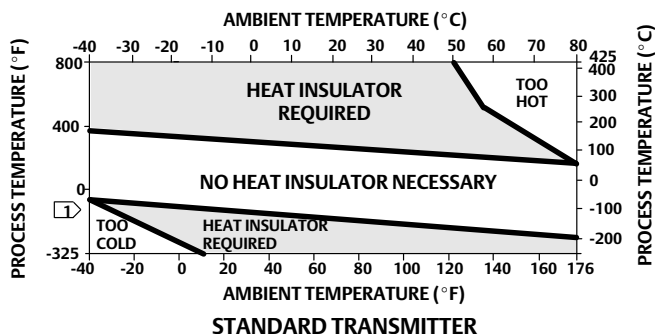

NOTES:  
 1. FOR PROCESS TEMPERATURES BELOW -29°C (-20°F) AND ABOVE 204°C (400°F) SENSOR MATERIALS MUST BE APPROPRIATE FOR THE PROCESS; SEE TABLE 1-4.  
 2. IF AMBIENT DEW POINT IS ABOVE PROCESS TEMPERATURE, ICE FORMATION MIGHT CAUSE INSTRUMENT MALFUNCTION AND REDUCE INSULATOR EFFECTIVENESS.

39A4070-B  
 A5494-1

Figure 2-8. Digital Level Controller Mounting on Sensor in High Temperature Applications

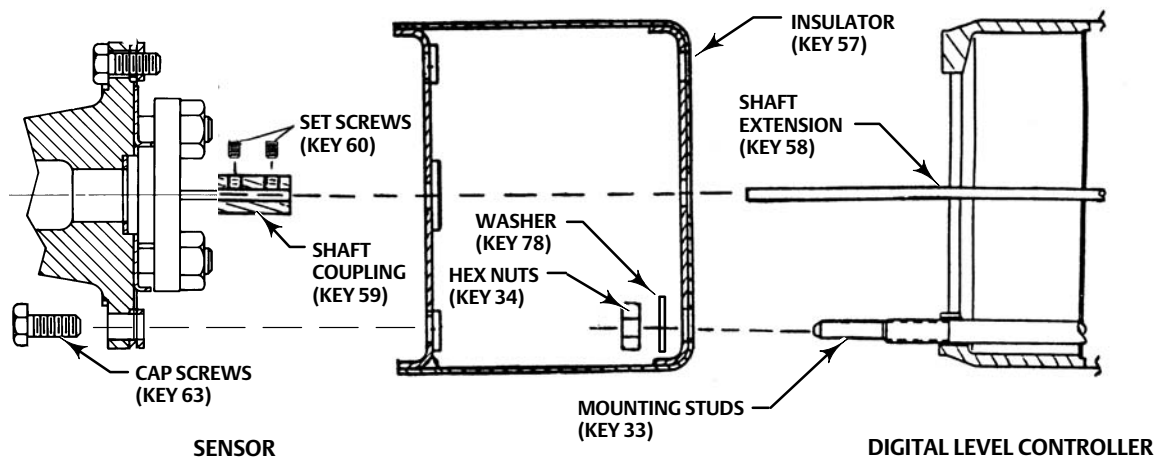

MN28800  
 20A7423-C  
 B2707

1. For mounting a digital level controller on a 249 sensor, secure the shaft extension to the sensor torque tube shaft via the shaft coupling and set screws, with the coupling centered as shown in figure 2-8.
2. Slide the access handle to the locked position to expose the access hole. Press on the back of the handle as shown in figure 2-4 then slide the handle toward the front of the unit. Be sure the locking handle drops into the detent.
3. Remove the hex nuts from the mounting studs.
4. Position the insulator on the digital level controller, sliding the insulator straight over the mounting studs.
5. Install 4 washers (key 78) over the studs. Install the four hex nuts and tighten.
6. Carefully slide the digital level controller with the attached insulator over the shaft coupling so that the access hole is on the bottom of the digital level controller.
7. Secure the digital level controller and insulator to the torque tube arm with four cap screws.
8. Tighten the cap screws to 10 N•m (88.5 lbf•in).

## Electrical Connections

### ⚠ WARNING

Select wiring and/or cable glands that are rated for the environment of use (such as hazardous area, ingress protection and temperature). Failure to use properly rated wiring and/or cable glands can result in personal injury or property damage from fire or explosion.

Wiring connections must be in accordance with local, regional, and national codes for any given hazardous area approval. Failure to follow the local, regional, and national codes could result in personal injury or property damage from fire or explosion.

Proper electrical installation is necessary to prevent errors due to electrical noise. A resistance between 230 and 600 ohms must be present in the loop for communication with a Field Communicator. Refer to figure 2-9 for current loop connections.

Figure 2-9. Connecting a Field Communicator to the Digital Level Controller Loop

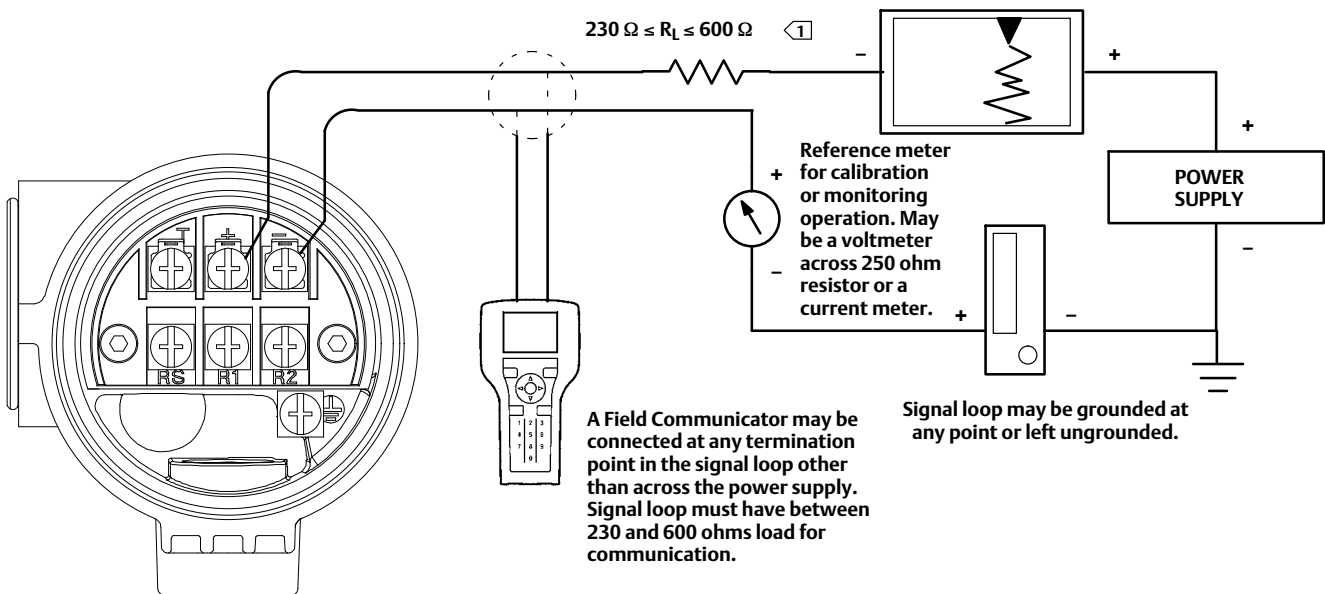

NOTE:  
① THIS REPRESENTS THE TOTAL SERIES LOOP RESISTANCE.

E0363

## Power Supply

To communicate with the digital level controller, you need a 17.75 volt DC minimum power supply. The power supplied to the transmitter terminals is determined by the available supply voltage minus the product of the total loop resistance and the loop current. The available supply voltage should not drop below the lift-off voltage. (The lift-off voltage is the minimum “available supply voltage” required for a given total loop resistance). Refer to figure 2-10 to

determine the required lift-off voltage. If you know your total loop resistance you can determine the lift-off voltage. If you know the available supply voltage, you can determine the maximum allowable loop resistance.

Figure 2-10. Power Supply Requirements and Load Resistance

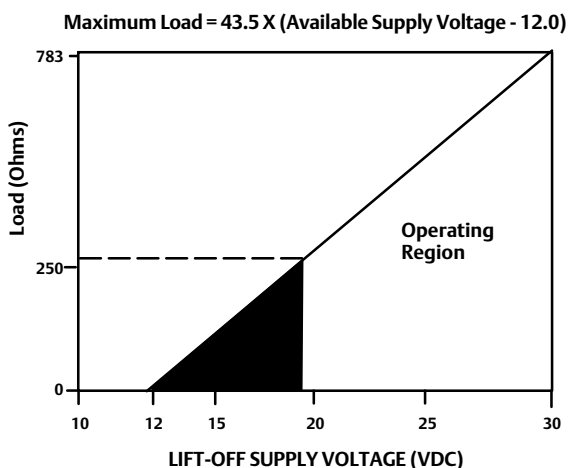

If the power supply voltage drops below the lift-off voltage while the transmitter is being configured, the transmitter may output incorrect information.

The DC power supply should provide power with less than 2% ripple. The total resistance load is the sum of the resistance of the signal leads and the load resistance of any controller, indicator, or related pieces of equipment in the loop. Note that the resistance of intrinsic safety barriers, if used, must be included.

## Field Wiring

### Note

For intrinsically safe applications, refer to the instructions supplied by the barrier manufacturer.

### **⚠ WARNING**

**To avoid personal injury or property damage caused by fire or explosion, remove power to the instrument before removing the digital level controller cover in an area which contains a potentially explosive atmosphere or has been classified as hazardous.**

All power to the digital level controller is supplied over the signal wiring. Signal wiring need not be shielded, but use twisted pairs for best results. Do not run unshielded signal wiring in conduit or open trays with power wiring, or near heavy electrical equipment. If the digital controller is in an explosive atmosphere, do not remove the digital level controller covers when the circuit is alive, unless in an intrinsically safe installation. Avoid contact with leads and terminals. To power the digital level controller, connect the positive power lead to the + terminal and the negative power lead to the - terminal as shown in figure 2-11.

Figure 2-11. Digital Level Controller Terminal Box

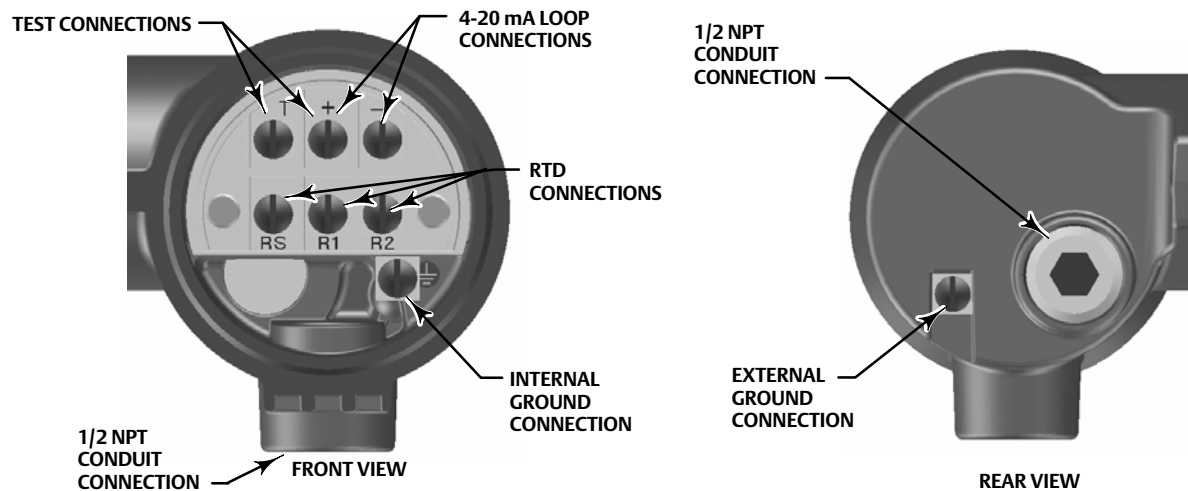

W8041

## CAUTION

Do not apply loop power across the T and + terminals. This can destroy the 1 Ohm sense resistor in the terminal box. Do not apply loop power across the Rs and – terminals. This can destroy the 50 Ohm sense resistor in the electronics module.

When wiring to screw terminals, the use of crimped lugs is recommended. Tighten the terminal screws to ensure that good contact is made. No additional power wiring is required. All digital level controller covers must be fully engaged to meet explosion proof requirements. For ATEX approved units, the terminal box cover set screw must engage one of the recesses in the terminal box beneath the terminal box cover.

## Grounding

### ⚠ WARNING

Personal injury or property damage can result from fire or explosion caused by the discharge of static electricity when flammable or hazardous gases are present. Connect a 14 AWG (2.1 mm<sup>2</sup>) ground strap between the digital level controller and earth ground when flammable or hazardous gases are present. Refer to national and local codes and standards for grounding requirements.

The digital level controller will operate with the current signal loop either floating or grounded. However, the extra noise in floating systems affects many types of readout devices. If the signal appears noisy or erratic, grounding the current signal loop at a single point may solve the problem. The best place to ground the loop is at the negative terminal of the power supply. As an alternative, ground either side of the readout device. Do not ground the current signal loop at more than one point.

### Shielded Wire

Recommended grounding techniques for shielded wire usually call for a single grounding point for the shield. You can either connect the shield at the power supply or to the grounding terminals, either internal or external, at the instrument terminal box shown in figure 2-11.

## Power/Current Loop Connections

Use ordinary copper wire of sufficient size to ensure that the voltage across the digital level controller terminals does not go below 12.0 volts DC. Connect the current signal leads as shown in figure 2-9. After making connections, recheck the polarity and correctness of connections, then turn the power on.

## RTD Connections

An RTD that senses process temperatures may be connected to the digital level controller. This permits the instrument to automatically make specific gravity corrections for temperature changes. For best results, locate the RTD as close to the displacer as practical. For optimum EMC performance, use shielded wire no longer than 3 meters (9.8 feet) to connect the RTD. Connect only one end of the shield. Connect the shield to either the internal ground connection in the instrument terminal box or to the RTD thermowell. Wire the RTD to the digital level controller as follows (refer to figure 2-11):

### Two-Wire RTD Connections

1. Connect a jumper wire between the RS and R1 terminals in the terminal box.
2. Connect the RTD to the R1 and R2 terminals.

---

#### Note

During Manual Setup, you must specify the connecting wire resistance for a 2-wire RTD. 250 feet of 16 AWG wire has a resistance of 1 ohm.

---

### Three-Wire RTD Connections

1. Connect the 2 wires which are connected to the same end of the RTD to the RS and R1 terminals in the terminal box. Usually these wires are the same color.
2. Connect the third wire to terminal R2. (The resistance measured between this wire and either wire connected to terminal RS or R1 should read an equivalent resistance for the existing ambient temperature. Refer to the RTD manufacturer's temperature to resistance conversion table.) Usually this wire is a different color from the wires connected to the RS and R1 terminals.

## Communication Connections

### **⚠ WARNING**

**Personal injury or property damage caused by fire or explosion may occur if this connection is attempted in an area which contains a potentially explosive atmosphere or has been classified as hazardous. Confirm that area classification and atmosphere conditions permit the safe removal of the terminal box cap before proceeding.**

---

The Field Communicator interfaces with digital level controller from any wiring termination point in the 4–20 mA loop (except across the power supply). If you choose to connect the HART communicating device directly to the instrument, attach the device to the loop + and - terminals inside the terminal box to provide local communications with the instrument.

## Test Connections

### **⚠ WARNING**

**Personal injury or property damage caused by fire or explosion may occur if the following procedure is attempted in an area which contains a potentially explosive atmosphere or has been classified as hazardous. Confirm that area classification and atmosphere conditions permit the safe removal of the terminal box cap before proceeding.**

Test connections inside the terminal box can be used to measure loop current across an internal 1 ohm resistor.

1. Remove the terminal box cap.
2. Adjust the test meter to measure a range of 0.001 to 0.1 volts.
3. Connect the positive lead of the test meter to the + connection and the negative lead to the T connection inside the terminal box.
4. Measure Loop current as:

Voltage (on test meter)  $\times$  1000 = milliamps

example:

Test meter Voltage  $\times$  1000 = Loop Milliamps

0.004  $\times$  1000 = 4.0 milliamperes

0.020  $\times$  1000 = 20.0 milliamperes

5. Remove test leads and replace the terminal box cover.

## Multichannel Installations

You can connect several instruments to a single master power supply as shown in figure 2-12. In this case, the system may be grounded only at the negative power supply terminal. In multichannel installations where several instruments depend on one power supply, and the loss of all instruments would cause operational problems, consider an uninterruptible power supply or a back-up battery. The diodes shown in figure 2-12 prevent unwanted charging or discharging of the back-up battery. If several loops are connected in parallel, make sure the net loop impedance does not reach levels that would prevent communication.



Figure 2-12. Multichannel Installations

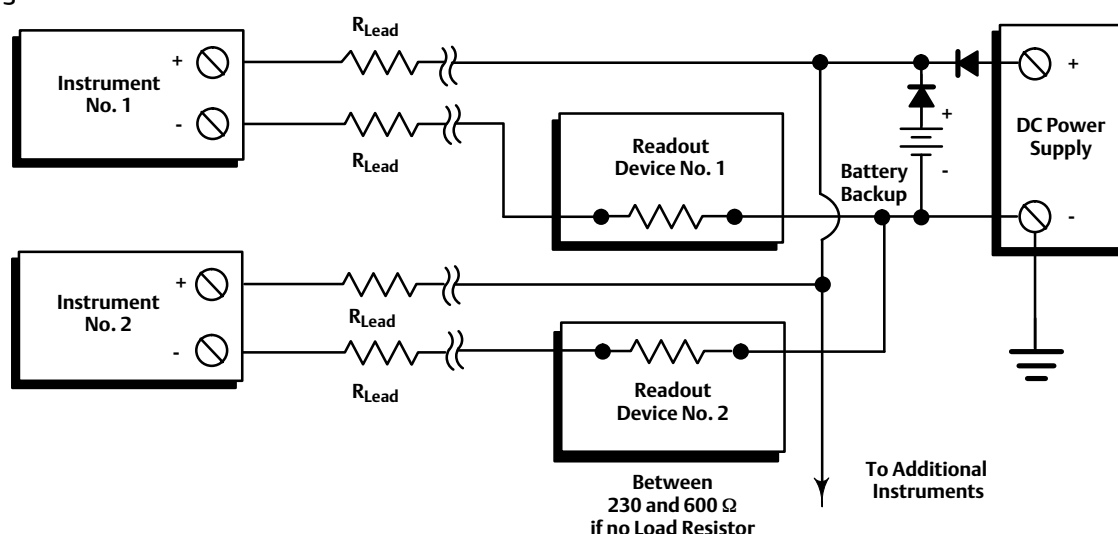

E0364

Note that to provide a 4-20 mA analog output signal, the DLC3010 must use HART polling address 0. Therefore, if a multichannel installation is used with all transmitters in 4-20 mA output mode, some means must be provided to isolate an individual transmitter for configuration or diagnostic purposes. A multichannel installation is most useful if the instruments are also in multi-drop mode and all signaling is done by digital polling.

## Alarm Jumper

Each digital level controller continuously monitors its own performance during normal operation. This automatic diagnostic routine is a timed series of checks repeated continuously. If diagnostics detect a failure in the electronics, the instrument drives its output to either below 3.70 mA or above 22.5 mA, depending on the position (HI/LO) of the alarm jumper.

An alarm condition occurs when the digital level controller self-diagnostics detect an error that would render the process variable measurement inaccurate, incorrect, or undefined, or a user defined threshold is violated. At this point the analog output of the unit is driven to a defined level either above or below the nominal 4-20 mA range, based on the position of the alarm jumper.

On encapsulated electronics 14B5483X042 and earlier, if the jumper is missing, the alarm is indeterminate, but usually behaves as a FAIL LOW selection. On encapsulated electronics 14B5483X052 and later, the behavior will default to FAIL HIGH when the jumper is missing.

### Alarm Jumper Locations

#### Without a meter installed

The alarm jumper is located on the front side of the electronics module on the electronics side of the digital level controller housing, and is labeled FAIL MODE.

#### With a meter installed

The alarm jumper is located on the LCD faceplate on the electronics module side of the digital level controller housing, and is labeled FAIL MODE.

## Changing Jumper Position

### **⚠ WARNING**

**Personal injury or property damage caused by fire or explosion may occur if the following procedure is attempted in an area which contains a potentially explosive atmosphere or has been classified as hazardous. Confirm that area classification and atmosphere conditions permit the safe removal of the instrument cover before proceeding.**

Use the following procedure to change the position of the alarm jumper:

1. If the digital level controller is installed, set the loop to manual.
2. Remove the housing cover on the electronics side. Do not remove the cover in explosive atmospheres when the circuit is alive.
3. Set the jumper to the desired position.
4. Replace the cover. All covers must be fully engaged to meet explosion proof requirements. For ATEX approved units, the set screw on the transducer housing must engage one of the recesses in the cover.

## Loop Test

Field Communicator	Service Tools > Maintenance > Tests > Loop Test (3-3-1-1) or (3-3-1-2) if LCD Configuration is installed
--------------------	--

Loop test can be used to verify the controller output, the integrity of the loop, and the operations of any recorders or similar devices installed in the loop. To initiate a loop test, perform the following procedure:

1. Connect a reference meter to the controller. To do so, either connect the meter to the test connections inside the terminal box (see the Test Connections procedure) or connect the meter in the loop as shown in figure 2-9.
2. Access *Loop Test*.
3. Select *OK* after you set the control loop to manual.

The Field Communicator displays the loop test menu.

4. Select a discreet milliamp level for the controller to output. At the “Choose analog output” prompt, select *4 mA*, *20 mA*, or *Other* to manually input a value between 4 and 20 milliamps.
5. Check the reference meter to verify that it reads the value you commanded the controller to output. If the readings do not match, either the controller requires an output trim, or the meter is malfunctioning.

After completing the test procedure, the display returns to the loop test screen and allows you to choose another output value or end the test.

# Installation in Conjunction with a Rosemount 333 HART Tri-Loop HART-to-Analog Signal Converter

Use the DLC3010 digital level controller in operation with a Rosemount 333 HART Tri-Loop HART-to-Analog Signal Converter to acquire an independent 4-20 mA analog output signal for the process variable, % range, electronics temperature, and process temperature. The Tri-Loop divides the digital signal and outputs any or all of these variables into as many as three separate 4-20 mA analog channels.

Refer to figure 2-13 for basic installation information. Refer to the 333 HART Tri-Loop HART-to-Analog Signal Converter Product Manual ([00809-0100-4754](http://www.rosemount.com/00809-0100-4754)) for complete installation information.

Figure 2-13. HART Tri-Loop Installation Flowchart

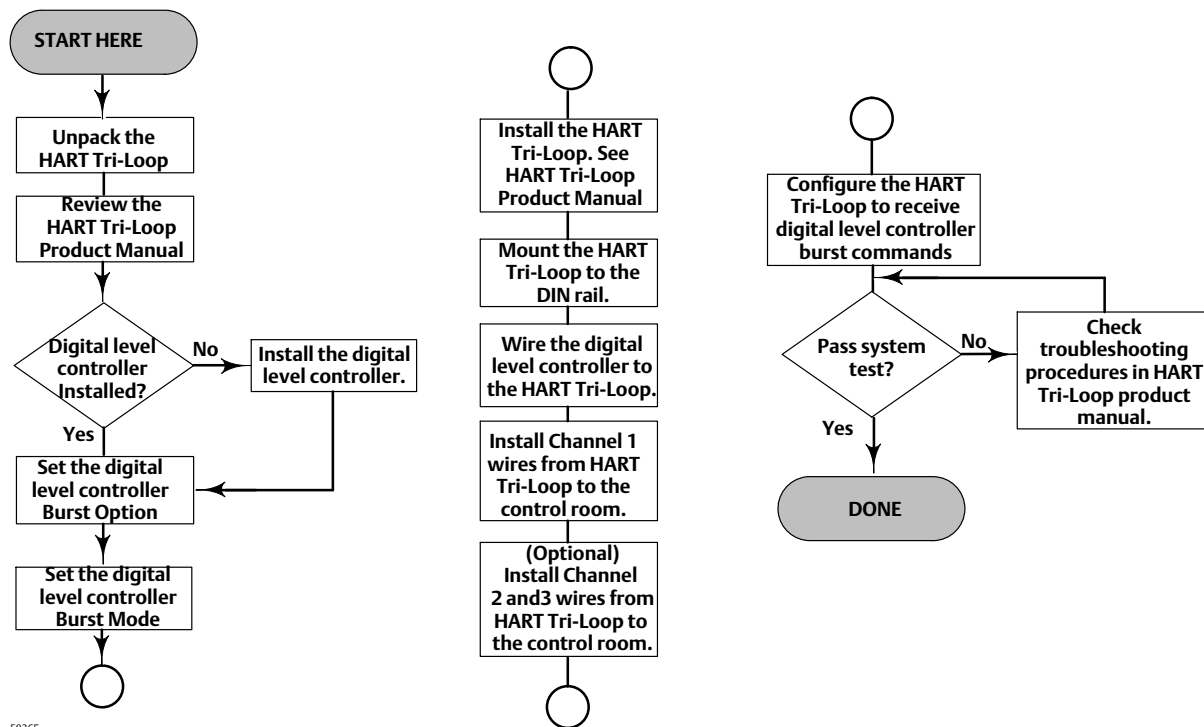

E0365

## Commissioning the Digital Level Controller for use with the HART Tri-Loop

To prepare the digital level controller for use with a 333 HART Tri-Loop, you must configure the digital level controller to burst mode, and select the dynamic variables to burst. In burst mode, the digital level controller provides digital information to the HART Tri-Loop HART-to-Analog Signal Converter. The HART Tri-Loop converts the digital information to a 4-20 mA analog signal. The HART Tri-Loop divides the signal into separate 4-20 mA loops for the primary (PV), secondary (SV), tertiary (TV), and quaternary (QV) variables. Depending upon the burst option selected, the digital level controller will burst the variables as shown in table 2-1.

The DLC3010 status words are available in the HART Burst messages. However, the Tri-Loop cannot be configured to monitor them directly.

To commission a DLC3010 digital level controller for use with a HART Tri-Loop, perform the following procedure.

Table 2-1. Burst Variables Sent by the FIELDVUE DLC3010

Burst Option	Variable	Variable Burst <sup>(1)</sup>	Burst Command
Read PV	Primary	Process variable (EU)	1
Read PV mA and % Range	Primary	Process variable (mA)	2
	Secondary	Percent range (%)	
Read Dynamic Vars	Primary	Process variable (EU)	3
	Secondary	Electronics temperature (EU)	
	Tertiary	Process temperature (EU)	
	Quaternary	Not used	

1. EU—engineering units; mA—current in milliamperes; %—percent

### Set the Burst Operation

Field Communicator	Configure > Communications > Burst Option (2-4-2)
--------------------	---

1. Access *Burst Option*.
2. Select the desired burst option and press *ENTER*
3. Access *Burst Mode* and select *On* to enable burst mode. Press *ENTER*.
4. Select *SEND* to download the new configuration information to the digital level controller.

## Section 3 Overview

### Overview

Field Communicator	Overview (1)
--------------------	--------------

### Device Status

*Good* There are no active alerts and instrument is In Service.

*Failed* The highest severity active alert is in the Failed category.

*Maintenance* The highest severity active alert is in the Maintenance category.

*Advisory* The highest severity active alert is in the Advisory category.

### Comm Status

*Polled* Communication with Digital Level Controller is established. Burst mode is turned off.

*Burst* Provides continuous communication from the digital level controller. Burst mode applies only to the transmission of burst mode data and does not affect the way other data is accessed.

### PV is

Indicates the type of measurement either level, interface (the interface of two liquids of different specific gravities), or density (measures the liquid specific gravity). The process variable displayed and measured depends on the entry for "PV is" under PV Setup.

### Primary Variable

*PV Value* Displays the process variable (level, interface, or density) in engineering units.

*% Range* Displays the process variable as a percent of span (determined by the LRV and URV).

### AO

Indicates the current analog output value of the instrument, in milliamperes.

## Process Temperature

Proc Temp Source— Manual or RTD

Proc Temp— indicates the process temperature.

## Device Information

### Identification

Follow the prompts on the Field Communicator display to view the following information.

- **HART Tag**— a unique name (up to eight characters) that identifies the physical instrument.
- **Distributor**— identifies the distributor of the instrument.
- **Model**— identifies the instrument model; ie. DLC3010.
- **Device ID**— each instrument has a unique Device Identifier. The Device ID provides additional security to prevent this instrument from accepting commands meant for other instruments.
- **Date**— user-defined variable that provides a place to save the date of the last revision of configuration or calibration information.
- **Descriptor**— a longer user-defined electronic label to assist with more specific controller identification that is available with the HART tag.
- **Message**— user-defined means for identifying individual controllers in multi-controller environments.

### Revisions

Follow the prompts on the Field Communicator display to view revision information.

- **HART Universal Revision**— the revision number of the HART Universal Commands which are used as the communications protocol for the instrument.
- **Field Device Revision**— the revision of the protocol for interfacing to the functionality of the instrument.
- **Firmware Revision**— the revision number of the Fisher software in the instrument.
- **Hardware Revision**— the revision number of the Fisher instrument hardware.
- **DD Information**— the revision level of the Device Description used by the Field Communicator while communicating with the instrument.

## Alarm Type and Security

### Alarm Type

- **Alarm Jumper**— displays the position of the hardware alarm jumper, either high current or low current.
- **Display Alert/Saturation Level**

### Security

- **Write Lock**
- **Write Lock Setup**

To setup and calibrate the instrument, write lock must be set to *Writes Enabled*. (Write Lock is reset by a power cycle. If you have just powered up the instrument Writes will be enabled by default.) In AMS, go to Device Information in the Overview page. Select the Alarms tab to change the write lock.





## Section 4 Configuration and Calibration

### Initial Setup

If a DLC3010 digital level controller ships from the factory mounted on a 249 sensor, initial setup and calibration is not necessary. The factory enters the sensor data, couples the instrument to the sensor, and calibrates the instrument and sensor combination.

---

#### Note

If you received the digital level controller mounted on the sensor with the displacer blocked, or if the displacer is not connected, the instrument will be coupled to the sensor and the lever assembly unlocked. To place the unit in service, if the displacer is blocked, remove the rod and block at each end of the displacer and check the instrument calibration. (If the “factory cal” option was ordered, the instrument will be precompensated to the process conditions provided on the requisition, and will not appear to be calibrated if checked against room temperature 0 and 100% water level inputs).

If the displacer is not connected, hang the displacer on the torque tube.

If you received the digital level controller mounted on the sensor and the displacer is not blocked (such as in skid mounted systems), the instrument will not be coupled to the sensor, and the lever assembly will be locked. Before placing the unit in service, couple the instrument to the sensor, then unlock the lever assembly.

When the sensor is properly connected and coupled to the digital level controller, establish the zero process condition and run the appropriate zero calibration procedure under Partial Calibration. The Torque Rate should not need to be re-calibrated.

---

To review the configuration data entered by the factory, connect the instrument to a 24 VDC power supply as shown in figure 2-9. Connect the Field Communicator to the instrument and turn it on. Go to *Configure* and review the data under Manual Setup, Alert Setup, and Communications. If your application data has changed since the instrument was factory-configured, refer to the Manual Setup section for instructions on modifying configuration data.

For instruments not mounted on a level sensor or when replacing an instrument, initial setup consists of entering sensor information. The next step is coupling the sensor to the digital level controller. When the digital level controller and sensor are coupled, the combination may be calibrated.

Sensor information includes displacer and torque tube information, such as:

- Length units (meters, inches, or centimeters)
- Volume units (cubic inches, cubic millimeters, or milliliters)
- Weight units (kilograms, pounds, or ounce)
- Displacer Length
- Displacer Volume
- Displacer Weight
- Displacer Driver Rod Length (moment arm) (see table 4-1)

- Torque Tube Material

---

**Note**

A sensor with an N05500 torque tube may have NiCu on the nameplate as the torque tube material.

---

- Instrument mounting (right or left of displacer)
- Measurement Application (level, interface, or density)

## Configuration Advice

Guided Setup directs you through initialization of configuration data needed for proper operation. When the instrument comes out of the box, the default dimensions are set for the most common Fisher 249 construction, so if any data is unknown, it is generally safe to accept the defaults. The mounting sense - 'instrument left or right of displacer' - is important for correct interpretation of positive motion. The torque tube rotation is clockwise with rising level when the instrument is mounted to the right of the displacer, and counter-clockwise when mounted to the left of the displacer. Use Manual Setup to locate and modify individual parameters when they need to be changed.

## Preliminary Considerations

### Write Lock

Field Communicator	Overview > Device Information > Alarm Type and Security > Security > Write Lock (1-7-3-2-2)
--------------------	---

To setup and calibrate the instrument, write lock must be set to *Writes Enabled*. Write Lock is reset by a power cycle. If you have just powered up the instrument Writes will be enabled by default.

## Guided Setup

Field Communicator	Configure > Guided Setup > Instrument Setup (2-1-1)
--------------------	---

---

**Note**

Place the loop into manual operation before making any changes in setup or calibration.

---

Instrument Setup is available to aid initial setup. Follow the prompts on the Field Communicator display to enter information for the displacer, torque tube, and digital measurement units. Most of the information is available from the sensor nameplate, shown in figure 4-1. The moment arm is the effective length of the driver rod and depends upon the sensor type. For a 249 sensor, refer to table 4-1 to determine driver rod length. For a special sensor, refer to figure 4-2.

Figure 4-1. Example Sensor Nameplate

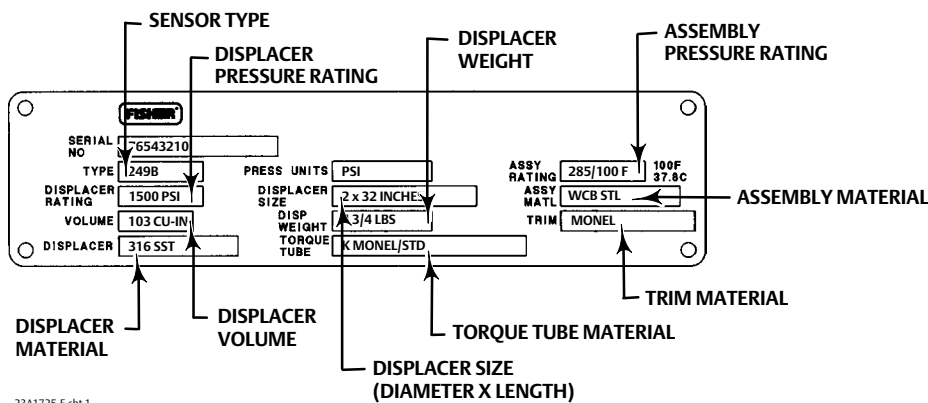

Table 4-1. Moment Arm (Driver Rod) Length<sup>(1)</sup>

SENSOR TYPE <sup>(2)</sup>	MOMENT ARM	
	mm	Inch
249	203	8.01
249B	203	8.01
249BF	203	8.01
249BP	203	8.01
249C	169	6.64
249CP	169	6.64
249K	267	10.5
249L	229	9.01
249N	267	10.5
249P (CL125-CL600)	203	8.01
249P (CL900-CL2500)	229	9.01
249VS (Special) <sup>(1)</sup>	See serial card	See serial card
249VS (Std)	343	13.5
249W	203	8.01

1. Moment arm (driver rod) length is the perpendicular distance between the vertical centerline of the displacer and the horizontal centerline of the torque tube. See figure 4-2. If you cannot determine the driver rod length, contact your [Emerson sales office](#) and provide the serial number of the sensor.  
 2. This table applies to sensors with vertical displacers only. For sensor types not listed, or sensors with horizontal displacers, contact your Emerson sales office for the driver rod length. For other manufacturers' sensors, see the installation instructions for that mounting.

1. Enter displacer length, weight, volume units and values, and driver rod (moment arm) length (in the same units chosen for displacer length) when prompted.
2. Choose Instrument Mounting (left or right of displacer, refer to figure 2-5).
3. Choose Torque Tube Material.

4. Select the measurement application (level, interface, or density).

**Note**

For interface applications, if the 249 is not installed on a vessel, or if the cage can be isolated, calibrate the instrument with weights, water, or other standard test fluid, in level mode. After calibrating in level mode, the instrument can be switched to interface mode. Then, enter the actual process fluid specific gravity(s) and range values.

If the 249 sensor is installed and must be calibrated in the actual process fluid(s) at operating conditions, enter the final measurement mode and actual process fluid data now.

Figure 4-2. Method of Determining Moment Arm from External Measurements

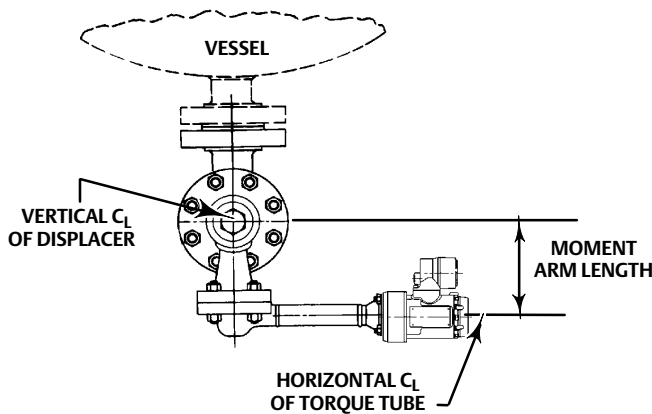

- a. If you choose “Level” or “Interface,” the default process variable units are set to the same units chosen for displacer length. You are prompted to key in the level offset. Range values will be initialized based on Level Offset and displacer size. The default upper range value is set to equal the displacer length and the default lower range value is set to zero when the level offset is 0.
- b. If you choose “Density,” the default process variable units are set to “SGU” (Specific Gravity Units). The default upper range value is set to “1.0” and the default lower range value is set to “0.1”.

5. Select the desired output action: Direct or Reverse

Choosing “reverse acting” will swap the default values of the upper and lower range values (the process variable values at 20 mA and 4 mA). In a reverse acting instrument, the loop current will decrease as the fluid level increases.

6. You are given the opportunity to modify the default value for the process variable engineering units.
7. You are then given the opportunity to edit the default values that were entered for the upper range value (PV Value at 20 mA) and lower range value (PV Value at 4 mA).
8. The default values of the alarm variables will be set as follows:

Direct-Acting Instrument (Span = Upper Range Value - Lower Range Value)	
Alarm Variable	Default Alarm Value
Hi-Hi Alarm	Upper Range Value
Hi Alarm	95% span + Lower Range Value
Lo Alarm	5% span + Lower Range Value
Lo-Lo Alarm	Lower Range Value

Reverse-Acting Instrument (Span = Lower Range Value - Upper Range Value)	
Alarm Variable	Default Alarm Value
Hi-Hi Alarm	Lower Range Value
Hi Alarm	95% span + Upper Range Value
Lo Alarm	5% span + Upper Range Value
Lo-Lo Alarm	Upper Range Value

PV alert thresholds are initialized at 100%, 95%, 5% and 0% span.

PV alert deadband is initialized to 0.5% span.

PV alerts are all disabled. Temperature alerts are enabled.

- If Density mode was chosen, setup is complete.
- If Interface or Density mode was chosen, you are prompted to enter the specific gravity of the process fluid (if interface mode, the specific gravities of the upper and lower process fluids).

---

**Note**

If you are using water or weights for calibration, enter a specific gravity of 1.0 SGU. For other test fluids, enter the specific gravity of the fluid used.

---

For temperature compensation, go to *Manual Setup*. Under *Process Fluid* select *View Fluid Tables*. Temperature compensation is enabled by entering values into the fluid tables. Two data tables are available that may be entered in the instrument to provide specific gravity correction for temperature (see tables 4-2 and 4-3). For interface level applications, both tables are used. For level measurement applications, only the lower specific gravity table is used. Neither table is used for density applications. Both tables may be edited during detailed setup.

---

**Note**

The existing tables may need to be edited to reflect the characteristics of the actual process fluid.

---

- You can accept the current table(s), modify an individual entry, or enter a new table manually. For an interface application, the user can switch between the upper and lower fluid tables.

## Coupling

If the digital level controller is not already coupled to the sensor, perform the following procedure to couple the digital level controller to the sensor.

1. Slide the access handle to the locked position to expose the access hole. Press on the back of the handle as shown in figure 2-4 then slide the handle toward the front of the unit. Be sure the locking handle drops into the detent.
2. Set the displacer to the lowest possible process condition, (i.e. lowest water level or minimum specific gravity) or replace the displacer by the heaviest calibration weight.

---

### Note

Interface or density applications with displacer/torque tube sized for a small total change in specific gravity are designed to be operated with the displacer always submerged. In these applications, the torque rod is sometimes resting on a stop while the displacer is dry. The torque tube does not begin to move until a considerable amount of liquid has covered the displacer. In this case, couple with the displacer submerged in the fluid with the lowest density and the highest process temperature condition, or with an equivalent condition simulated by the calculated weights.

If the sizing of the sensor results in a proportional band greater than 100% (total expected rotational span greater than 4.4 degrees), couple the transmitter to the pilot shaft while at the 50% process condition to make maximum use of available transmitter travel ( $\pm 6^\circ$ ). The Capture Zero procedure is still performed at the zero buoyancy (or zero differential buoyancy) condition.

---

3. Insert a 10 mm deep well socket through the access hole and onto the torque tube shaft clamp nut. Tighten the clamp nut to a maximum torque of 2.1 N•m (18 lbf•in).
4. Slide the access handle to the unlocked position. (Press on the back of the handle as shown in figure 2-4 then slide the handle toward the rear of the unit.) Be sure the locking handle drops into the detent.

## Manual Setup

The DLC3010 digital level controller has the capability to communicate via the HART protocol. This section describes the advanced features that can be accessed with the Field Communicator.

---

### Note

Changing setup parameters may require enabling writing to the instrument with the Field Communicator (Overview > Device Information > Alarm Type and Security > Security > Write Lock Setup). Select *Writes Enabled* to enable writing setup and calibration data, or select *Writes Disabled* to disable writing data. Note that cycling power will clear the Write Lock condition to “Writes Enabled”.

---

## Sensor

Field Communicator	Configure > Manual Setup > Sensor (2-2-1)
--------------------	---

### Sensor Units

Follow the prompts on the Field Communicator to enter the desired sensor units.

- **Length Units**— Permits setting the units of measure for the displacer length (in feet, meters, inches, or centimeters).
- **Volume Units**— Permits setting the units of measure for the displacer volume (in liters, cubic inches, cubic millimeters, or milliliters).
- **Weight Units**— Permits setting the units of measure for the displacer weight (in grams, kilograms, pounds, or ounces).
- **Torque Rate Units**— Permits setting the torque rate units (in lbf-in per deg—pounds-force inches per degree rotation; newton-m per deg—newton-meters per degree rotation; or dyne-cm per deg—dyne-centimeters per degree rotation).
- **Temperature Units**— Select either *degC* (degrees centigrade) or *degF* (degrees Fahrenheit) to enter the temperature units. Note that when using degF, the Temperature Alert Deadband parameter is incorrectly displayed with a 32° bias.

### Sensor Dimensions

Follow the prompts on the Field Communicator to enter the sensor dimensions. Dimensions can be found on the sensor name plate as shown in figure 4-1.

- **Displacer Length**— Enter the displacer length from the sensor nameplate.
- **Displacer Volume**— Enter the displacer volume from the sensor nameplate.
- **Displacer Weight**— Enter the displacer weight from the sensor nameplate.

- **Driver Rod Length**— Enter the displacer rod length. The displacer rod length depends upon the sensor type. For a 249 sensor, obtain the displacer rod length from table 4-1 or from the Field Communicator Help. Refer to figure 4-2 to physically measure this value.

## Torque Tube

Follow the prompts on the Field Communicator to enter torque tube data.

- **Torque Rate**— Displays the torque rate currently stored in the instrument.

**Change Torque Rate**— Permits changing the torque rate stored in the instrument.

- **TT Material**— Displays the torque tube material currently stored in the instrument.

---

### Note

A sensor with an N05500 torque tube may have NiCu on the nameplate as the torque tube material.

---

**TT Comp Selection**— Torque Tube Compensation Selection permits changing the torque tube material stored in the instrument.

- **TT Comp Table**— Torque Tube Compensation Table permits you to load a table with the material temperature coefficients.

---

### Note

In firmware version 07 and 08, the data tables for torque-tube correction are simply stored without implementation. The information may be used to pre-compensate the measured torque-tube rate manually.

---

## Instrument Mounting

Follow the prompts on the Field Communicator display to specify if the instrument is to the right or left of the displacer. See figure 2-5.

## Sensor Damping

Follow the prompts on the Field Communicator display to configure the input filter.

Time constant for the input filter, in seconds, for the A/D measurement. The filter is applied before PV processing, after the A/D conversion. Range is 0 to 16 seconds in 0.1 second increments. The default value is 0.0 seconds. To disable the filter, set the time constant to 0 seconds. This filter is provided for extreme input noise situations. Use of this filter normally should not be necessary.

Net instrument response is a combination of analog input filtering and output filtering.



## Variables

Field Communicator	Configure > Manual Setup > Variables (2-2-2)
--------------------	--

### Primary Variables

Follow the prompts on the Field Communicator to view or edit Primary Variable information.

- **PV is**— Display the PV assignment currently stored in the instrument.

**Change PV**— Follow the prompts to change the PV assignment. Select Level Units if the PV is level, Interface Units if the PV is Interface, or Density Units if the PV is Density.

---

#### Note

If the PV assignment is changing to Level or Interface, go to the Process Fluid(s) menu and edit the configuration data for fluid density before returning the loop to Auto.

---

- **PV Units**— Permits changing the PV units.

For density measurement:

- g/cm<sup>3</sup>—grams per cubic centimeter
- kg/m<sup>3</sup>—kilograms per cubic meter
- lb/gal—pounds per gallon
- lb/ft<sup>3</sup>—pounds per cubic foot
- g/mL—grams per milliliter
- kg/L—kilograms per liter
- g/L—grams per liter
- lb/in<sup>3</sup>—pounds per cubic inch
- SGU—specific gravity units

For level and interface measurement:

- ft—feet
- m—meters
- in—inches
- cm—centimeters
- mm—millimeters

- **Level Offset**— The Primary Variable value you want the instrument to report when physical level is at the bottom of displacer.

**Set Level Offset**— Adding a level offset permits the process variable value in engineering units to be reported with respect to a reference point other than the bottom of the displacer (see figure 4-3). Examples include: bottom of the process vessel, the process set point, or sea level. Set Level Offset is only available in Level or Interface measurement mode. Follow the prompts on the Field Communicator to enter the offset value. The procedure will offer to shift the range values and alert thresholds by the amount of the level offset for you. This will keep the 4-20 mA output aligned with the top and bottom of the displacer. If you have already shifted the range values and alert thresholds to account for the effect of the offset you are adding select No when asked if you want to 'Proceed changing range values and alert thresholds'.

Figure 4-3. Example of the Use of Level Offset

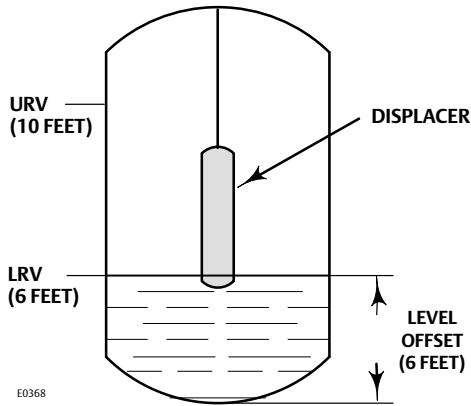

## Sensor Limits

Follow the prompts on the Field Communicator to view sensor limit information.

- **Upper Sensor Limit**— Indicates the maximum usable value for the Upper Range Value.
- **Lower Sensor Limit**— Indicates the minimum usable value for the Lower Range Value.
- **Minimum Span**— Difference between the Upper Range Value and the Lower Range Value below which amplification of instrument errors may become a concern. This effect should be considered when sizing displacer / torque tube.

## Primary Variable Range

Follow the prompts on the Field Communicator to view or edit range information.

- **Upper Range Value**— Defines the operational end point from which the Analog Value and the 100% point of the percent range are derived.
- **Lower Range Value**— Defines the operational end point from which the Analog Value and the 0% point of the percent range are derived.

**View/Change AO Action**— Follow the prompt and change the output action: Direct/Reverse.

For Reverse action, the Upper Range Value and Lower Range Value will be swapped.

## PV Damping

PV Damping changes the response time of the controller to smooth variations in output readings caused by rapid changes in input. Determine the appropriate damping setting based on the necessary response time, signal stability, and other requirements of the loop dynamics of your system. The default damping value is 0.2 seconds, and can be reset to any value between 0 and 16 seconds in 0.1 second increments. When set to 0, the damping function is off.

Net instrument response is a combination of analog input filtering and output filtering.

## Process Fluid

Field Communicator	Configure > Manual Setup > Process Fluid (2-2-3)
--------------------	--

---

### Note

Process Fluid is only visible if PV is Level or Interface.

---

## Process Fluid

Follow the prompts on the Field Communicator to view or edit process fluid information.

- **Upper Fluid Density**— Indicates the density of the upper fluid.
- 

### Note

Upper Fluid Density is only visible if PV is Interface.

---

- **Lower Fluid Density**— Indicates the density of the lower fluid.
- **View Fluid Tables**

*Upper Density Table* (only visible if PV is Interface)

*Lower Density Table*

Two specific gravity tables are available in the instrument to provide specific gravity correction for temperature. For level measurement applications, only the lower specific gravity table is used. For interface applications, both the upper and lower table can be displayed and edited. For density applications, no specific gravity correction table is presented. Example entries for saturated water are given in table 4-2. Figure 4-4 shows the curve that results when these values are plotted.

Table 4-2. Example Specific Gravity vs Temperature Table for Saturated Water

Data Point	Temperature		Specific Gravity
	°C	°F	
1	26.7	80.0	0.9985
2	93.3	200.0	0.9655
3	176.7	350.0	0.8935
4	248.9	480.0	0.8040
5	304.4	580.0	0.7057
6	337.8	640.0	0.6197
7	354.4	670.0	0.5570
8	365.6	690.0	0.4940
9	371.1	700.0	0.4390
10	374.7	706.5	0.3157

Figure 4-4. Example Saturated Water Curve Plotted with Values from Table 4-2

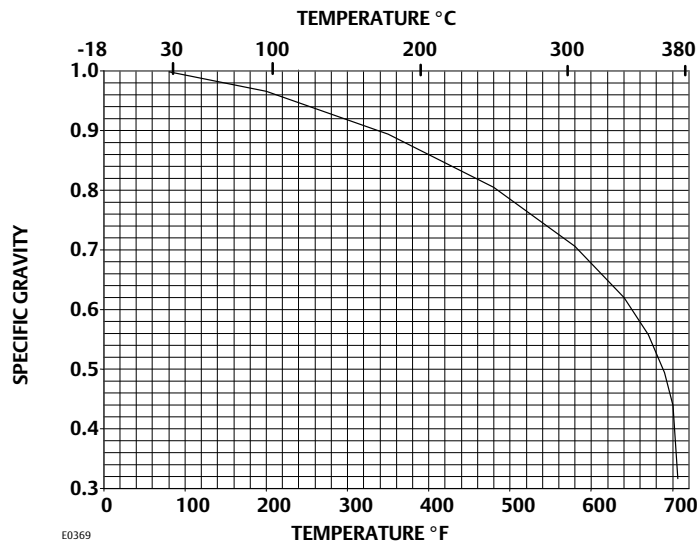

You can enter up to 10 temperature and specific gravity pairs in the table. The table entry function is terminated by entering zero for the specific gravity. Keep this in mind when setting up a table for a upper fluid, such as steam, whose specific gravity approaches 0 at lower temperatures.

The resolution of the table entry for specific gravity is 5 decimal places. This means the smallest specific gravity value you can enter is 0.00001, which should be sufficient to allow a starting temperature around 15.6 °C (60 °F) for the steam specific gravity table.

The example set of tables given are generated by visually laying linear segments over a reference curve, and are not guaranteed to provide any particular accuracy. They are provided to illustrate the guidelines for developing your own table.

1. Establish a table for the fluid(s) you are using over the expected operating range of process temperature. This allows you to make best use of the maximum of ten points to obtain the accuracy you require. If your fluid specific gravity is very linear over the operating temperature range, two data points may be sufficient. (The correction algorithm provides linear interpolation between data points, and bounds the result at the table end points.)
2. Pick points closer together in regions of higher slope.
3. Pick linear segments that distribute the error equally on each side of the true curve.

Enter values in the specific gravity tables.

**Enter Constant Density**— Define fluid density/densities by constant values. No temperature compensation is applied.

**Measure Density**

**Note**

Measure Density is only available if PV is Level.

If specific gravity information for the process fluid is not available, an instrument and sensor combination that has been previously calibrated can be used to measure the fluid density. You must be able to manipulate the level and externally measure it to have the instrument measure the specific gravity. First capture a new zero reference angle at the zero process condition for the unknown fluid(s), then run this procedure. If the actual process application is Level, use a test level near 100% when measuring SG. If the actual process application is interface, the best differential SG measurement will be obtained at 50% interface level. Follow the prompts on the Field Communicator and the following procedure to measure specific gravity:

1. Set the control loop for manual control.
2. Adjust the liquid level as close as possible to the optimum value discussed above.
3. Enter the externally measured level, in engineering units.

After you press OK on the Field Communicator, the instrument begins calculating the specific gravity. You can then elect to use this value as the specific gravity for all level measurements. If you select *No*, the instrument uses the specific gravity entered under PV Setup, or the values from the specific gravity tables.

4. When finished measuring specific gravity, return the control loop to automatic control.

- **Load Steam Tables**

**Note**

Load Steam Tables is only visible if PV is Interface.

Table 4-3 lists example entries for saturated steam. Figure 4-5 is the curve that results when these values are plotted.

**Table 4-3. Example Specific Gravity vs Temperature Table for Saturated Steam**

DATA POINT	TEMPERATURE		SPECIFIC GRAVITY
	°C	°F	
1	126.7	260	0.00095
2	210.0	410	0.00850
3	271.1	520	0.02760
4	304.4	580	0.04900
5	326.7	620	0.07200
6	343.3	650	0.09800
7	357.8	676	0.13500
8	365.6	690	0.16800
9	371.1	700	0.21000
10	374.4	706	0.31570

Figure 4-5. Example Saturated Steam Curve Plotted from Values in Table 4-3

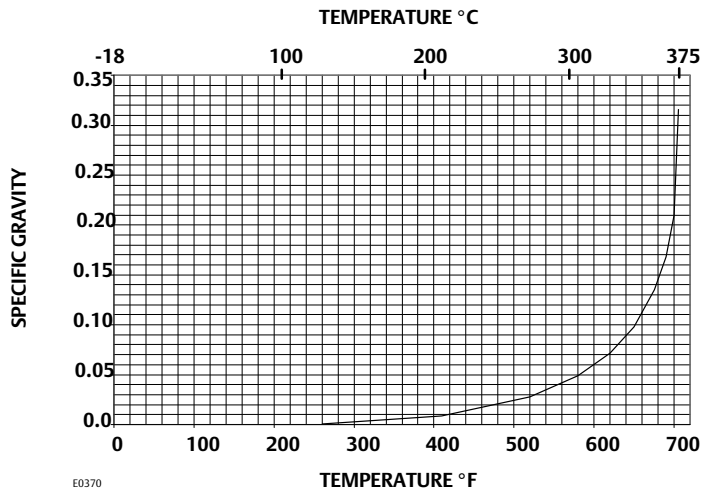

## Process Temperature

The digital level controller can receive the process temperature from a resistance temperature detector (RTD) connected to the unit or, if no RTD is connected to the unit, you can enter the process temperature directly. The digital level controller uses the process temperature to make specific gravity corrections. Follow the prompts on the Field Communicator to view or edit process temperature information.

- Proc Temp Source— Manual or RTD

Change Proc Temp Source— Select Keep Value, Edit Value, or Install RTD.

You must select the number of wires for an RTD; either 2 or 3.

For a 2-wire RTD, you must specify the connecting wire resistance for one wire of the pair. If you know the resistance, select *Resistance* and enter the resistance of the wire. 250 feet of 16 AWG wire has a resistance of 1 ohm. If you do not know the resistance manually compute the value from a wire resistance table, or temporarily short the two wires at one end of the cable, measure the resistance at the other end, and divide by two.

### Note

For DD Rev 3 and earlier, the algorithm provided in this procedure for calculating wire resistance does not compute the correct value for size 16 AWG, hence the need to manually compute the resistance. This issue will be fixed in DD Rev 4.

- Proc Temp— Display the process temperature.
- RTD Wire Resistance— Displays the user estimate of wiring resistance (per lead) when employing a 2-wire RTD connection.

## Device Information

Field Communicator	Configure > Manual Setup > Device Information (2-2-4)
--------------------	---

Follow the prompts on the Field Communicator display to view or edit information in the following fields.

- **HART Tag**— The HART tag is the easiest way to identify and distinguish between controllers in multi-controller environments. Use the HART tag to label controllers electronically according to the requirements of your application. The tag you define is automatically displayed when a HART-based communicator establishes contact with the controller at power-up. The tag may be up to eight characters long and has no impact on the primary variable readings of the controller.
- **Date**— Date is a user-defined variable that provides a place to save the date of the last revision of configuration or calibration information. It has no impact on the operation of the controller or Field Communicator. Enter a date with the format MM/DD/YYYY.
- **Descriptor**— The Descriptor provides a longer user-defined electronic label to assist with more specific controller identification that is available with the HART tag. The descriptor may be up to 16 characters long and has no impact on the operation of the controller or HART-based communicator.
- **Message**— Message provides the most specific user-defined means for identifying individual controllers in multi-controller environments. It allows for 32 characters of information and is stored with the other configuration data. Message has no impact on the operation of the controller or the Field Communicator.
- **Polling Address**— If the digital level controller is used in a point-to-point configuration, the Polling Address is 0. When several devices are connected in the same loop, each device must be assigned a unique polling address. The Polling Address may be set to a value between 0 and 15. A device with polling address greater than 0 will operate in Multi-Drop mode, with output current fixed. Any process information from a device in Multi-Drop mode must be obtained via HART communication.

For the Field Communicator to be able to communicate with a device whose polling address is not 0, it must be configured to automatically search for all or specific connected devices.

- **Serial Numbers**— Follow the prompts on the Field Communicator display to enter or view the following serial numbers.

**Instrument Serial Number**— Use this field to enter or view the serial number on the instrument nameplate, up to 12 characters.

**Sensor Serial Number**— Use this field to enter or view the sensor serial number. The sensor serial number is found on the sensor nameplate.

**Final Assembly Number**— A number that can be used to identify the instrument and sensor combination.

## Instrument Display

Field Communicator	Configure > Manual Setup > Instrument Display (2-2-5)
--------------------	---

Follow the prompts on the Field Communicator display to view or edit what is visible in the instrument display.

- **LCD Configuration**— Select this parameter to indicate if the meter is installed. If the meter is physically installed, select *Installed*, then send the change to the instrument. When switching the setting from 'Not Installed' to 'Installed', the meter display will be activated immediately. However, if you change the setting to 'Not Installed'

from 'Installed' just to disable the display without physically removing the meter, a device reset or power cycle will be required before the setting takes effect. The meter must be installed before you can set the display type or the decimal places.

- **Display Mode**—Only visible if the meter is installed.

**Change Display Mode**— Select the type of information the meter should display and how it should be displayed by selecting 'Change display mode'. You can select for display:

**PV**— Displays the process variable (level, interface, or density) in engineering units.

**PV/Process Temperature**— Alternately displays the process variable in engineering units, the process temperature in the units selected under *Temp Units* (PV Setup), and the degrees of torque tube rotation.

**% Range**— Displays the process variable as a percent of span (determined by the LRV and URV).

**PV/% Range**— Alternately displays the process variable in engineering units and the process variable in percent of span.

- **Decimal Places**—Selects the number of decimal places to display, up to four. Setting the value to zero puts the display in auto-scale mode. It will then display as many decimal places as will fit.

If *PV/Proc Temp* or *PV/% Range* is selected, the display alternates every two seconds between the selected readings. The meter also simultaneously displays the analog output signal using a percent of scale bar graph around the perimeter of the display face as shown in figure 4-6, no matter what display type is selected.

Figure 4-6. LCD Meter Display

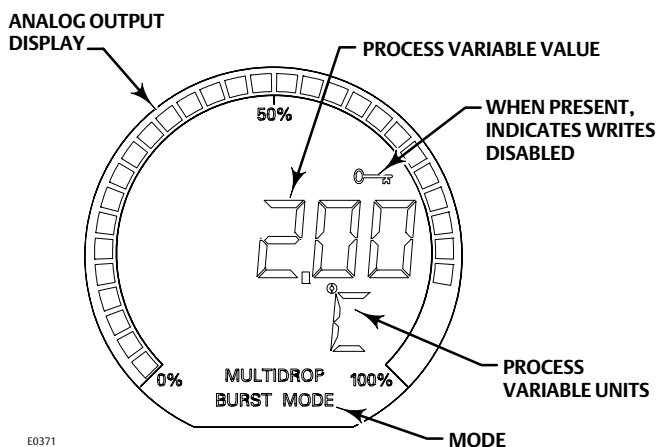

After you have selected the desired meter settings, press *SEND* on the Field Communicator to download the meter settings to the instrument.



## Alert Setup

The following menus are available for configuring Alerts.

### Primary Variable

Field Communicator	Configure > Alert Setup > Primary Variable (2-3-1)
--------------------	--

Follow the prompts on the Field Communicator display to view or edit the following primary variable alerts.

#### Primary Variable Hi

- **Hi Alert**

**PV Hi Alert Enable**— On or Off. PV High Alert Enable activates checking the primary variable against the PV High Alert limit. The High Alert is set if the primary variable rises above the PV High Alert limit. Once the alert is set, the primary variable must fall below the PV High Alert limit by the PV Alerts Threshold Deadband before the alert is cleared. See figure 4-7.

**PV Hi Alert Threshold**— Primary Variable Hi Alert Threshold is the value of the process variable, in engineering units, which, when exceeded, sets the Primary Variable High Alert.

**PV Hi Alert Threshold**— Method to change the PV Hi Alert Threshold

- **Hi Hi Alert**

**PV Hi Hi Alert Enable**— On or Off. PV High High Alert Enable activates checking the primary variable against the PV High-High Alert limit. The High High Alert is set if the primary variable rises above the PV High High Alert limit. Once the alert is set, the primary variable must fall below the PV High High Alert limit by the PV Alerts Threshold Deadband before the alert is cleared. See figure 4-7.

**PV HiHi Alert Threshold**— Primary Variable HiHi Alert Threshold is the value of the process variable, in engineering units, which, when exceeded, sets the Primary Variable High-High Alert.

**PV HiHi Alert Threshold**— Method to change the PV HiHi Alert Threshold

---

#### Note

If the Hi Hi Alert is enabled and set, the digital level controller output will go to below 3.75 mA or above 21.0 mA, depending on the position of the alarm jumper.

Consider the effect of an alarm annunciation on the process, then set alarm jumper position accordingly.

When Output Action is 'Direct':

- A Hi alarm setting will result in an alarm-state output consistent with a very high process.
- A Lo alarm setting will result in an alarm-state output consistent with a very low process.

When Output Action is 'Reverse', these relationships are swapped.

In a Multi-Drop network (device has a non-zero Polling Address) alarm annunciation is disabled and the device is not directly driving any effector, so jumper setting is not a concern.

---

## Primary Variable Lo

- **Lo Alert**

**PV Lo Alert Enable**— On or Off. PV Lo Alert Enable activates checking the primary variable against the PV Lo Alert limit. The Lo Alert is set if the primary variable rises above the PV Lo Alert limit. Once the alert is set, the primary variable must fall below the PV Lo Alert limit by the PV Alerts Threshold Deadband before the alert is cleared. See figure 4-7.

**PV Lo Alert Threshold**— Primary Variable Lo Alert Threshold is the value of the primary variable, in engineering units, which, when exceeded, sets the Primary Variable Low Alert.

**PV Lo Alert Threshold**— Method to change the PV Lo Alert Threshold

- **Lo Lo Alert**

**PV LoLo Alert Enable**— On or Off. PV Lo Lo Alert Enable activates checking the primary variable against the PV Lo Lo Alert limit. The Lo Lo Alert is set if the primary variable rises above the PV Lo Lo Alert limit. Once the alert is set, the primary variable must fall below the PV Lo Lo Alert limit by the PV Alerts Threshold Deadband before the alert is cleared. See figure 4-7.

**PV LoLo Alert Threshold**— Primary Variable LoLo Alert Threshold is the value of the primary variable, in engineering units, which, when exceeded, sets the Primary Variable Low-Low Alert.

**PV LoLo Alert Threshold** — Method to change the PV Lo Lo Alert Threshold

---

### Note

If the Lo Lo Alert is enabled and set, the digital level controller output will go to below 3.75 mA or above 21.0 mA, depending on the position of the alarm jumper.

Consider the effect of an alarm annunciation on the process, then set alarm jumper position accordingly.

When Output Action is 'Direct':

- A Hi alarm setting will result in an alarm-state output consistent with a very high process.
- A Lo alarm setting will result in an alarm-state output consistent with a very low process.

When Output Action is 'Reverse', these relationships are swapped.

In a Multi-Drop network (device has a non-zero Polling Address) alarm annunciation is disabled and the device is not directly driving any effector, so jumper setting is not a concern.

---

**PV Value**— Current process variable (level, interface, or density) in engineering units.

**Upper Range Value**— Highest value of the primary variable that the digital level controller is currently configured to measure in the 4 to 20 mA loop.

**Lower Range Value** — Lowest value of the primary variable that the digital level controller is currently configured to measure in the 4 to 20 mA loop.

**PV Alerts Threshold Deadband** — The Primary Variable Alerts Threshold Deadband is the amount the primary variable, in engineering units, must change to clear a primary variable alert, once it has been set. The deadband applies to all the primary variable alarms. See figure 4-7.

---

### Note

For DD Rev 3 and lower, when changing the applied PV Deadband, the echoed value may not be displayed correctly in Length units other than inches and Density units other than pounds per cubic inch. Before editing this parameter, temporarily switch the PV

units to inches (or pounds per cubic inch), then restore the desired PV units after confirming the desired Deadband value. This issue will be fixed in DD Rev 4.

Figure 4-7. Process Variable Alert Threshold Deadband (Process Variable High Alert Example)

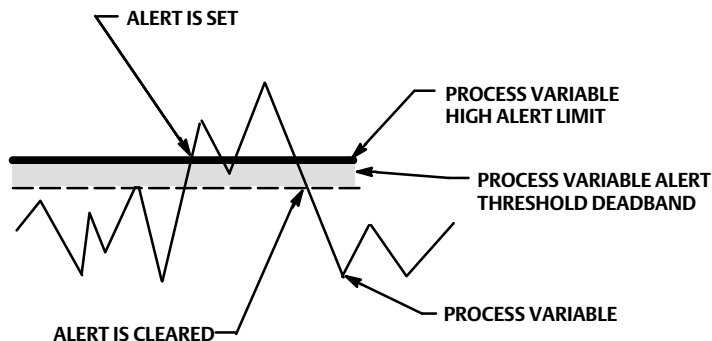

E0372

## Temperature

Field Communicator    Configure > Alert Setup > Temperature (2-3-2)

Follow the prompts on the Field Communicator display to set the following temperature alerts.

### Instrument Temperature

- Hi Alert

**Inst Temp Hi Alert Enable**— On or Off. Instrument Temperature High Alert Enable activates checking of the instrument temperature against the Instrument Temperature High Alert Threshold. Instrument Temperature High Alert is set if the instrument temperature rises above the Instrument Temperature High Alert Threshold. Once the alarm is set, the instrument must fall below the Instrument Temperature High Alert Threshold by the Temperature Deadband before the alarm is cleared. See figure 4-8.

**Inst Temp Hi Alert Threshold**— Instrument Temperature High Alert Threshold is the instrument electronics temperature, in temperature units, which, when exceeded, will set the Electronics High Alert.

- Lo Alert

**Inst Temp Lo Alert Enable**— On or Off. Instrument Temperature Low Alert Enable activates checking of the instrument temperature against the Instrument Temperature Low Alert Threshold. Instrument Temperature High Alert is set if the instrument temperature rises above the Instrument Temperature Low Alert Threshold. Once the alarm is set, the instrument must fall below the Instrument Temperature Low Alert Threshold by the Temperature Deadband before the alert is cleared. See figure 4-8.

**Inst Temp Lo Alert Threshold**— Instrument Temperature Low Alert Threshold is the instrument electronics temperature, in temperature units, which, when exceeded, will set the Electronics Low Alert.

- Inst Temp— Current Instrument Temperature.

- Inst Temp Offset— Offset to trim instrument temperature output to an independent reference. Factory calibration that may be modified by user.

Process Temperature

- Hi Alert

**Proc Temp Hi Alert Enable**— On or Off. Process Temperature High Alert Enable activates checking of the process variable temperature against the Process Temperature High Alert Threshold. The Process Temperature High Alert is set if the process variable temperature rises above the Process Temperature High Alert Threshold. Once the alert is set, the process variable temperature must fall below the Process Temperature High Alert Threshold by the Temperature Deadband before the alert is cleared. See figure 4-8.

**Proc Temp Hi Alert Threshold**— Process Temperature High Alert Threshold is the process variable temperature, in temperature units, which, when exceeded, will set the Process Temperature High Alert.

- Lo Alert

**Proc Temp Lo Alert Enable**— On or Off. Process Temperature Low Alert Enable activates checking of the process variable temperature against the Process Temperature Low Alert Threshold. The Process Temperature Low Alert is set if the process variable temperature rises above the Process Temperature Low Alert Threshold. Once the alert is set, the process variable temperature must fall below the Process Temperature Low Alert Threshold by the Temperature Deadband before the Alert is cleared. See figure 4-8.

**Proc Temp Lo Alert Threshold**— Process Temperature Low Alert Threshold is the process variable temperature, in temperature units, which, when exceeded, will set the Temperature Low Alert.

- **Proc Temp**— Displays the process temperature stored in the instrument.
- **Proc Temp Offset**— Bias to improve the accuracy of the (RTD) temperature measurement used to provide compensation for process-temperature-related density changes.
- **Temperature Deadband**— The Temperature Deadband is the amount the temperature, in temperature units, must change to clear a temperature alert, once it has been set. The deadband applies to all the temperature alerts. See figure 4-8. In firmware revision 8, the Temp Alert Offset is displayed incorrectly when the units are DegF. (The number displayed is 32 more than the actual deadband.)

**Note**

For DD Rev 3 and earlier, switch temperature units to Deg C before editing this parameter, then switch back to the desired temperature units after confirming the Deadband value.

Figure 4-8. Process Temperature Alert Threshold Deadband (Temperature High Alert Example)

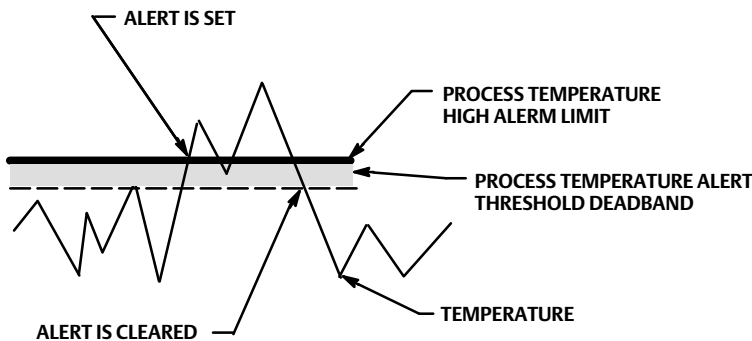

E0373

# Communications

Field Communicator    Configure > Communications > Burst Mode (2-4-1) or Burst Option (2-4-2)

## Burst Mode

Enabling burst mode provides continuous communication from the digital level controller.

**Note**

It may be difficult to make configuration adjustments to the DLC3010 while it is in burst mode, due to an increase in communication errors. To reconfigure the device, it is advisable to first disable burst mode.

Depending upon the burst option selected, the digital level controller will burst the variables as shown in table 2-1.

**Table 4-4. Burst Variables Sent by the FIELDVUE DLC3010**

Burst Option	Variable	Variable Burst <sup>(1)</sup>	Burst Command
Read PV	Primary	Process variable (EU)	1
Read PV mA and % Range	Primary	Process variable (mA)	2
	Secondary	Percent range (%)	
Read Dynamic Vars	Primary	Process variable (EU)	3
	Secondary	Electronics temperature (EU)	
	Tertiary	Process temperature (EU)	
	Quaternary	Not used	

1. EU—engineering units; mA—current in milliamperes; %—percent

## Burst Option

1. Select *On* in the Burst Mode menu; press *ENTER* to enable Burst Mode.
2. Select the desired option from the Burst Option menu and press *ENTER*.
3. Press *SEND* to download the new configuration information to the digital level controller.

# Calibration

## Introduction: Calibration of Smart Instruments

Analog instruments generally have only one interface that can be calibrated by the user. A zero and span output calibration is normally performed at the corresponding two input conditions. Zero/Span calibration is very simple to use, but provides little versatility. If the 0% and 100% input conditions are not available to the user, a calibration can sometimes be accomplished, but the gain and offset adjustments will likely interact, requiring considerable iteration to achieve accuracy. In contrast, intelligent instruments have many interfaces that can be calibrated or scaled by the user, with consequent increased versatility.

Refer to table 4-5 for a list of relationships in the DLC3010 that can be calibrated or configured by the user. Note that not all relationships are listed here.

**Table 4-5. Relationships in the FIELVUE DLC3010 that can be User Calibrated or Configured**

Torque Tube Rate	The scale factor between the internal digital representation of the measured pilot shaft rotation and the physical torque input to the sensor.
Zero Reference Angle	The angle of pilot shaft rotation associated with the zero buoyancy condition in Interface or Density mode, or the zero differential buoyancy condition in Level mode. (The zero reference for the input of the PV calculation).
Driver Rod Length	The scale factor (moment arm) between a force input to the sensor driver rod and the torque developed as input to the torque tube.
Displacer Volume	The scale factor relating the density of the process fluid to the maximum force that can be produced as an input to the driver rod of the sensor.
SG	The density of the process fluid normalized to the density of water at reference conditions. The scale factor that transforms displacer volume and measured buoyancy into a level signal normalized to displacer length.
Displacer Length	The scale factor to convert normalized level to level on the displacer in engineering units.
Level Offset	The zero reference for the output of the PV calculation, referred to the location of the bottom of the displacer.
URV (Upper Range Value)	The value of computed process variable at which a 20 mA output (100% Range) is desired.
LRV (Lower Range Value)	The value of computed process variable at which a 4 mA output (0% Range) is desired.
D/A Trim	The gain and offset of the D/A converter which executes the digital commands to generate output
Instrument Temperature Offset	Bias to improve the accuracy of the ambient temperature measurement used to provide temperature compensation for the mechanical-to-electronic transducer.
Proc Temp Offset	Bias to improve the accuracy of the (RTD) temperature measurement used to provide compensation for process-temperature-related density changes.

These parameters are factory-set to the most common values for the 249 sensors. Therefore, for the bulk of units sold in simple level applications, it is possible to accept the defaults and run a Min/Max Calibration. If any of the advanced features of the instrument are to be used, accurate sensor and test fluid information should generally be entered before beginning the calibration.

## Primary

### Guided Calibration

Field Communicator	Configure > Calibration > Primary > Guided Calibration (2-5-1-1)
--------------------	--

Guided Calibration recommends an appropriate calibration procedures for use in the field or on the bench based on your input. Answer questions about your process scenario to reach the calibration recommendation. When feasible, the appropriate calibration method will be invoked from within the procedure.

## Full Calibration

Field Communicator	Configure > Calibration > Primary > Full Calibration (2-5-1-2)
--------------------	--

Full Calibration operations compute the sensor gain and zero reference from two independent observations of process data points. They are appropriate for cases where the two input conditions can be established relatively quickly in one session.

## Min/Max Calibration

The following procedure can be useful when process values can't be precisely observed, but the displacer can sequentially be submerged in fluids of known minimum and maximum density. (E.g., no sight glass is available, but the cage can be isolated and drained or flooded.)

Correct displacer information and the SG of the test fluid must be entered before performing this procedure. Capture Zero can be performed at minimum buoyancy (or completely submerged in upper fluid) before performing Min/Max Calibration.

Follow the prompts on the Field Communicator to calibrate the instrument and sensor.

1. Set the control loop for manual control.
2. Enter the specific gravity for the liquid in the system.
3. Adjust the liquid level until the displacer is dry (or completely submerged in upper liquid). Allow the output to settle, then acknowledge establishment of the minimum buoyancy condition to the system.
4. Adjust the liquid level until the displacer is completely submerged in the lower liquid. Allow the output to settle, then acknowledge establishment of the maximum buoyancy condition of the system.

The sensor is calibrated. Verify that the upper and lower range values are correct and return the loop to automatic control.

## Two Point Calibration

This procedure uses independent observations of two valid process conditions, together with the hardware dimensional data and SG information, to compute the effective torque rate and zero reference angle for the sensor. The two data points can be separated by any span between a minimum of 5% to 100%, as long as they remain on the displacer. Within this range, the calibration accuracy will generally increase as the data-point separation gets larger. Accuracy is also improved by running the procedure at process temperature, as the temperature effect on torque rate will be captured. (It is possible to use theoretical data to pre-compensate the measured torque rate for a target process condition when the calibration must be run at ambient conditions.)

An external method of measuring the process condition is required.

Follow the prompts on the Field Communicator to calibrate the sensor.

1. Put the control loop in manual control.
2. Adjust the process condition to a value near the top or bottom of the valid range.
3. Enter this externally measured process condition in the current PV units.
4. Adjust the process condition to a value near the bottom or top of the valid range, but at a position that is toward the opposite end of the range relative to the condition used in step 2.
5. Enter this second externally measured process condition in the current PV units.

The sensor is now calibrated. Be sure to verify that the upper and lower range values are correct before returning the loop to automatic control.

## Weight Calibration

This procedure may be used on the bench or with a calibration jig that is capable of applying a mechanical force to the driver rod to simulate displacer buoyancy changes. It allows the instrument and sensor to be calibrated using equivalent weights or force inputs instead of using the actual displacer buoyancy changes. If the displacer information has been entered prior to beginning the procedure, the instrument will be able to compute reasonable weight value suggestions for the calibration. However, the only preliminary data essential for the correct calibration of the torque rate is the length of the driver rod being used for the calibration.

Weight equivalent to the net displacer weight at two valid process conditions must be available. The sensor must have been sized properly for the expected service, so that the chosen process conditions are in the free-motion linear range of the sensor. The instrument should normally be physically coupled to the pilot shaft at what is going to be the zero buoyancy weight or the zero differential-buoyancy weight, depending on the calibration approach. (However, if the expected operational travel of the pilot is greater than 5 degrees, it is advisable to couple the transmitter to the pilot shaft at the condition representing mid-travel instead. This will prevent hitting a stop in the transmitter before limiting in the sensor.) A small zero trim correction may be necessary at start-up, since the weight input may not perfectly simulate the actual process fluid(s).

Follow the prompts on the Field Communicator to calibrate the sensor.

1. For interface level or density measurements, enter the specific gravity of the upper fluid and lower fluid as requested.
2. Place a weight on the displacer rod that is approximately equal to that indicated on the prompt. The suggested weight is equivalent to the effective displacer weight when the liquid is at its lowest level or the displacer is suspended in the liquid with the lower specific gravity.
3. After allowing the system to stabilize, enter the actual value of the weight suspended on the displacer rod.
4. Place a weight on the displacer rod that is approximately equal to that indicated on the prompt. The suggested weight is equivalent to the effective displacer weight when the liquid is at its highest level or the displacer is suspended in the liquid with the higher specific gravity.
5. After allowing the system to stabilize, enter the actual value of the weight suspended on the displacer rod.

The sensor is calibrated, but a small zero trim may be required when the actual process fluid(s) are introduced. Check the range values before putting the loop in service.

## Theoretical Calibration

In cases where it is not possible to manipulate the input at all, the user may set up a nominal calibration using information available about the hardware and the process. The theoretical torque rate for the installed torque tube may be looked up and compensated for process temperatures. This value is then manually entered in the instrument configuration. (The 'Change Torque Rate procedure under the *Manual Setup > Sensor > Torque Tube* menu can be used to look up and select theoretical values for common torque tubes if you select the 'Need Assistance' option instead of the 'Edit value directly' approach.) The displacer information and fluid SGs are entered. The desired range values are entered manually. Finally, Trim Zero computes PV to the current value of the process. It should be possible to control the loop with this rough calibration.

---

### Note

The theoretical torque rate for the installed torque tube is available in the Simulation of Process Conditions for Calibration of Fisher Level Controllers and Transmitters instruction manual supplement ([D103066X012](#)). Contact your [Emerson sales office](#) or Local Business Partner for information on obtaining this manual supplement.

---



Observations of the sight glass or other independent measurements may be logged against DLC3010 outputs over time. The ratio of the independent-observable process changes to the DLC3010 output changes may then be used as a scale factor to modify the theoretical torque rate stored in the instrument. After each gain adjustment, a new zero trim will be required. When a plant-maintenance shutdown occurs, the instrument may be isolated and calibrated in the normal manner.

## Partial Calibration

Field Communicator	Configure > Calibration > Primary > Partial Calibration (2-5-1-3)
--------------------	---

Partial Calibration operations are useful when it would take too long to establish a second data point in a single session. There are two types of partial calibrations: capture and trim. The 'capture zero' operation sets the input zero reference angle to the value currently being measured. It is therefore valid only at the defined zero process condition. Trim operations recompute either gain or zero reference angle with one observation of process data. The calibration parameter that is NOT being trimmed is assumed to be correct.

### Capture Zero

Capture Zero captures the current value of the torque tube angle as the input zero. The displacer must be loading the torque tube, and not resting on a travel stop. The torque tube must be coupled to the DLC3010 and the coupling access door must be closed. In Level mode, the captured angle represents zero differential buoyancy on displacer, and must be obtained at the actual process zero condition. In Interface and Density mode, the captured angle represents zero absolute buoyancy on displacer, and must be obtained at actual dry condition.

If the displacer is overweight and it is necessary to use the partial calibration methods, select Level mode and enter the differential density before using 'Capture Zero' and 'Trim Gain'. After the gain is correct, switch back to Density or Interface mode, (re-enter individual densities if Interface), then perform a 'Trim Zero' procedure to back-compute the required zero buoyancy angle.

The Capture zero procedure prompts you to verify the instrument is coupled to torque tube, coupling access door is closed, and verify that the displacer is completely dry.

---

#### Note

If the handle on the coupling access door is in the position towards the front of the transmitter, the coupling access hole is open and the lever is "locked" (pinned in the neutral travel position). In this condition, the true "at-rest" position of the linkage may not be captured correctly. Moving the handle to the rear of the transmitter closes the coupling-access hole and unlocks the lever.

---

It functions as the pre-calculation zero for the process measurement algorithm. This procedure can be run either before or after other calibration procedures. However, the procedure returns a valid result at only one input condition - zero buoyancy for Interface and zero differential buoyancy for Level mode.

Before calibration, use the *Configure > Manual Setup > Sensor* menu to verify that all sensor and compensation data match the calibration conditions.

### Trim Gain

Trim Gain operations recompute gain with one observation of process data.

Trim Gain trims the torque rate value to align the digital Primary Variable with the user's observation. This calibration assumes that sensor zero is already accurate and only a gain error exists. Actual process condition must be non-zero and able to be measured independently. Configuration data must contain density of calibration fluid(s), displacer volume, and driver rod length.

Before calibration, use the *Configure > Manual Setup > Sensor* menu to verify that all sensor and compensation data match the calibration conditions.

## Trim Zero

Trim Zero computes the value of the input angle required to align the digital Primary Variable with the user's observation of the process, and corrects the stored input zero reference, assuming that the calibration gain is accurate. Use this procedure when the process cannot be moved to zero for capture, but gain is known to be correct (only a bias error exists).

Before calibration, use the *Configure > Manual Setup > Sensor* menu to verify that all sensor and compensation data match the calibration conditions.

Follow the prompts on the Field Communicator.

1. Adjust the process condition or simulation to any valid and observable value.
2. Enter the external observation of the measurement in the current PV units.

## Secondary

### Temperature Calibration

Field Communicator	Configure > Calibration > Secondary > Temperature Calibration (2-5-2-1)
--------------------	---

This procedure allows you to display the temperature as measured by the instrument. You can then trim the temperature reading so that it matches the actual temperature more closely in the region of interest. (This is an offset adjustment only. There is no ability to change the gain.)

This calibration is initially performed at the factory. Performing it in the field requires an accurate independent measurement of the instrument housing temperature or process temperature, (as appropriate). The instrument should be at a steady-state condition with respect to that temperature when performing the procedure.

---

#### Note

The effectiveness of the instrument electronic temperature compensation depends upon the accuracy of the electronics temperature offset stored in the NVM (non-volatile memory). If the electronics temperature is incorrect, the temperature curve applied to the magnets and Hall sensor will be misaligned, resulting in over- or under-compensation.

---

### Trim Instrument Temperature

Follow the prompts on the Field Communicator to trim the instrument temperature.

### Trim Process Temperature

Trim Process Temperature is available if the Process Temperature Source is not Manual. Follow the prompts on the Field Communicator to trim the process temperature.

## Manual Entry of Process Temperature

Field Communicator	Configure > Manual Setup > Process Fluid > Process Temperature > Change Proc Temp (2-2-3-2-2)
--------------------	---

If a process temperature sensor (RTD) is not installed, it is possible to manually set the Digital Process Temperature variable to the target process temperature. This value will be used by any SG-compensation tables that the user has entered. If no compensation tables are active, the Digital Process Temperature value may be used to document the process temperature at which the instrument was calibrated, or the process temperature for which the stored torque rate is pre-compensated.

Follow the prompts on the Field Communicator to edit the Digital Proc Temp.

## Analog Output Calibration

### Scaled D/A Trim

Field Communicator	Configure > Calibration > Secondary > Analog Output Calibration > Scaled D/A Trim (2-5-2-2)
--------------------	---

This procedure allows trimming the gain and offset of the Digital-to-Analog (D/A) converter to adjust the accuracy at which the output follows 4 to 20 mA current commands from the firmware. This relationship is initially set in the factory, and should not require frequent user adjustment. Reasons for using this procedure include:

- Correction for component aging after the instrument has been in service for an extended period.
- Adjusting D/A calibration to be optimum at the normal operating temperature, when that temperature is considerably removed from room temperature conditions.

The procedure is iterative, and will eventually reach a resolution limit where attempts to improve the result will cycle at a few decimal places to either side of the target.

Follow the prompts on the Field Communicator to trim the D/A output.

1. Scale the output from 4 to 20 mA? If your reference meter is graduated in “mA”, select *Proceed* and go to step 5. If the reference reading is presented in some other unit system, such as “%” or “mm”, select *Change* and continue with step 2.
2. Enter the scale low output value.
3. Enter the scale high output value.
4. If the high and low output values are correct, select *Proceed* and continue to step 5. If they are not correct, select *Change* and return to step 2.
5. Connect a reference meter across the test connections in the terminal box. See the Test Connections procedure in the Installation section. You can also connect a reference meter in the loop as shown in figure 2-9.
6. The Field Communicator commands the instrument to set its output to 4 mA or the low output value.
7. Enter the reading from the reference meter.
8. If the reference meter reading equals 4 mA or the low output value, select *Yes* and continue to step 9. If not, select *No* and return to step 7.
9. The Field Communicator commands the instrument to set its output to 20 mA or the high output value.
10. Enter the reading from the reference meter.
11. If the reference meter reading equals 20 mA or the high output value, select *Yes* and continue to step 12. If not, select *No* and return to step 10.

12. The Field Communicator commands the instrument to set its output back to the original value.

---

**Note**

If communications with the device are lost before exit of the procedure, the device may be stuck in fixed output current mode. Be sure to check for the 'Analog Output Fixed' alert after communications are re-established, or disturb the input linkage and confirm output current change before returning the loop to Auto.

---

## Calibration Examples

### Calibration—with Standard Displacer and Torque Tube

Run the initial calibration near ambient temperature at design span to take full advantage of the available resolution. This is accomplished by using a test fluid with a specific gravity (SG) close to 1. The value of SG in the instrument memory during the calibration process should match the SG of the test fluid being used in the calibration. After the initial calibration, the instrument may be set up for a target fluid with a given specific gravity, or an interface application, by simple configuration data changes.

1. Run through Guided Setup and verify that all sensor data is correct.

**Procedure:**

Change the PV mode to Level

If your input observations are going to be made with respect to location of the bottom of the displacer at the lowest process condition, set the Level Offset value to 0.00, and

Set the Specific Gravity value to the SG of the test fluid being used.

Establish the test fluid level at the desired process zero point. Make sure that the DLC3010 lever assembly has been properly coupled to the torque tube (see coupling procedure on page 38). To unlock the lever assembly and allow it to freely follow the input, close the coupling access door on the instrument. It is often possible to watch the instrument display and/or the analog output to detect when the fluid hits the displacer, because the output will not start moving upward until that point is reached.

Select the Min/Max calibration from the Full Calibration menu, and confirm that you are at the 'Min' condition at the prompt. After the 'Min' point has been accepted, you will be prompted to establish the 'Max' condition. (The 'displacer completely covered' condition should be slightly higher than the 100% level mark to work correctly. For example, 15 inches above the zero mark would generally be enough for a 14 inch displacer on a 249B, because the amount of displacer rise expected for that configuration is about 0.6 inch.)

Accept this as the 'Max' condition. Adjust the test fluid level and check the instrument display and current output against external level at several points distributed across the span to verify the level calibration.

- a. To correct bias errors, 'Trim Zero' at a precisely known process condition.
- b. To correct gain errors, 'Trim Gain' at a precisely-known high level condition.

---

**Note**

If you are able to precisely observe individual input states, the Two-Point calibration may be used instead of Min/Max.

If for some reason you are unable to carry out Min/Max or Two Point Calibration, set the lowest process condition and Capture Zero. Run Trim Gain at a process level of minimum 5% above the Lower Range Value.

---

If the measured output doesn't come off the low saturation value until the level is considerably above the bottom of the displacer, it is possible that the displacer is overweight. An overweight displacer will rest on the lower travel stop until sufficient buoyancy has developed to allow the linkage to move. In that case, use the calibration procedure for overweight displacers found below.

After the initial calibration:

**For a level application**— Go to the Sensor Compensation menu and use the 'Enter constant SG' item to configure the instrument for the target process fluid density.

**For an interface application**— Change the PV mode to Interface, verify or adjust the range values presented by the Change PV mode procedure, and then use 'Enter constant SG' to configure the instrument for the SGs of each of the target process fluids.

**For a density application**— Change the PV mode to Density, and establish the desired range values in the 'Change PV mode' procedure.

If the target application temperature is considerably elevated or depressed from ambient, refer to pages 37 and 66 for information on temperature compensation.

---

**Note**

Information on computing precise simulation of this effect is available in the Simulation of Process Conditions for Calibration of Fisher Level Controllers and Transmitters instruction manual supplement ([D103066X012](#)), available from your Emerson sales office or Local Business Partner, or at [Fisher.com](http://Fisher.com).

---

## Calibration with an Overweight Displacer

When the sensor hardware is sized for greater mechanical gain (as it is in some interface or density measurement applications), the dry displacer weight is often greater than the maximum permissible load on the torque tube. In this situation it is impossible to 'capture' the zero buoyancy rotation of the torque tube, because the linkage is lying on a travel stop at that condition.

The 'Capture Zero' routine in the Partial Calibration menu group will therefore not function correctly in the target PV modes of Interface or Density when the displacer is overweight.

The Full Calibration routines: Min/Max, Two-Point, and Weight, will all work correctly at the actual process conditions when in interface or density mode, because they back-compute the theoretical zero-buoyancy angle instead of capturing it.

If it is necessary to use the Partial Calibration methods when the displacer is overweight, the following transformation may be used:

An interface or density application can be mathematically represented as a level application with a single fluid whose density is equal to the difference between the actual SGs of the fluid covering the displacer at the two process extremes.

The calibration process flows as follows:

- Change the PV mode to Level.
- Set the Level Offset to zero.
- Set the Range Values to:  
LRV = 0.0,  
URV = displacer length.
- Capture Zero at the lowest process condition (that is, with the displacer completely submerged in the fluid of the lowest density - NOT dry).
- Set Specific Gravity to the difference between the SGs of the two fluids (for example, if SG\_upper = 0.87 and SG\_lower = 1.0, enter a specific gravity value of 0.13).
- Set up a second process condition more than 5% of span above the minimum process condition, and use the Trim Gain procedure at that condition. The gain will now be initialized correctly. (The instrument would work fine in this configuration for an interface application. However, if you have a density application, it won't be possible to report the PV correctly in engineering units if the instrument calibration is concluded at this point.)

Since you now have a valid gain:

- Change the PV mode to Interface or Density,
- reconfigure the fluid SGs or range values to the actual fluid values or extremes, and
- use the Trim Zero procedure in the Partial Calibration menu to back-compute the theoretical zero-buoyancy angle.

The last step above will align the value of the PV in engineering units to the independent observation.

---

#### Note

Information on simulating process conditions is available in the Simulation of Process Conditions for Calibration of Fisher Level Controllers and Transmitters instruction manual supplement ([D103066X012](#)), available from your Emerson sales office or Local Business Partner, or at [Fisher.com](#).

---

Following are some guidelines on the use of the various sensor calibration methods when the application uses an overweight displacer:

**Weight-based:** Use two accurately known weights between minimum and maximum buoyancy conditions. The full displacer weight is invalid because it will put the linkage on a stop.

**Min/Max:** Min now means submerged in the lightest fluid and Max means submerged in the heaviest fluid.

**Two point:** Use any two interface levels that actually fall on the displacer. Accuracy is better if the levels are farther apart. The result should be close if you can move the level even 10%.

**Theoretical:** If the level cannot be changed at all, you can enter a theoretical value for torque tube rate manually, then Trim Zero to adjust the output to the current independent observation of the process condition. Gain and bias errors will exist with this approach, but it can provide nominal control capability. Keep records of subsequent observations of

actual process versus instrument output and different conditions and use the ratios between the process and instrument changes to scale the torque rate value. Repeat Zero Trim after each gain change.

## Density Applications - with Standard Displacer and Torque Tube

---

### Note

When you change 'PV is' from level or interface to density, the range values will be initialized to 0.1 and 1.0 SGU. You may edit the range values and density units after that initialization. The initialization is performed to clear out irrelevant numerical values from length dimensions that cannot be reasonably converted to density dimensions.

---

Any of the full sensor calibration methods (Min/Max, Two Point, and Weight) can be used in density mode.

**Min/Max:** The Min/Max Calibration first asks for the SG of your minimum density test fluid (which could be zero if the displacer is not overweight). Then, it has you set up a completely submerged displacer condition with that fluid. Next it asks for the SG of your maximum density test fluid and directs you to completely submerge the displacer in that fluid. If successful, the computed torque rate and zero reference angle are displayed for reference.

**Two Point:** The Two Point Calibration requires you to set up two different process conditions with as much difference as possible. You could use two standard fluids with well-known density and alternately submerge the displacer in one or the other. If you are going to try to simulate a fluid by using a certain amount of water, remember that the amount of displacer covered by the water is what counts, not the amount in the cage. The amount in the cage will always need to be slightly more because of the displacer motion. If successful, the computed torque rate and zero reference angle are displayed for reference.

**Weight Based:** The Weight Calibration asks you for the lowest and highest density you want to use for the calibration points, and computes weight values for you. If you can't come up with the exact values asked for, you are allowed to edit the values to tell it what weights you actually used. If successful, the computed torque rate and zero reference angle are displayed for reference.

## Sensor Calibration at Process Conditions (Hot Cut-Over) when input cannot be varied

If the input to the sensor cannot be varied for calibration, you can configure the instrument gain using theoretical information and use Trim Zero to trim the output to the current process condition. This allows you to make the controller operational and to control a level around a setpoint. You can then use comparisons of input changes to output changes over time to refine the gain estimate. A new trim zero will be required after each gain adjustment. This approach is not recommended for a safety-related application, where exact knowledge of the level is important to prevent an overflow or dry sump condition. However, it should be more than adequate for the average level-control application that can tolerate large excursions from a midspan set point.

There are a number of calibration methods available in the DLC3010 Device Description. Two Point Calibration allows you to calibrate the torque tube using two input conditions that put the measured interface anywhere on the displacer. The accuracy of the method increases as the two points are moved farther apart, but if the level can be adjusted up or down a minimum 5% span, it is enough to make a calculation. Most level processes can accept a small, manual adjustment of this nature. If your process cannot, then the theoretical approach is the only method available.

1. Determine all the information you can about the 249 hardware: 249 type, mounting sense (controller to the right or left of displacer), torque tube material and wall thickness, displacer volume, weight, length, and driver rod length. (the driver rod length is not the suspension rod length, but the horizontal distance between the centerline of the displacer and the centerline of the torque tube). Also obtain process information: fluid densities, process temperature, and pressure. (The pressure is used as a reminder to consider the density of an upper vapor phase, which can become significant at higher pressures.)

2. Run Instrument Setup and enter the various data that is requested as accurately as possible In Manual Setup. Set the *Range Values* (LRV, URV) to the PV values where you will want to see 4 mA and 20 mA output, respectively. These might be 0 and 14 inches on a 14 inch displacer.
3. Mount and couple at the current process condition. Do not run the Capture Zero procedure, because it will not be accurate.
4. With the torque tube type and material information, find a theoretical value for the composite or effective torque-tube rate. (Refer to the Entering Theoretical Torque Tube (TT) Rates procedure in this section), and enter it in the instrument memory. The value can be accessed by selecting:  
*Configure > Manual Setup > Sensor > Torque Tube > Change Torque Rate (2-2-1-3-2)*  
If you select the 'Need Assistance' option instead of the 'Edit value directly' approach, the procedure can look up values for commonly available torque tubes.
5. If the process temperature departs significantly from room temperature, use a correction factor interpolated from tables of theoretical normalized modulus of rigidity. Multiply the theoretical rate by the correction factor before entering the data. You should now have the gain correct to within perhaps 10%, at least for the standard wall, short length torque tubes. (For the longer torque tubes (249K, L, N) with thin-wall and a heat insulator extension, the theoretical values are much less accurate, as the mechanical path departs considerably from the linear theory.)

---

**Note**

Tables containing information on temperature effects on torque tubes can be found in the Simulation of Process Conditions for Calibration of Fisher Level Controllers and Transmitters instruction manual supplement ([D103066X012](#)), available from your Emerson sales office or Local Business Partner, or at [Fisher.com](#). This document is also available in the device help files linked to some host applications with graphical user interfaces.

---

6. Using a sight glass or sampling ports, obtain an estimate of the current process condition. Run the Trim Zero calibration and report the value of the actual process in the PV engineering units.
7. You should now be able to go to automatic control. If observations over time show the instrument output exhibits, for example, 1.2 times as much excursion as the sight glass input, you could divide the stored torque tube rate by 1.2 and send the new value to the instrument. Then run another Trim Zero calibration and observe results for another extended period to see if further iteration is required.

## Entering Theoretical Torque Tube (TT) Rates

The Simulation of Process Conditions for Calibration of Fisher Level Controllers and Transmitters instruction manual supplement (D103066X012) provides the theoretical composite torque tube (TT) rate for 249 sensors with DLC3010 controllers. These numbers are nominal values. They should be within 10% of the values that the instrument would compute when you perform a sensor calibration. They will be less accurate for the long torque tubes (249K, L, N, VS, and P), especially with thin-wall constructions.

If you are unable to perform a sensor calibration during installation, you may enter the values into the instrument at the following menu item in the handheld:

*Configure > Manual Setup > Sensor > Torque Tube > Change Torque Rate (2-2-1-3-2)*

If you select the 'Need Assistance' option instead of the 'Edit value directly' approach, the procedure can look up values for commonly available torque tubes.

Then, manually set the LRV and URV to the PV values at which you desire 4 and 20 mA output, respectively:

*Configure > Manual Setup > Variables > Primary Variable Range > Upper or Lower Range Value (2-2-2-3-1 or -2)*

Next, perform a *Trim Zero* operation to align the instrument output with the sight glass reading:

*Configure > Calibration > Primary > Partial Calibration > Trim Zero (2-5-1-3-3)*

These steps will provide an approximate PV calibration to get a system operational. Further refinements can then be made when it is possible to manipulate and observe the level and instrument output.



## Excessive Mechanical Gain

If the displacer/torque tube sizing provides more than 4.4 degrees of torque tube rotation for a full span change in process input, it may be difficult to obtain a valid calibration with the normal coupling procedure. In such a case, you can utilize the full mechanical span of the DLC3010 by coupling the instrument to the torque tube at the 50% travel condition, instead of at the lowest process condition. When coupled at the 50% travel condition, the travel limits of the 249 hardware will be the constraining factor. If the 249 travel limit is reached before full process input travel is achieved, the hardware is either improperly sized for the application, improperly assembled, or damaged.

## Determining the SG of an Unknown Fluid

If the instrument has been calibrated with weights or by using a test fluid with a well-known SG, it is possible to use the instrument to measure the SG of an unknown fluid, or the differential SG between two fluids. A procedure called 'Measure Density' is provided in the Manual Setup - Process Fluid menu when you are in Level measurement mode. The procedure presents the measured value and allows you either to automatically move it into the instrument configuration, or to manually record it for later use.

## Accuracy Considerations

### Effect of Proportional Band

If you are operating at low Proportional Band [ $PB = 100\% \text{ times (full span torque tube rotation) / (4.4 degrees)}$ ], you can expect a degradation factor of about  $(100\%)/(PB\%)$  on the Transmitter accuracy specifications.

---

#### Note

This formula is most correct for linearity errors that are relatively steep-sided. If the linearity error curve shape is simple with relatively gradual slope, the net effect of reducing span may be less. Instruments such as the DLC3010, that use a compensation technique to reduce the residual mechanical or electrical non-linearity, will generally have a complex shape for the net-error curve.

---

If this is too much degradation, an improvement of 2.0 can be obtained by using a thin-wall torque tube. Additional gain can be achieved by increasing the displacer diameter. Available clearance inside the cage, and the need to keep the net displacer weight at the highest and lowest process conditions within the usable range of the torque tube / driver rod combination, place practical limits on how much the sizing can be adjusted.

With an overweight displacer, the calibration process becomes more difficult, (because the zero buoyancy condition will occur with the linkage driven hard into a travel stop). In interface measurement mode it becomes impossible to Capture Zero. One simple and effective solution is to use Level measurement mode. Capture Zero at the lowest process condition instead of zero buoyancy, and enter the differential  $SG = (SG_{\text{lowerfluid}} - SG_{\text{upperfluid}})$ . The algorithm then computes level correctly.

## Density Variations in Interface Applications

A high sensitivity to errors in the knowledge of fluid density can develop in some interface applications. For example: Suppose the whole input span is represented by an effective change in SG of 0.18. Then a change in the actual SG of the upper fluid from 0.8 to 0.81 could cause a measurement error of 5.6% of span at the lowest interface level. The sensitivity to the knowledge of a fluid density is maximum at the process condition where that fluid covers all of the displacer, zero at the opposite extreme process condition, and varies linearly between those points.

If the fluid density changes are batch-related or very gradual, it may be practical to keep track of the SG of the fluid and periodically reconfigure the transmitter memory to match the actual process condition. Frequent automatic updates to this variable are not advised, as the NVM location where it is stored has an expected lifetime of about 10,000 write operations. If changes are only a function of temperature, the characteristic of the fluid can be loaded once in the NVM table, and an RTD connected to measure the process temperature and drive the correction table. If temperature is not the driving influence, the best that can be done is to calibrate for the widest potential differential SG. (This will keep the variations as small a percentage of calibrated span as possible.) Then calculate an alarm threshold that will prevent vessel over- or under-flow at the worst case error.

## Extreme Process Temperatures

For applications that will run at extreme temperatures, the effect of process temperature on the torque tube must be taken into account. Best results are obtained by running the torque tube calibration at actual process temperature. However, the decrease in spring rate with temperature can be simulated at room temperature by increasing the load on the torque tube during room-temperature calibration. This will produce the same deflection that would occur at actual process conditions. This compensation is theoretical and not perfect, but is still an improvement over ambient calibration with no attempt at compensation.

---

### Note

For additional information, refer to the Simulation of Process Conditions for Calibration of Fisher Level Controllers and Transmitters instruction manual supplement ([D103066X012](#)), available from your Emerson sales office or Local Business Partner, or at [Fisher.com](#).

---

## Temperature Compensation

If the process temperature departs significantly from calibration temperature, you will need to apply a correction factor. Interpolate the correction factor from the material-specific tables of theoretical normalized modulus of rigidity versus temperature, as described in the Simulation of Process Conditions for Calibration of Fisher Level Controllers and Transmitters instruction manual supplement. Multiply the measured torque tube rate (editable in the review menu under factory settings) by the correction factor and enter the new value. When you cannot calibrate at process temperature this approach allows a better approximation of the actual torque tube behavior at process conditions.

## Section 5 Service Tools

### Active Alerts

Field Communicator	Service Tools > Active Alerts (3-1)
--------------------	-------------------------------------

#### Visible if an alert is not active

No Active Alerts

#### Visible if an alert is active

Refresh Alerts— issues a request to the device to update the reported status information for display. This is used to clear displayed alerts after corrective action has been taken. Items in the following list appear only if the associated alert is active:

- **F: Process Temperature Signal Failed** - When active, indicates the process temperature sensor (RTD) reading has exceeded the hardcoded limits (<10 ohms or >320 ohms).  
If this status message appears, appears:
  1. Check condition of RTD and its wiring. Ensure RTD is connected.
  2. For temporary remedial action, switch 'Process Temperature Source' to 'Manual Entry' and enter best estimate of current process temperature.
  3. After repair of RTD circuit, restore.
- **F: Sensor Drive Failed** - The Hall sensor drive current read-back is outside of the hard-coded limits.  
If this message appears:
  1. Confirm integrity of connection between electronics module and transducer board.
  2. If Hall sensor continuity is good, replace electronics module.
  3. If not, replace instrument. (Check warranty status.)
- **F: Sensor Signal Failed** - The instrumentation amplifier output for the torque tube position is outside of range.  
If this message appears:
  1. Check whether instrument lever assembly is being driven to a mechanical stop by the sensor linkage.
  2. If so, correct the coupling configuration.
  3. Otherwise, replace instrument or electronics module as appropriate.
- **M: Non-Primary Variable Out of Limits** - When active, indicates the process applied to a sensor, other than that of the Primary Variable, is beyond the operating limits of the device. This indicates Electronics or Process Temperature has reached or exceeded the associated temperature alert limits. This is a summary alert - check the appropriate detail alerts for recommendations.
- **M: Analog Output Saturated** - The Analog Output value reported by the instrument is beyond the limits (3.8 or 20.5 mA) and no longer represent the true applied process.  
If this message appears:
  1. Check whether the PV range values (and Level Offset, where applicable) are set appropriately.
  2. Confirm that PV is tracking physical process - check calibration.
  3. If temperature compensation is being used on fluid density parameters, check the process temperature signal quality (or manual value), and the compensation table accuracy.
  4. Confirm that the hardware and data configurations are correct for the application.
  5. Check mechanical hardware for damage.

- **M: Processor Free Time Depleted** - There is insufficient free time remaining in the execution period to complete the scheduled tasks.  
If this message appears:
  1. Reset the processor or cycle power to the instrument.
  2. If the condition repeats, replace the electronics module. (Check warranty status.)
- **M: NVM Write Limit Exceeded** - When active, indicates the total number of writes to one of the three areas of NVM has exceeded the hardcoded limit. Try cycling power to the instrument and see if it clears.  
If it does not clear:
  1. If the Configuration NVM count is 0, replace the electronics module. Check for system conditions that could cause frequent automatic writes to configuration data.
  2. If the Transducer NVM count is 0, the most likely cause is a circuit failure on the transducer board. Replace and submit the instrument for warranty consideration.

---

**Note**

The Buffer NVM is only used during firmware load. It should never deplete its remaining write count.

---

- **A: Analog Output Fixed** - The Analog Output is in Fixed Current Mode.  
If this message appears:
  1. If the device is in multi-drop mode (Polling Address is non-zero) or a loop test is in progress, this is an intended state.
  2. If point-to-point network topology is desired, restore polling address to zero
  3. If device was accidentally left in loop test, exit fixed current mode.
- **A: Cold Start** - A power cycle or device reset has occurred.  
If this message appears:
  1. If event was unexpected, check condition of loop wiring and power supply.
  2. Check the terminal box integrity and instrument function over the range of environmental conditions being experienced.
- **A: Instrument Temperature Too Low** - When active, indicates that the Instrument Temperature has exceeded the value of the Instrument Temperature Low Alert Threshold.
- **A: Instrument Temperature Too High** - When active, indicates that the Instrument Temperature has exceeded the value of the Instrument Temperature High Alert Threshold.

If instrument temperature alert messages appear:

1. Check accuracy of temperature signal.
  2. Modify mounting/installation of device to maintain the operating temperature within limits.
  3. Check functionality. If degraded, replace the device.
  4. Check for appropriate value of Alert Threshold.
- **A: Process Temperature Too Low** - When active, indicates that the Process Temperature has exceeded the value of the Process Temperature Low Alert Threshold.
  - **A: Process Temperature Too High** - When active, indicates that the Process Temperature has exceeded the value of the Process Temperature High Alert Threshold.

If process temperature alert messages appear:

1. Check accuracy of temperature signal.
2. Adjust process temperature within limits.
3. Inspect sensor hardware for any damage caused by temperature extremes. Repair or replace components as required.
4. Check for appropriate value of Alert Threshold.

- **A: PV LoLo Alert** - When active, indicates that the Process Variable has exceeded the value of the Process Variable Low Low Alert Threshold. Analog Output set to jumper-selected alarm current, (if in Point-to-Point network).
  1. Take immediate action to stop violation of process limits.
  2. Take remedial action for any process stream quality or drain contamination incurred.
  3. Check calibration of instrument.
  4. Check for appropriate value of Alert Threshold.
- **A: PV Lo Alert** - When active, indicates that the Process Variable has exceeded the value of the Process Variable Low Alert Threshold.  
 If this message appears:
  1. Correct the out-of-limits process condition.
  2. Check calibration of instrument.
  3. Check for appropriate value of Alert Threshold.
- **A: PV HiHi Alert** - When active, indicates that the Process Variable has exceeded the value of the Process Variable High High Alert Threshold. Analog Output set to jumper-selected alarm current (if in Point-to-Point network).
  1. Take immediate action to stop violation of process limits.
  2. Take remedial action for any process stream quality or overflow incurred.
  3. Check calibration of instrument.
  4. Check for appropriate value of Alert Threshold.
- **A: PV Hi Alert** - When active, indicates that the Process Variable has exceeded the value of the Process Variable High Alert Threshold.  
 If this message appears:
  1. Correct the out-of-limits process condition.
  2. Check calibration of instrument.
  3. Check for appropriate value of Alert Threshold.
- **A: PV Out of Limits** - Primary Variable value is beyond its operating limit.

## Variables

Field Communicator	Service Tools > Variables (3-2)
--------------------	---------------------------------

Follow the prompts on the Field Communicator display to view the following analog output variables.

**PV is**— Indicates the type of measurement either level, interface (the interface of two liquids of different specific gravities), or density (measures the liquid specific gravity). The process variable displayed and measured depends on the entry for “PV is” under PV Setup.

### Primary Variable

- **PV Value**— Indicates the current process variable (level, interface, or density) in engineering units.
- **% Range**— Indicates the current process variable in percent of the span determined by the lower range value and the upper range value.

Refer to figure 5-1. If the digital level controller is setup for direct action the lower range value is less than the upper range value. If the digital level controller is setup for reverse action the lower range value is greater than the upper range value. Use the following equation to calculate the % range values:

$$PV(\%range) = \frac{(PV_{EU} - LRV)}{(URV - LRV)} \times 100$$

where:

$PV_{EU}$  = process variable in engineering units

The LRV always represents the 0% range value and the URV always represents the 100% range value.

Figure 5-1. PV % Range Indication for Direct and Reverse Action with a 32-Inch Displacer Ranged for 8 to 24 Inches

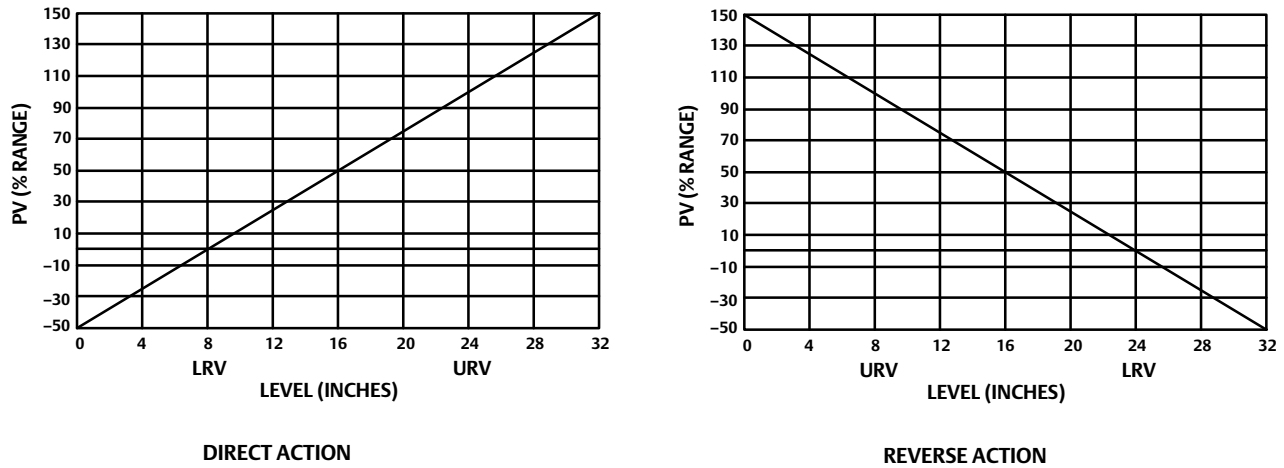

E0383

AO— Indicates the current analog output value of the instrument, in milliamperes.

Inst Temp— Indicates the current Instrument Temperature.

#### Process Temperature

- Proc Temp Source— The source of measurement for Process Temperature.
- Proc Temp— Indicates the current Process Temperature.

Torque Rate— Torque rate of the torque tube applied in PV measurements.

Upper Fluid Density — Density of Upper Fluid applied in PV measurements.

---

#### Note

Upper Fluid Density is only visible if PV is Interface

---

Lower Fluid Density— Density of Lower Fluid applied in PV measurements.

---

#### Note

Lower Fluid Density is only visible if PV is Level or Interface

---

## Maintenance

### Tests

Field Communicator	Service Tools > Maintenance > Tests (3-3-1-1)
--------------------	---

**LCD Test**— only visible if LCD Configuration is installed

The meter activates all segments immediately after power-up, during a digital level controller self-test, or during a master reset sent by a host supporting HART communications. You can also test the meter by selecting *Turn Cells On* to turn on all display segments, including the analog output bar graph, or select *Turn Cells Off* to turn off all display segments. When finished with the test, press OK to return the meter to normal display mode.

**Loop Test**— used to verify the controller output, the integrity of the loop, and the operations of any recorders or similar devices installed in the loop. To initiate a loop test, perform the following procedure:

1. Connect a reference meter to the controller. To do so, either connect the meter to the test connections inside the terminal box (see the Test Connections procedure) or connect the meter in the loop as shown in figure 2-9.
2. Access *Loop Test*.
3. Select *OK* after you set the control loop to manual.

The Field Communicator displays the loop test menu.

4. Select a discreet milliamp level for the controller to output. At the “Choose analog output” prompt, select *4 mA*, *20 mA*, or *Other* to manually input a value between 4 and 20 milliamps.
5. Check the reference meter to verify that it reads the value you commanded the controller to output. If the readings do not match, either the controller requires an output trim, or the meter is malfunctioning.

After completing the test procedure, the display returns to the loop test screen and allows you to choose another output value or end the test.

### Reset/Restore

Field Communicator	Service Tools > Maintenance > Reset/Restore (3-3-2)
--------------------	---

Restore Factory Defaults

- **Restore Factory Configuration**— Follow the prompts on the Field Communicator display to restore the digital level controller to the factory configuration.
- **Restore Factory Compensation**— Replaces all calibration and compensation data with factory defaults.

Both Restore Factory Configuration and Restore Factory are drastic procedures which should be used only as a last resort.

**Reset Device**— Issues a master reset request to the processor in the DLC3010.





## Section 6 Maintenance & Troubleshooting

The DLC3010 digital level controller features a modular design for easy maintenance. If you suspect a malfunction, check for an external cause before performing the diagnostics described in this section.

Sensor parts are subject to normal wear and must be inspected and replaced as necessary. For sensor maintenance information, refer to the appropriate sensor instruction manual.

### **⚠ WARNING**

**To avoid personal injury, always wear protective gloves, clothing, and eyewear when performing any maintenance operations.**

**Personal injury or property damage due to sudden release of pressure, contact with hazardous fluid, fire, or explosion can be caused by puncturing, heating, or repairing a displacer that is retaining process pressure or fluid. This danger may not be readily apparent when disassembling the sensor or removing the displacer. Before disassembling the sensor or removing the displacer, observe the appropriate warnings provided in the sensor instruction manual.**

**Check with your process or safety engineer for any additional measures that must be taken to protect against process media.**

### **CAUTION**

**When replacing components, use only components specified by the factory. Always use proper component replacement techniques, as presented in this manual. Improper techniques or component selection may invalidate the approvals and the product specifications, as indicated in table 1-1. It may also impair operations and the intended function of the device.**

## Diagnostic Messages

In addition to the output, the LCD meter displays abbreviated diagnostic messages for troubleshooting the digital level controller. To accommodate two-word messages, the display alternates between the first and second word. The meter displays messages simultaneously on the Process Variable and Process Variable Unit lines as shown in figure 6-1. Messages on the Process Variable line refer to general device conditions, while messages on the Process Variable Unit line refer to specific causes for these conditions. A description of each diagnostic message follows.

- **[BLANK]**— If the meter does not appear to function, and the instrument is otherwise functioning correctly, make sure the digital level controller is configured for the LCD meter. The meter will not function if the *LCD Configuration* selection is “Not Installed.” To check this function, connect the Field Communicator to the digital level controller and turn it on. From the Online menu, select:  
*Configure > Manual Setup > Instrument Display > LCD Configuration (2-2-5-1)*  
For information on setting up the LCD meter see page 47. A diagnostic test for meter function is also detailed later in this section.

Figure 6-1. LCD Meter Diagnostic Display

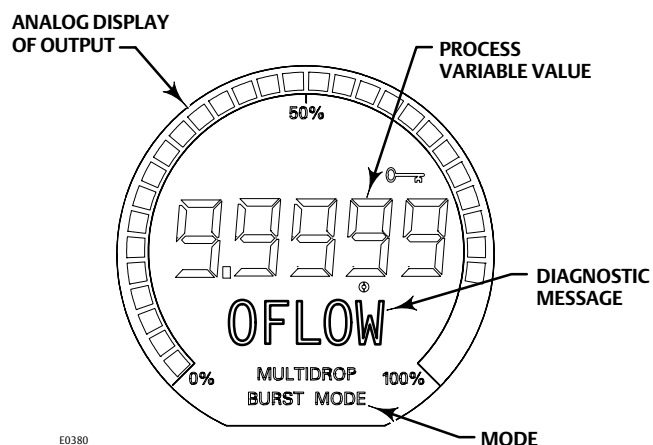

- **FAIL HDWR**— This message indicates the existence of one or more of the following conditions:

- The primary sensor input conversion is out of range.
- The primary sensor drive current is out of range.
- The internal reference voltage for controlling the loop current is out of range.

Perform the diagnostic procedures detailed later in this section to isolate the specific failure. If diagnostics indicate a failure of a particular module, replace the indicated module with a new one. Otherwise, correct the mechanical input condition to clear the message.

- **OFLOW**— The location of the decimal point, as configured in the meter setup, is not compatible with the value to be displayed by the meter. For example, if the meter is measuring a level greater than 99.999 mm, and the meter decimal point is set to 3 digit precision, the meter will display an “OFLOW” message because it is only capable of displaying a maximum value of 99.999 when set to 3 digit precision. The position of the decimal point may be adjusted by using the Field Communicator. From the Online menu, select: *Configure > Manual Setup > Instrument Display > Decimal Places (2-2-5-4)*. Selecting “0” will put the display in auto-scale mode. (The number of decimal places displayed will be the maximum remaining in the display field for the current value of PV.)

## Hardware Diagnostics

If you suspect a malfunction despite the absence of diagnostic messages on the Field Communicator display, follow the procedures described in table 6-1 to verify that the digital level controller hardware and process connections are in good working order. Under each of the major symptoms, specific suggestions are offered for solving problems. Always deal with the most likely and easiest-to-check conditions first.

Table 6-1. Troubleshooting

Symptom	Potential Source	Corrective Action
Analog Output is within valid range but Instrument does not communicate with Field Communicator	Loop Wiring	1. Check resistance between the power supply and the Field Communicator connection. The net resistance in the loop must be between 230 and 1100 Ohms for HART communication. 2. Check for adequate voltage to the digital level controller. Refer to figure 2-10 for requirements. Some models of battery-operated field calibrators do not have sufficient compliance voltage to operate a DLC3010 over the entire output current range. 3. Check for excessive capacitance in the field wiring. (Isolate the instrument from field wiring and try to communicate locally.)
	Terminal Box	4. If the terminal box does not have a 4-digit date-code sticker inside the lower lip, it may have developed a high internal resistance. Try a new terminal box.
	Electronics Module	5. Swap the electronics module with a known good part.
	Transducer Module	6. If the electronics module and terminal box work on a known good transducer module, replace the old transducer module.
Output $\approx$ 0 mA	Loop Wiring	7. Check for open circuits. 8. Check for proper polarity at the signal terminals. — See item 2. above.
	Terminal Box	9. Check resistance between “Loop+” and “T” terminals of terminal box. If greater than 1.1 Ohm, the internal sense resistor may be damaged. An external jumper may be added for a temporary repair. Replace terminal box and avoid applying loop voltage across “T” and “Loop+” for long term solution. — See item 4. above
	Electronics Module	— See item 5. above.
	Transducer Module	— See item 6. above.
Fixed Output $\approx$ 3.7 mA	Alarm Condition (Fail-low setting)	Connect the Field Communicator and: 10. Select <i>LCD Test</i> (3-3-1-1) to isolate a module failure. 11. Check PV against Hi-Hi and Lo-Lo alarm thresholds and PV alarm deadband setting, if these alarms are enabled.
Fixed Output = 3.8 mA	Low Saturation	Connect the Field Communicator and: 12. Check the PV against the upper and lower range values. Check actual process condition and calibration adjustments.
Fixed Output = 20.5 mA	High Saturation	Connect the Field Communicator and: — see item 12. above.
Fixed Output $\approx$ 22.5 mA	Alarm Condition (Fail-high setting)	Connect the Field Communicator and: — see items 10. and 11. above.
Fixed Output > 22.5 mA	Loop Wiring	13. Check for short circuits.
	Terminal Box	14. Remove terminal box from the instrument, and apply 24 Volts between Loop+ and Loop- terminals, (with a series resistance of approximately 1200 Ohms to protect power supply). If any current flows, replace terminal box.
	Electronics Module	— See item 5. above.
Output is within 4-20 mA range, but does not track displayed PV value (e.g., a) gain error, b) low saturation occurs at a value higher than 3.8 mA, c) high saturation occurs at a value lower than 20.5 mA)	Electronics Module	Connect the Field Communicator and: 15. Run Loop diagnostic test (3-3-1-1) [(3-3-1-2) if LCD Configuration is installed]. If the forced output does not track commands, attempt <i>Scaled D/A Trim</i> procedure (2-5-2-2-1). If D/A calibration cannot be restored, replace Electronics Module.
Output Drifting while at fixed process input.	Sensor	16. Check torque tube spring rate change versus process temperature per figure 1-2. Use appropriate material for process temperature. Pre-compensate the calibration for target process condition.
	Transducer Module	Connect the Field Communicator and: 17. Check <i>Instrument Temperature</i> (3-2-4) against an independent measurement of DLC3010 temperature. a) If inaccurate, trim the instrument temperature measurement (2-5-2-1-1) to improve ambient temperature compensation performance. b) If <i>Instrument Temperature</i> value is extreme, replace transducer module.
	Electronics Module	Connect the Field Communicator and: 18. Run Loop diagnostic test (3-3-1-1) [(3-3-1-2) if LCD Configuration is installed]. Leave instrument in fixed current mode at 12 mA command and observe analog output variation with ambient temperature. If drift exceeds specifications replace electronics module.
	Configuration Data	Connect the Field Communicator and: 19. Check stored <i>Specific Gravity</i> values (2-2-3-1) against independent measurement of process density. If process SG has changed from calibration values, correct configuration data to match process
Erratic Output	Loop Wiring	If output current enters a limit cycle between zero and a value within the 4-20 mA range when level reaches some arbitrary upper threshold, 20. Check for excessive loop resistance or low compliance voltage. (See items 2. and 4. above.)
Scrambled or erratic Display on LCD	Loop Wiring	—see item 20. above. (Insufficient voltage to operate display)
	LCD Assy	21. Swap LCD Assy with known good part.
	Electronics Module	22. Connector solder joint failure in electronics module. Replace module.

## Test Terminals

Test connections inside the terminal box can be used to measure loop current. These terminals are across an internal 1 ohm resistor that is in series with the loop.

1. Remove the terminal box cap.
2. Adjust the test meter to measure a range of 0.001 to 0.1 volts.
3. Connect the positive lead of the test meter to the + connection and the negative lead to the T connection inside the terminal box.
4. Measure Loop current as:

Voltage (on test meter)  $\times$  1000 = milliamps

example:

Test meter Voltage  $\times$  1000 = Loop Milliamps

0.004  $\times$  1000 = 4.0 milliamperes

0.020  $\times$  1000 = 20.0 milliamperes

5. Remove test leads and replace the terminal box cover.

## Removing the Digital Level Controller from the Sensor

Because of its modular design, most of the service and maintenance to the digital level controller can be done without removing it from the sensor. However, if necessary to replace sensor to instrument mating parts or parts in the transducer housing, or to perform bench maintenance, perform the following procedures to remove the digital level controller from the sensor.

### **⚠ WARNING**

**On an explosion-proof instrument, remove the electrical power before removing the instrument covers in a hazardous area. Personal injury or property damage may result from fire and explosion if power is applied to the instrument with the covers removed.**

---

## Tools Required

Table 6-2 lists the tools required for maintaining the DLC3010 digital level controller.

Table 6-2. Tools Required

Tool	Size	Usage	Keys
Hex Key	2 mm	Handle Cover-lock set screws	31 20
Hex Key	2.5 mm	Small cap screws	13
Hex Key	4 mm	Lever assembly mtg cap screw	14
Hex Key	5 mm	Terminal box mtg cap screw	7
Hex Socket	10 mm	Coupling nut	76
Open-end	13 mm	Transmitter mounting nuts	34
Phillips Screwdriver		Terminal screws Electronics module mtg screws	25 36
Small flat blade screwdriver		LCD assy mtg screws	40
Strap wrench		Helpful for removing a display cover that has been over-tightened	3
Large flat blade screwdriver <sup>(1)</sup>		Flex circuit mtg screws	19
Needle nose pliers <sup>(1)</sup>		Align/clamp ring extraction	17

1. Needed to remove a flex circuit if date code numbers are requested for warranty information.

## Removing the DLC3010 Digital Level Controller from a 249 Sensor

### 249 Sensor in Standard Temperature Applications

1. Loosen the set screw (key 31) in the terminal box cover assembly (key 6) so that the cover can be unscrewed from the terminal box.
2. After removing the cover (key 6), note the location of field wiring connections and disconnect the field wiring from the wiring terminals.
3. As shown in figure 2-4, locate the access handle on the bottom of the transducer housing. Using a 2 mm hex key, back out the set screw in the depression on the access handle until it is flush with the handle surface. Press on the back of the handle, as shown in the figure, and slide the handle toward the front of the unit, (the locked position), to expose the access hole. Be sure the locking handle drops into the detent.

#### Note

If the access handle will not slide, the sensor linkage is most likely in an extreme position. When the lever assembly is at a hard stop inside the housing, the locking pin on the access door may not be able to engage the mating slot in the lever assembly. This condition can occur if the displacer has been removed, if the sensor is lying on its side, or if the instrument had been coupled to the sensor while the displacer was not connected. To correct this condition, manipulate the sensor linkage to bring the lever assembly to within approximately 4 degrees of the neutral position before attempting to slide the handle. A probe inserted through the top vent of the 249 head may be required to deflect the driver rod to a position where the lever assembly is free.

4. Using a 10 mm deep well socket inserted through the access hole, loosen the shaft clamp (figure 2-4).
5. Loosen and remove the hex nuts (key 34) from the mounting studs (key 33).
6. Carefully pull the digital level controller straight off the sensor torque tube.

### CAUTION

Tilting the instrument when pulling it off of the sensor torque tube can cause the torque tube shaft to bend. To prevent damage to the torque tube shaft, ensure that the digital level controller is level when pulling it off of the sensor torque tube.

7. When re-installing the digital level controller, follow the appropriate procedure outlined in the Installation section. Also setup the digital level controller as described in the Initial Setup section.

## 249 Sensor in High Temperature Applications

1. Loosen the set screw (key 31) in the terminal box cover assembly (key 6) so that the cover can be unscrewed from the terminal box.
2. After removing the cover (key 6), note the location of field wiring connections and disconnect the field wiring from the wiring terminals.
3. As shown in figure 2-4, locate the access handle on the bottom of the transducer housing. Using a 2 mm hex key, back out the set screw in the depression on the access handle until it is flush with the handle surface. Press on the back of the handle, as shown in the figure, and slide the handle toward the front of the unit, (the locked position), to expose the access hole. Be sure the locking handle drops into the detent.

---

### Note

If the access handle will not slide, the sensor linkage is most likely in an extreme position. When the lever assembly is at a hard stop inside the housing, the locking pin on the access door may not be able to engage the mating slot in the lever assembly. This condition can occur if the displacer has been removed, if the sensor is lying on its side, or if the instrument had been coupled to the sensor while the displacer was not connected. To correct this condition, manipulate the sensor linkage to bring the lever assembly to within approximately 4 degrees of the neutral position before attempting to slide the handle. A probe inserted through the top vent of the 249 head may be required to deflect the driver rod to a position where the lever assembly is free.

---

4. Using a 10 mm deep well socket inserted through the access hole, loosen the shaft clamp (figure 2-4).
5. While supporting the instrument, loosen and remove the cap screws (key 63).
6. Carefully pull the digital level controller straight off the torque tube shaft extension (key 58).

## CAUTION

**Tilting the instrument when pulling it off of the sensor torque tube can cause the torque tube shaft to bend. To prevent damage to the torque tube shaft, ensure that the digital level controller is level when pulling it off of the sensor torque tube.**

---

7. Loosen and remove the hex nuts (key 34) from the mounting studs (key 33).
8. Pull the heat insulator (key 57) off the mounting studs.
9. When re-installing the digital level controller, follow the appropriate procedure outlined in the Installation section. Also setup the digital level controller as described in the Setup and Calibration section.

## LCD Meter Assembly

### ⚠ WARNING

**In an explosion-proof or flame-proof installation remove the electrical power before removing the instrument covers in a hazardous area. Personal injury or property damage may result from fire and explosion if power is applied to the instrument with the covers removed.**

---

The digital level controller is designed with a dual-compartment housing; one compartment contains the LCD meter and Electronics Module; the other contains all wiring terminals and the communication receptacles. The LCD meter is located in the compartment opposite the wiring terminals, as shown in figure 6-2.

Figure 6-2. DLC3010 Digital Level Controller Assembly

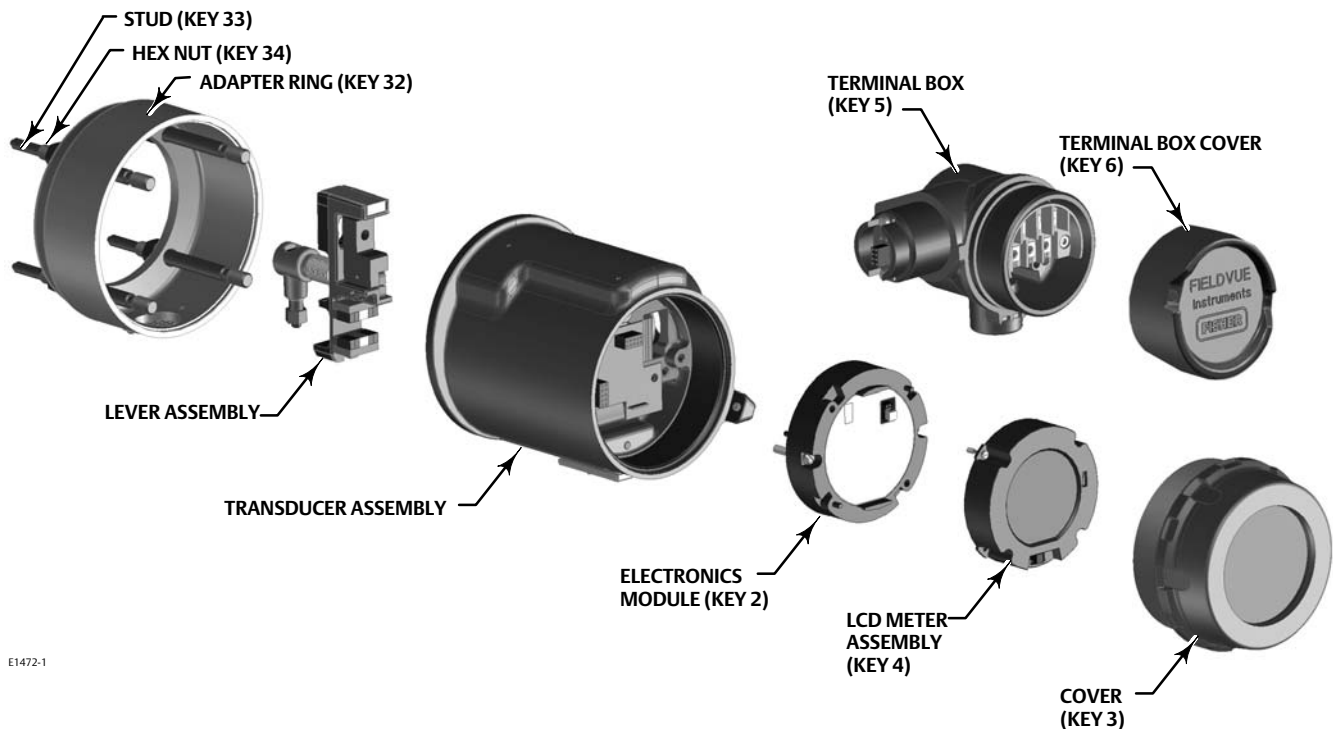

E1472-1

## Removing the LCD Meter

Perform the following procedure to remove the LCD meter.

1. Disconnect power to the digital level controller.
2. Remove the cover from the transducer housing. In explosive atmospheres, do not remove the instrument cover when the circuit is alive, unless in an intrinsically safe installation.
3. Loosen the two screws that anchor the LCD meter to the Electronics Module. These screws are captive and should not be removed.
4. Firmly grasp the LCD meter and pull it straight away from the Electronics Module. Retain the six-pin dual header for later reinstallation.

## Replacing the LCD Meter

Perform the following procedure to replace the LCD meter.

1. Verify that the interconnection header is in the six-pin socket on the face of the Electronics Module. The longer set of pins should be inserted in the Electronics Module socket.
2. Decide which direction to orient the meter. The meter can be rotated in 90-degree increments for easy viewing. Position one of the four six-pin sockets on the back of the meter to accept the interconnection header, and insert

the long meter screws into the two holes on the meter to coincide with the appropriate holes on the Electronics Module.

3. Attach the meter to the interconnection pins. Thread the long meter screws into the holes on the Electronics Module and tighten to secure the meter.
4. Note the position of the alarm jumper on the LCD meter removed from the digital level controller. Remove the alarm jumper and install it on the replacement meter in the same position.
5. Install the six-pin dual header on the LCD meter. Carefully insert the LCD meter to mate with the interconnecting pins with the receptacles on the Electronics Module .

## CAUTION

**To prevent damage to the interconnecting pins when installing the LCD Meter, use the guide pins to insert the LCD meter straight onto the Electronics Module, without twisting or turning.**

6. Replace the cover. Tighten 1/3 of a revolution after the cover begins to compress the O-ring. Both instrument covers must be fully engaged to meet explosion-proof or flame-proof requirements.

## Electronics Module

### Removing the Electronics Module

Perform the following procedure to remove the Electronics Module.

#### Note

The electronics are sealed in a moisture-proof plastic enclosure referred to as the Electronics Module. The assembly is a non-repairable unit; if a malfunction occurs the entire unit must be replaced.

## ⚠ WARNING

**On an explosion-proof instrument, remove the electrical power before removing the instrument covers in a hazardous area. Personal injury or property damage may result from fire and explosion if power is applied to the instrument with the covers removed.**

1. Disconnect power to the digital level controller.
2. Remove the cover from the transducer housing. In explosive atmospheres, do not remove the instrument cover when the circuit is alive, unless in an intrinsically safe installation. Remove the LCD meter assembly.
3. Loosen the two screws that anchor the Electronics Module to the transducer housing. These screws are captive and should not be removed.
4. Firmly grasp the Electronics Module and pull it straight out of the housing.

### Replacing the Electronics Module

Perform the following procedure to replace the Electronics Module.



1. Carefully insert the Electronics Module to mate the interconnecting pins with the receptacles on the Transducer housing.

### CAUTION

**To prevent damage to the interconnecting pins when installing the Electronics Module, use the guide pins to insert the Electronics Module straight onto the Transducer housing receptacles without twisting or turning.**

---

2. Tighten the two mounting screws. Replace the LCD meter assembly.
3. Replace the cover. Tighten 1/3 of a revolution after the cover begins to compress the O-ring. Both instrument covers must be fully engaged to meet explosion-proof requirements.

## Terminal Box

The terminal box is located on the transducer housing and contains the terminal strip assembly for field wiring connections. Unless indicated otherwise, refer to figure 7-3.

### ⚠ WARNING

**On an explosion-proof instrument, remove the electrical power before removing the instrument covers in a hazardous area. Personal injury or property damage may result from fire and explosion if power is applied to the instrument with the covers removed.**

---

## Removing the Terminal Box

1. Loosen the set screw (key 31) in the terminal box cover assembly (key 6) so that the cover can be unscrewed from the terminal box.
2. After removing the cover (key 6), note the location of field wiring connections and disconnect the field wiring from the wiring terminals.
3. Remove the screw (key 7), and pull out the terminal box assembly.

### CAUTION

**To avoid damaging the terminal box assembly connector, pull the terminal box assembly straight out of the housing, without twisting or turning.**

---

## Replacing the Terminal Box

### Note

Inspect all O-rings for wear and replace as necessary.

---

1. Apply sealant to the O-ring (key 27) and install the O-ring over the stem of the terminal box as shown in figure 7-3.
2. Orient the terminal box so that the connectors engage properly, and carefully insert the terminal box into the transducer housing until the O-ring is seated.

## CAUTION

**To avoid damaging the mating pins in the Transducer housing, ensure that the guiding mechanism is engaged properly before applying force.**

3. Fasten the terminal box to the transducer housing with the screw (key 7). Tighten the screw to 6 N•m (53 lbf•in).
4. Apply sealant to the O-ring (key 26) and install the O-ring over the cover threads on the terminal box. Use a tool to prevent cutting the O-ring while installing it over the threads.
5. Reconnect the field wiring as noted in step 2 in the Removing the Terminal Box procedure.
6. Apply lubricant to the threads on the terminal box to prevent seizing or galling while installing the terminal box cover.
7. Screw the terminal box cover assembly (key 6) completely onto the terminal box to seat the O-ring (key 26). Loosen the cover (not more than 1 turn) until the set screw (key 31) aligns with one of the recesses in the terminal box beneath the cover. Tighten the set screw to engage the recesses but no more than 0.88 N•m (7.8 lbf•in).
8. Apply lubricant to the conduit entrance plug (key 28) and install it in the unused conduit entrance.

## Removing and Replacing the Inner Guide and Access Handle Assembly

The access handle and inner guide are located on the transducer housing. Unless indicated otherwise, refer to figure 7-2.

1. Remove the digital level controller from the sensor as described in Removing the Digital Level Controller from the Sensor.
2. Loosen and remove the hex nuts (key 34) from the studs (key 33) and remove the adapter ring (key 32).

### Note

In the next step the screws (key 13) will be attracted by the magnets on the lever assembly. Use care to keep the screws from falling beneath the coupling shield.

3. Remove the coupling shield (key 16) by removing the two screws (key 13). Take care not to drop the screws into the lever assembly compartment where they will be attracted by the magnets.
4. Loosen and remove the two screws (key 13) in the handle assembly (key 12). Remove the handle assembly and the inner guide (key 11).
5. Apply thread lock to the internal threads of the replacement inner guide. Also apply a thin coat of a light grade of grease to the zero locking pin on the inner guide and on the surface that is opposite the zero locking pin, as shown in figure 6-3 (this surface contacts the transducer housing when installed).

Figure 6-3. Installing Inner Guide and Access Handle Assembly

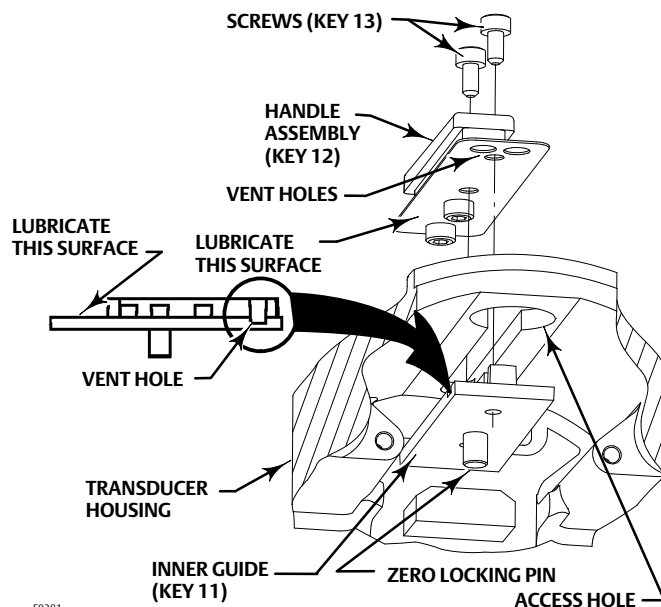

E0381

6. Place the inner guide in the slot inside the transducer housing so that the vent holes in the inner guide (the milled slots in the inner guide, see figure 6-3) face the exterior of the housing and are over the access hole.
7. Apply a thin coat of a light grade of grease to the surface of the replacement handle assembly (see figure 6-3) where it will contact the transducer housing.
8. Install the handle assembly (key 12) in the slot of the transducer housing over the inner guide (key 11) so that the vent holes in the handle assembly are over the access hole.
9. Install two screws (key 13) to secure the handle assembly (key 12) to the inner guide (key 11). Tighten the screws to 0.48 N•m (4.2 lbf•in).
10. Press down on the handle as shown in figure 2-4 and slide it forward to make sure it works smoothly and that the zero locking pin engages the lever assembly. Also check for free travel of the lever assembly when the handle is in the unlocked position.
11. Install the coupling shield (key 16) and secure with the two screws (key 13). Tighten the screws to 0.48 N•m (4.2 lbf•in).
12. Refer to figure 7-1. Install the adapter ring (key 32) on the studs (key 33) and secure with hex nuts (key 34).
13. When re-installing the digital level controller, follow the appropriate procedure outlined in the Installation section. Also setup the digital level controller as described in the Setup and Calibration section.

## Lever Assembly

### Removing the Lever Assembly

The lever assembly is located in the transducer housing. Unless indicated otherwise, refer to figure 7-2.

1. Remove the digital level controller from the sensor as described in Removing the Digital Level Controller from the Sensor.

2. Loosen and remove the hex nuts (key 34) from the studs (key 33) and remove the adapter ring (key 32).
3. Remove the coupling shield (key 16) by removing the two screws (key 13). Take care not to drop the screws into the lever assembly compartment where they will be attracted by the magnets.
4. Inspect the lever assembly alignment with the housing. If it is off center or not co-axial with the main housing, continue with the removal procedure.
5. Loosen and remove the mounting screw (key 14) from the lever assembly.
6. Loosen the flexure block from its machined pocket in the housing, by inserting a smooth tool into the hole for the mounting screw, and gently rocking it back and forth in what would be the vertical axis if the transmitter were installed.
7. Lift the lever assembly out of the housing.

Inspect the flexure for damage. If the flexure is bent or torn, replace the lever assembly.

## Replacing the Lever Assembly

Replacing the lever assembly in the field may result in a slight degradation in linearity performance, since the factory characterizes the entire transducer module as a unit. For most applications, this degradation should not be noticeable. (If guaranteed restoration to factory specification is desired, the entire transducer module should be replaced.)

1. Move the zero-pin slide to the locking position.
2. Apply a thin coat of a light grade of grease to the internal thread of the hole for the lever mounting bolt.
3. Hold lever assembly by coupling block and guide the flexure block into its aligning slot in the housing without applying any downward force to the sprung parts of the lever assembly.

### CAUTION

**To prevent damage to the flexure when inserting the flexure block into its aligning slot in the housing, apply pressure to the flexure block only.**

A long pin inserted into the bolt-hole in the flexure block may be used to pull it against the inside corner of the aligning slot.

4. Secure the block by reinstalling the M5x20 socket-head cap screw (key 14). Torque to 2.8 N•m (25 lbf•in)  $\pm$  10%.
5. Mark bolt head and block with a movement-detecting sealant.
6. Install the coupling shield (key 16) and secure with the two screws (key 13). Tighten the screws to 0.48 N•m (4.2 lbf•in).
7. Refer to figure 7-1. Install the adapter ring (key 32) on the studs (key 33) and secure with hex nuts (key 34). When re-installing the digital level controller, follow the appropriate procedure outlined in the Installation section. Set up the digital level controller as described in the Setup and Calibration section.

## Packing for Shipment

If it becomes necessary to return the unit for repair or diagnosis, contact your [Emerson sales office](#) or Local Business Partner for returned goods information.

### **CAUTION**

**Lock the lever assembly when shipping the stand-alone instrument, to prevent damage to the flexure.  
Use the original shipping carton if possible.**

---



## Section 7 Parts

### Parts Ordering

Whenever corresponding with your [Emerson sales office](#) or Local Business Partner about this equipment, always mention the controller serial number.

#### **⚠ WARNING**

Use only genuine Fisher replacement parts. Components that are not supplied by Emerson Automation Solution, should not, under any circumstances, be used in any Fisher instrument. The use of components not manufactured by Emerson may void your warranty, might adversely affect the performance of the instrument, and could cause personal injury and property damage.

### Mounting Kits

Contact your Emerson sales office or Local Business Partner for the following DLC3010 mounting options:

- Fisher 249 sensors - heat insulator for field mounting the DLC3010
- Masoneilan 12100, 12800 Series
- Masoneilan 12100, 12800 Series with heat insulator
- Masoneilan 12200, 12300 Series
- Masoneilan 12200, 12300 Series with heat insulator
- Yamatake Honeywell™ Type NQP
- Yamatake Honeywell Type NQP with heat insulator
- Foxboro-Eckardt 134LD and 144LD
- Foxboro-Eckardt 134LD and 144LD with heat insulator
- Foxboro-Eckardt LP167

- Foxboro-Eckardt LP167 with heat insulator

#### **Note**

Contact your Emerson sales office or Local Business Partner for information on the availability of additional mounting kits.

### Parts Kits

Description	Part Number
1* Small Hardware Spare Parts Kit	19B1643X052
Includes	Qty/kit
Screw (key 7)	1
Screw, hex socket (key 13)	6
Screw, cap, hex socket (key 14)	1
Set Screw (key 20)	2
Set Screw (key 31)	2
Test Terminal (key 24)	4
Wire Retainer (key 25)	8
Nut (key 34)	4
Alarm Jumper (key 35)	2
Header Assembly (key 38)	2
2* Spare O-Rings Kit	19B1643X022
Includes three each of keys 21, 26, and 27	
3* Coupling Hardware Spare Parts Kit	19B1643X042
Includes	Qty/kit
Clamp Nut (key 76)	1
Washer, Lock, Spring (key 77)	1
Bolt, lock, coupling block(key 82)	1

\*Recommended spare parts

# Parts List

**Note**

Contact your [Emerson sales office](#) or Local Business Partner for Part Ordering information.

## DLC3010 Digital Level Controllers (figure 7-1)

Key Description

- 1 Transducer Module<sup>(1)</sup>
- 2\* Electronics Ass'y<sup>(1)</sup>

Key	Description	Part Number
3	Cover Assy, includes O-ring (key 21)	
4	LCD Meter Ass'y, includes alarm jumper (key 35), header ass'y (key 38) and captive screws (key 40), and LCD Meter ass'y	28B5738X012
5*	Terminal Box Ass'y	28B5740X022
6	Terminal Box Cover Ass'y, includes labels (key 30 and 64) and set screw (key 31)	
7	Screw, hex socket <sup>(2)</sup>	
8	Nameplate	
9	Drive Screw	
21*	O-ring <sup>(3)</sup>	
32	Adaptor Ring	
33	Stud (4 req'd)	
34	Hex Nut (4 req'd)	
35	Alarm Jumper <sup>(2)(4)(5)</sup>	
36	Screw, captive For electronics ass'y (2 req'd) <sup>(4)</sup>	
38	Header Assembly, dual row (not shown) <sup>(2)(4)(5)</sup>	
40	Screw, captive For LCD meter (2 req'd) <sup>(5)</sup>	
66	Anti-Seize Sealant (not furnished with instrument)	
67	Thread locking adhesive (medium strength) (not furnished with instrument)	
70	Lithium grease (not furnished with instrument)	

Figure 7-1. DLC3010 Digital Level Controller Assembly

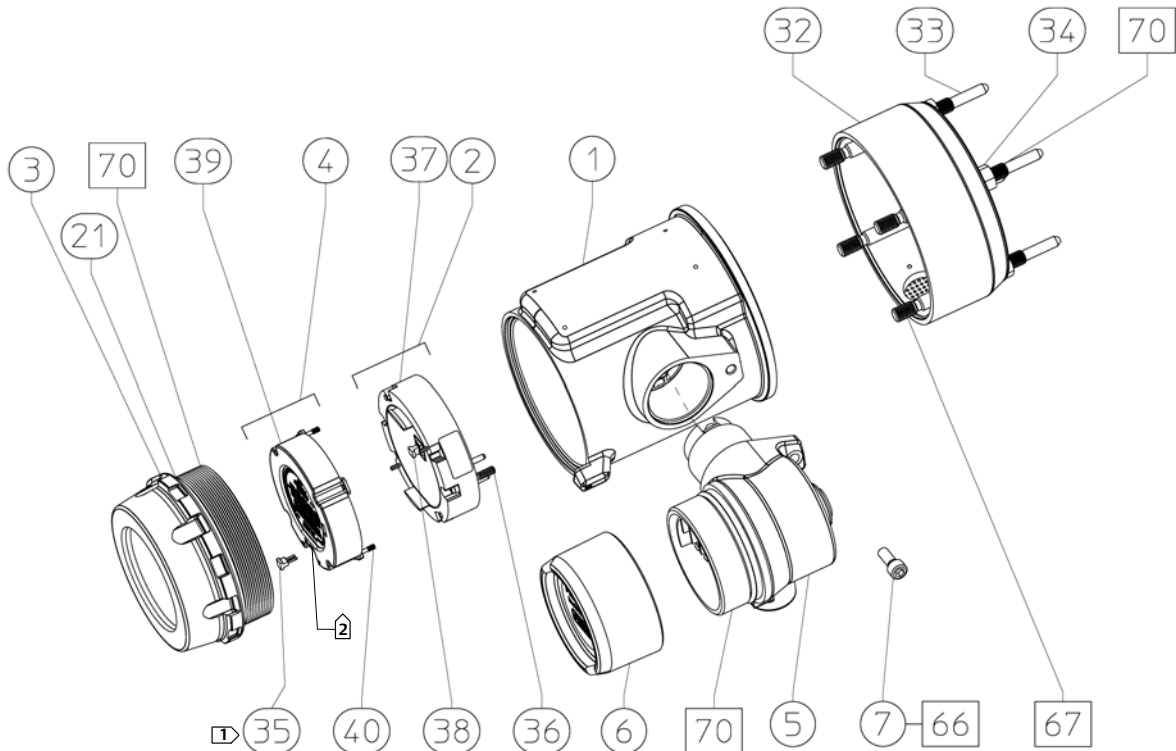

**NOTES:**

- 1 INSTALL ALARM JUMPER (KEY 35) ON ELECTRONICS ASSEMBLY (KEY 2) WHEN LCD METER (KEY 4) IS NOT INSTALLED.
- 2 LOCATION OF ALARM JUMPER (KEY 35) WHEN LCD METER (KEY 4) IS INSTALLED.

□ APPLY LUB/THREADLOCK

58B5510-E

**\*Recommended spare parts**

- 1. These parts are not replaced in the field due to serialization and characterization issues, but can be replaced at a qualified service center or Fisher Authorized Service Provider (FASP) that can issue nameplate. Contact your Emerson sales office or Local Business Partner for additional information.
- 2. Included in small hardware spare parts kit.
- 3. Included in spare O-rings kit.
- 4. Included in the Electronics Ass'y, key 2
- 5. Included in the LCD Meter Ass'y, key 4



Key	Description	Part Number
11	Inner Guide	
12	Handle Assy	
13	Screw, hex socket (4 req'd)	
14	Screw, cap	
15*	Lever Assembly	38B5509X042
16	Coupling Shield	
17	Ring, align/clamp	

Key	Description
19	Machine Screw, pan head
20	Set Screw <sup>(2)</sup>
31	Set Screw, hex socket <sup>(2)</sup>
67	Thread Locking adhesive (medium strength) (not furnished with instrument)
68	Sealant
76	Clamp Nut <sup>(2)</sup> <sup>(6)</sup>
77	Spring Lock Washer <sup>(2)</sup> <sup>(6)</sup>
79	Transducer Board Assembly <sup>(1)</sup>
80	Hall Guard
81	Compound, silicone
82	Bolt, lock, coupling block <sup>(6)</sup>

## Transducer Assembly (figure 7-2)

Figure 7-2. DLC3010 Digital Level Controller Transducer Assembly

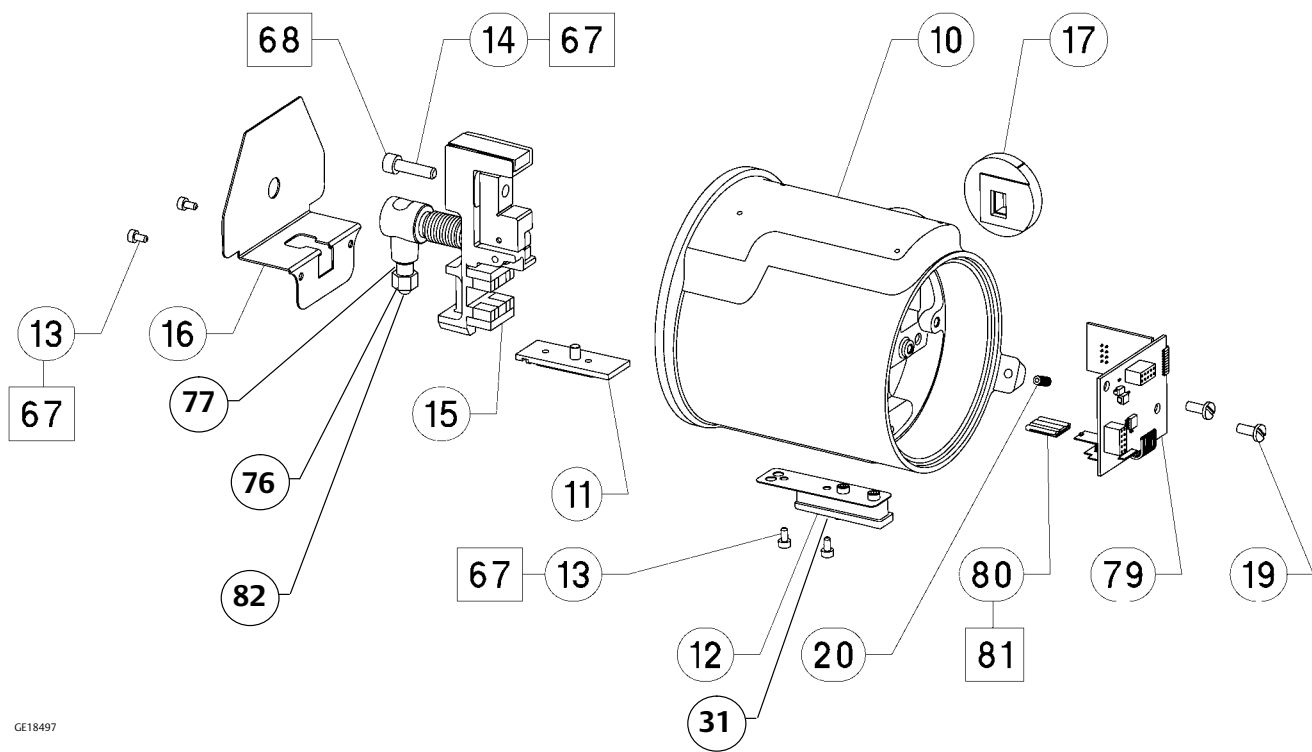

GE18497

**\*Recommended spare parts**

1. These parts are not replaced in the field due to serialization and characterization issues, but can be replaced at a qualified service center or Fisher Authorized Service Provider (FASP) that can issue nameplate. Contact your Emerson sales office or Local Business Partner for additional information.
2. Included in small hardware spare parts kit.
6. Included in Coupling Hardware Spare Parts Kit

Figure 7-3. Terminal Box Assembly

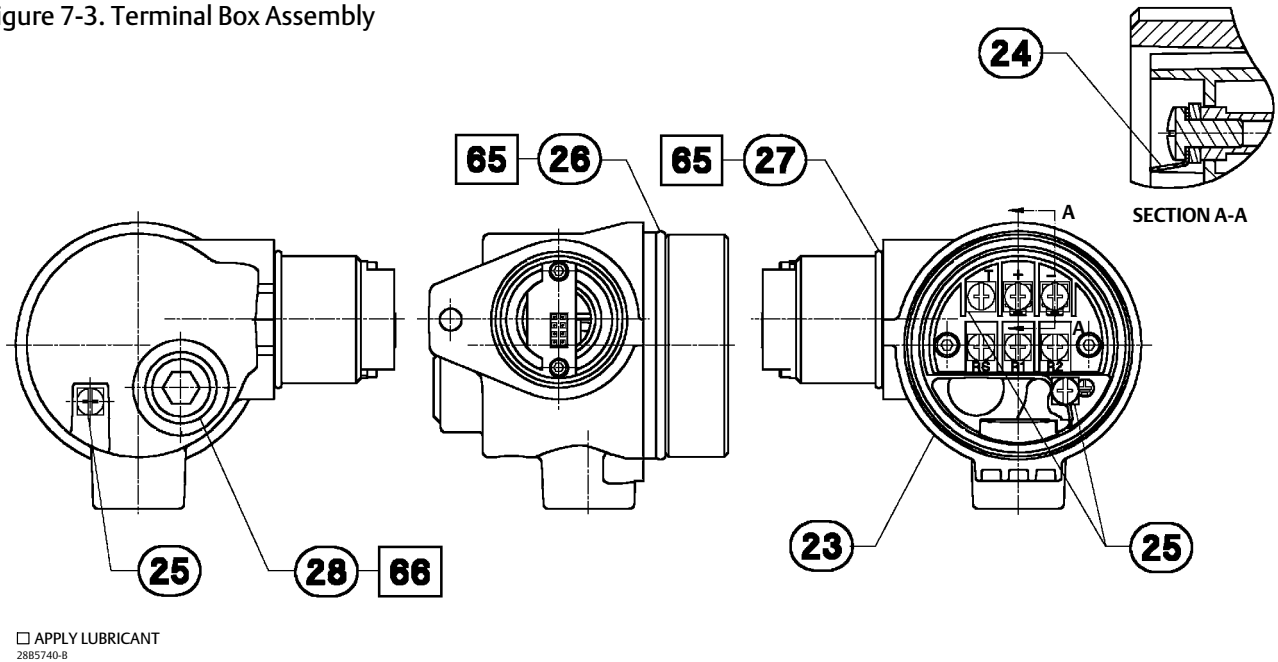

Key Description

### Terminal Box Assembly (figure 7-3)

- 24 Test Terminal (2 req'd)<sup>(2)</sup>
- 25 Wire Retainer (8 req'd)<sup>(2)</sup>
- 26\* O-Ring<sup>(3)</sup>
- 27\* O-Ring<sup>(3)</sup>

- 28 Pipe Plug
- 65 Lubricant, Silicone (not furnished with instrument)
- 66 Anti-Seize Sealant (not furnished with instrument)

### Terminal Box Cover Assembly (figure 7-4)

- 30 Label, internal
- 31\* Set Screw, hex socket<sup>(2)</sup>
- 64 Label, external

Figure 7-4. Terminal Box Cover Assembly

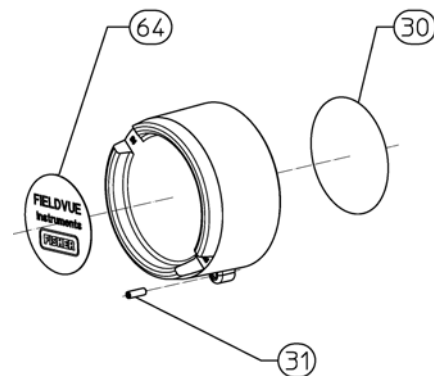

2885531-C

\*Recommended spare parts  
 2. Included in small hardware spare parts kit.  
 3. Included in spare O-rings kit.

Figure 7-5. Mounting Kit for 249 Sensors with Heat Insulator

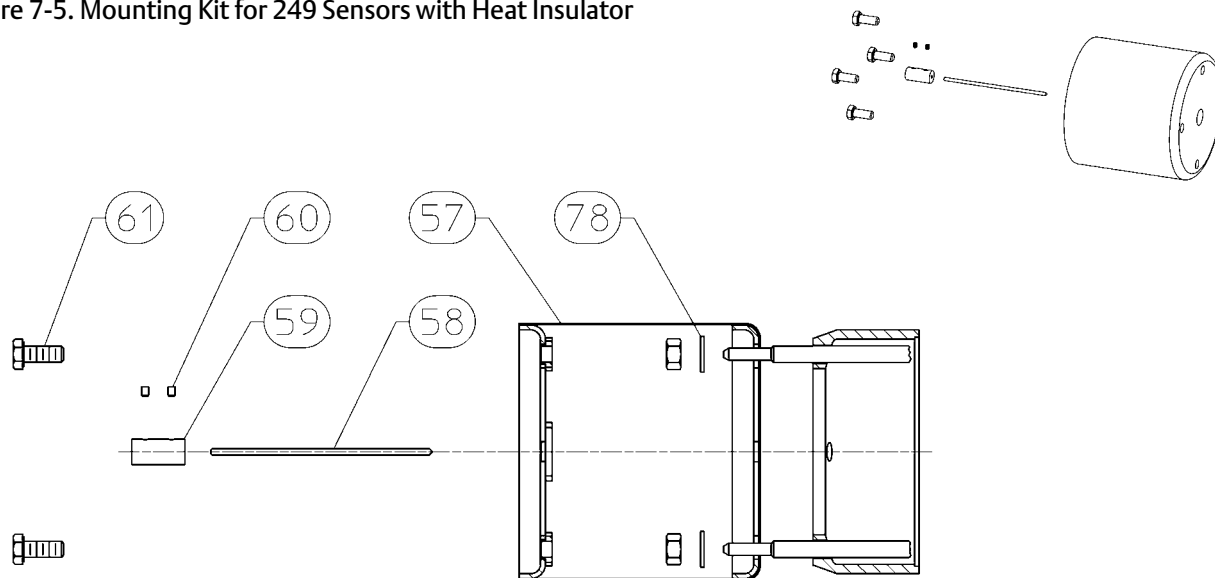

2885741-A

## Mounting Parts

These parts are available as a kit as indicated in the Mounting Kits section. Contact your [Emerson sales office](#) or Local Business Partner for these mounting options.

Key Description

### 249 Sensors with Heat Insulator (figure 7-5)

- 57 Heat Insulator
- 58 Shaft Extension
- 59 Shaft Coupling
- 60 Set Screw, hex socket (2 req'd)
- 61 Screw, hex hd (4 req'd)
- 78 Washer, plain (4 req'd)

Key Description

### Masoneilan Sensors (figures 7-6 and 7-7) 12100 or 12800 without Heat Insulator

- 58 Shaft Extension
- 59 Shaft Coupling
- 60 Set Screw, hex socket (2 req'd)
- 61 Screw, hex hd (4 req'd)
- 62 Mounting Adapter
- 63 Screw, hex socket, (4 req'd)

### 12100 or 12800 with Heat Insulator

- 57 Heat Insulator
- 58 Shaft Extension
- 59 Shaft Coupling
- 60 Set Screw, hex socket (2 req'd)
- 61 Screw, hex hd (4 req'd)
- 62 Mounting Adapter
- 63 Screw, hex socket (4 req'd)
- 78 Washer, plain (4 req'd)

Figure 7-6. Mounting Kit for Masoneilan 12200 and 12300 Sensor without Heat Insulator

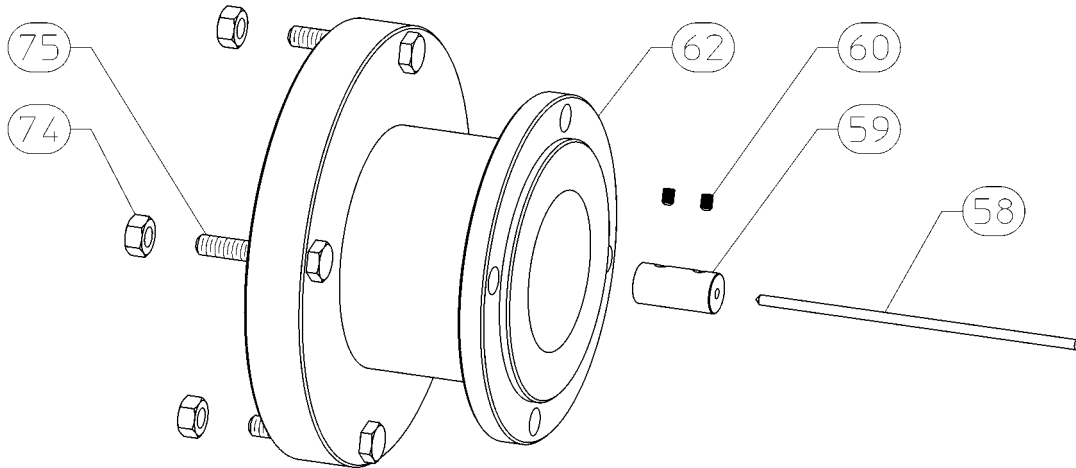

2988444-A

Figure 7-7. Mounting Kit for Masoneilan 12200 and 12300 Sensor with Heat Insulator

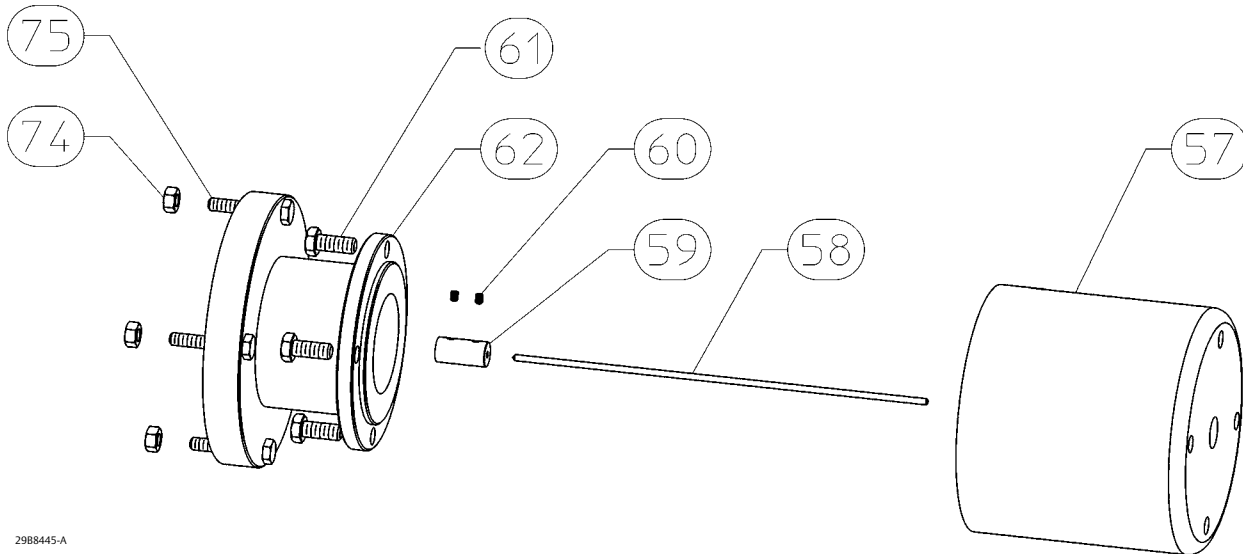

2988445-A

Key Description

12200 or 12300 without Heat Insulator

- 58 Shaft Extension
- 59 Shaft Coupling,
- 60 Hex Socket Screw (2 req'd)
- 62 Mounting Adaptor
- 74 Hex Nut (4 req'd)
- 75 Hex Cap Screw (4 req'd)

Key Description

12200 or 12300 with Heat Insulator

- 57 Heat Insulator
- 58 Shaft Extension
- 59 Shaft Coupling
- 61 Hex Cap Screw (4 req'd)
- 60 Hex Socket Screw (2 req'd)
- 62 Mounting Adaptor
- 74 Hex Nut (4 req'd)
- 75 Hex Cap Screw (4 req'd)
- 78 Washer, plain (4 req'd) not shown

Key Description

## Yamatake NQP Sensor

### Without Heat Insulator

- 58 Shaft Extension
- 59 Shaft Retainer
- 60 Hex Socket Screw
- 62 Mounting Adaptor
- 63 Hex Socket Screw (3 req'd)
- 71 Hex Socket Screw (3 req'd)
- 72 Shaft Adapter
- 73 Hex Socket Screw (2 req'd)

### With Heat Insulator

- 57 Heat Insulator
- 58 Shaft Extension
- 59 Shaft Retainer
- 60 Hex Socket Screw
- 61 Hex Cap Screw (4 req'd)
- 62 Mounting Adaptor
- 63 Hex Socket Screw (3 req'd)
- 71 Hex Socket Screw (3 req'd)
- 72 Shaft Adapter
- 73 Hex Socket Screw (2 req'd)
- 78 Washer, plain (4 req'd)

Key Description

## Foxboro-Eckardt Sensors

### 144LD without Heat Insulator

- 58 Shaft Extension
- 59 Shaft Coupling
- 60 Set Screw, hex socket (2 req'd)
- 62 Mounting Adapter
- 74 Hex Nut (4 req'd)
- 75 Hex Cap Screw, steel (4 req'd)

### 144LD with Heat Insulator

- 57 Heat Insulator
- 58 Shaft Extension
- 59 Shaft Coupling
- 60 Set Screw, hex socket (2 req'd)
- 61 Screw, hex hd (4 req'd)
- 62 Mounting Adapter
- 74 Hex Nut (4 req'd)
- 75 Hex Cap Screw (4 req'd)
- 78 Washer, plain (4 req'd)

### LP167 without Heat Insulator

- 58 Shaft Extension
- 59 Shaft Coupling
- 60 Set Screw, hex socket (2 req'd)
- 62 Mounting Adapter
- 63 Screw, hex socket, (4 req'd)



## Appendix A Principle of Operation

### HART Communication

The HART (Highway Addressable Remote Transducer) protocol gives field devices the capability of communicating instrument and process data digitally. This digital communication occurs over the same two-wire loop that provides the 4-20 mA process control signal, without disrupting the process signal. In this way, the analog process signal, with its faster update rate, can be used for control. At the same time, the HART protocol allows access to digital diagnostic, maintenance, and additional process data. The protocol provides total system integration via a host device.

The HART protocol uses the frequency shift keying (FSK) technique based on the Bell 202 communication standard. By superimposing a frequency signal over the 4-20 mA current, digital communication is attained. Two individual frequencies of 1200 and 2200 Hz are superimposed as a sinewave over the 4-20 mA current loop. These frequencies represent the digits 1 and 0 (see figure A-1). The average value of this sinewave is zero, therefore no DC value is added to the 4-20 mA signal. Thus, true simultaneous communication is achieved without interrupting the process signal.

Figure A-1. HART Frequency Shift Keying Technique

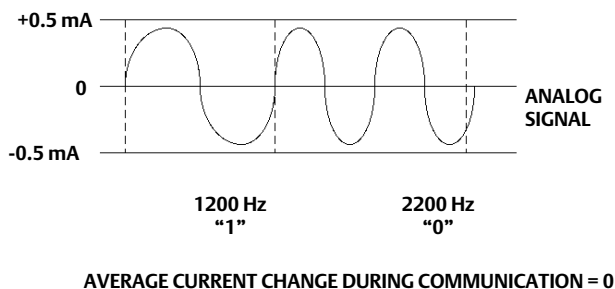

A6174

The HART protocol allows the capability of multidropping, networking several devices to a single communications line. This process is well suited for monitoring remote applications such as pipelines, custody transfer sites, and tank farms.

### Multidrop Communication

“Multidropping” refers to the connection of several digital level controllers or transmitters to a single communications transmission line. Communication between the host and the field instruments takes place digitally with the analog output of the instruments deactivated. With the HART communications protocol, up to 15 field instruments can be connected on a single twisted pair of wires or over leased phone lines. Multidrop installations are not recommended where intrinsic safety is a requirement.

The application of a multidrop installation requires consideration of the update rate necessary from each instrument, the combination of instrument models, and the length of the transmission line. Communication with the field instruments can be accomplished with commercially available Bell 202 modems and a host implementing the HART protocol. Each instrument is identified by a unique address (1-15) and responds to the commands defined in the HART protocol.

Figure A-2 shows a typical multidrop network. Do not use this figure as an installation diagram. Contact your [Emerson sales office](#) or Local Business Partner with specific requirements for multidrop applications.

Figure A-2. Typical Multidropped Network

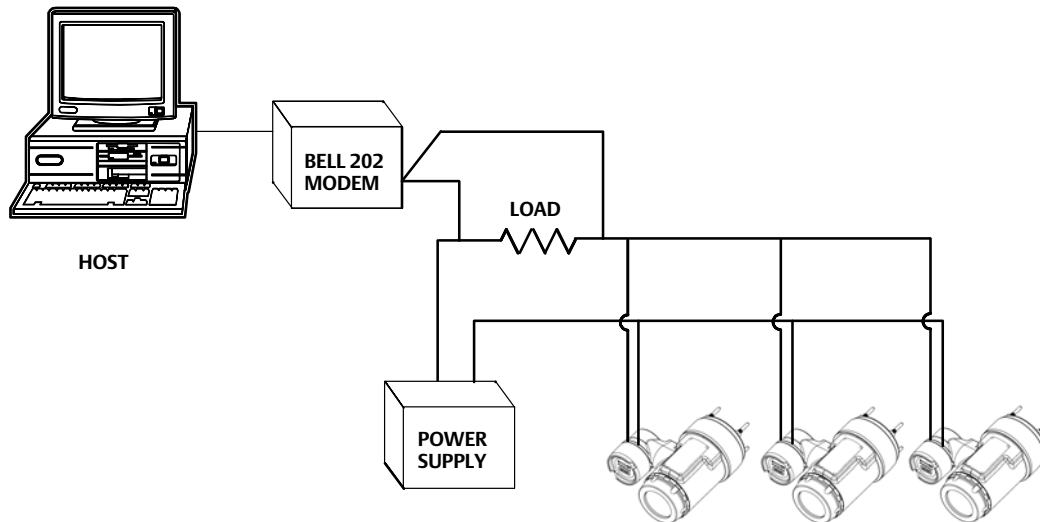

The Field Communicator can test, configure, and format a multidropped DLC3010 digital level controller in the same way as in a standard point-to-point installation, provided that it has been configured to scan for multiple polling addresses.

#### Note

DLC3010 digital level controllers are set to address 0 at the factory, allowing them to operate in the standard point-to-point manner with a 4-20 mA output signal. To activate multidrop communication, the address must be changed to a number between 1 and 15. This change deactivates the 4-20 mA analog output, sending it to 4 mA. The failure mode current also is disabled.

## Digital Level Controller Operation

The DLC3010 digital level controller is a loop-powered instrument that measure changes in liquid level, level of an interface between two liquids, or density of a liquid. Changes in the buoyancy of a displacer suspended in a vessel vary the load on a torque tube. The displacer and torque tube assembly constitute the primary mechanical sensor. The angular deflection of the torque tube is measured by the instrument transducer, which consists of a magnet system moving over a Hall effect device. A liquid crystal display (LCD) meter can display the analog output; process variable (level, interface level, or density); the process temperature, if an RTD (resistance temperature detector) is installed; the degrees of torque tube rotation; and percent range.

The instrument uses a microcontroller and associated electronic circuitry to measure the process variable, provide a current output, drive the LCD meter, and provide HART communications capability. Figure A-3 shows the digital level controller assembly. Figure A-4 is a block diagram of the main components in the instrument electronics; the LCD meter, the processor module, the transducer board, and the terminal board. The processor module contains the microprocessor, the analog-to-digital (A/D) converters, loop interface, signal conditioning, the digital-to-analog (D/A) output, power supply and interfaces to other boards.



Figure A-3. FIELDVUE DLC3010 Digital Level Controller Assembly

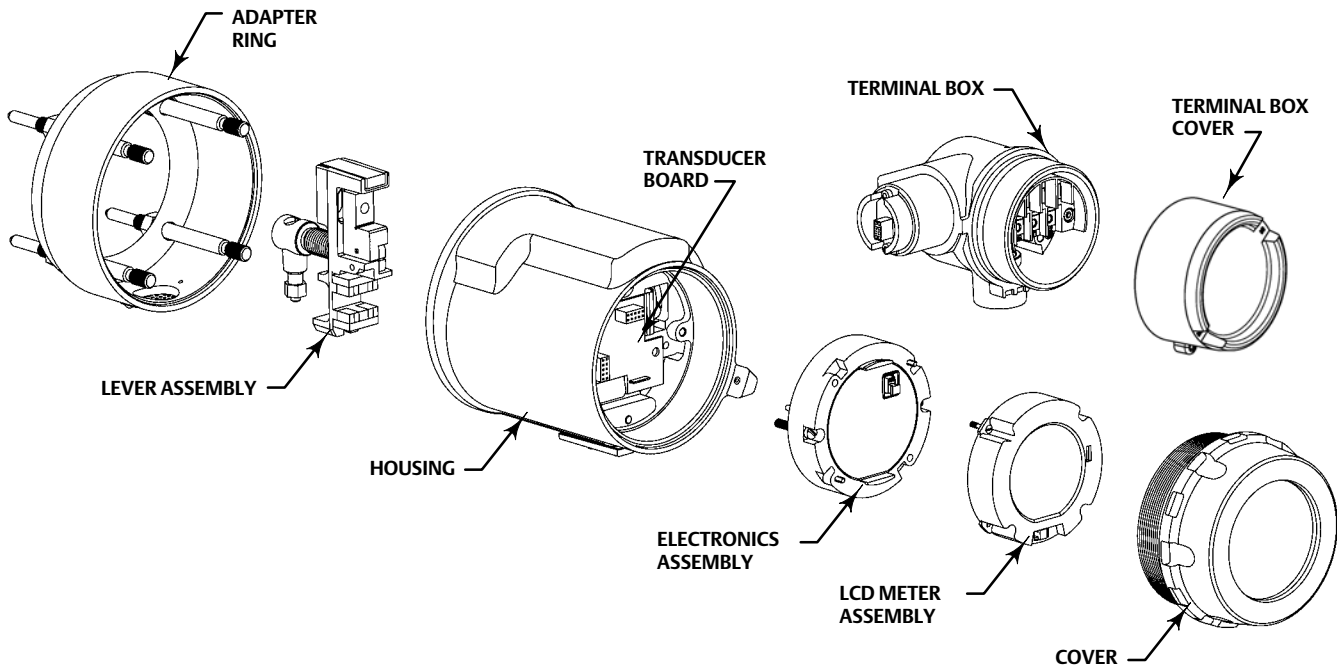
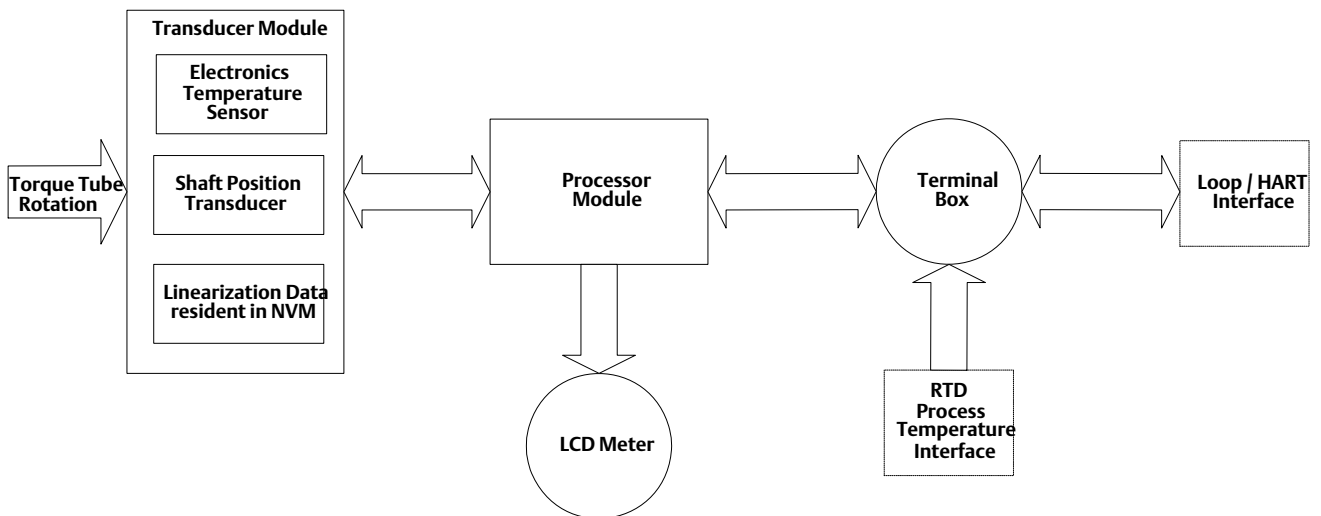

Figure A-4. FIELDVUE DLC3010 Digital Level Controller Principle of Operation



E0378

The transducer board contains the Hall sensor, a temperature sensor to monitor the Hall sensor temperature, and an EEPROM to store the coefficients associated with the Hall sensor. The terminal board contains the EMI filters, the loop connection terminals, and the connections for the optional RTD used to measure process temperature.

A level, density, or interface level change in the measured fluid causes a change in the displacer position (figure A-5). This change is transferred to the torque tube assembly. As the measured fluid changes, the torque tube assembly rotates up to 4.4 degrees for a 249 sensor, varying the digital level controller output between 4 and 20 mA.

Figure A-5. Typical Sensor Operation

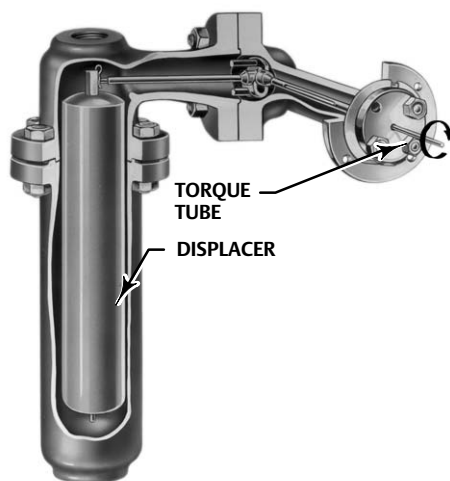

249 SENSOR (SIDE VIEW)

W1389-1

The rotary motion of the torque tube is transferred to the digital level controller lever assembly. The rotary motion moves a magnet attached to the lever assembly, changing the magnetic field that is sensed by the Hall effect sensor. The sensor converts the magnetic field signal to an electronic signal.

The microcontroller accepts the electronic signal, which is ambient-temperature-compensated and linearized. The microcontroller can also actively compensate for changes in liquid specific gravity due to changes in process temperature based on an input via HART protocol or via an optional RTD, if it is connected. The D/A output circuit accepts the microcontroller output and provides a 4 to 20 mA current output signal.

During normal operation, when the input is between the lower and upper range values, the digital level controller output signal ranges between 4 and 20 mA and is proportional to the input. See figure A-6. If the input should exceed the lower and upper range values, the output will continue to be proportional to the input until the output reaches either 3.8 or 20.5 mA. At this time the output is considered saturated and will remain at this value until the input returns to the normal operating range. However, should an alarm occur, the output is driven to either 3.7 or 22.5 mA, depending upon the position of the alarm jumper.

Figure A-6. Digital Level Controller Analog Output Signal

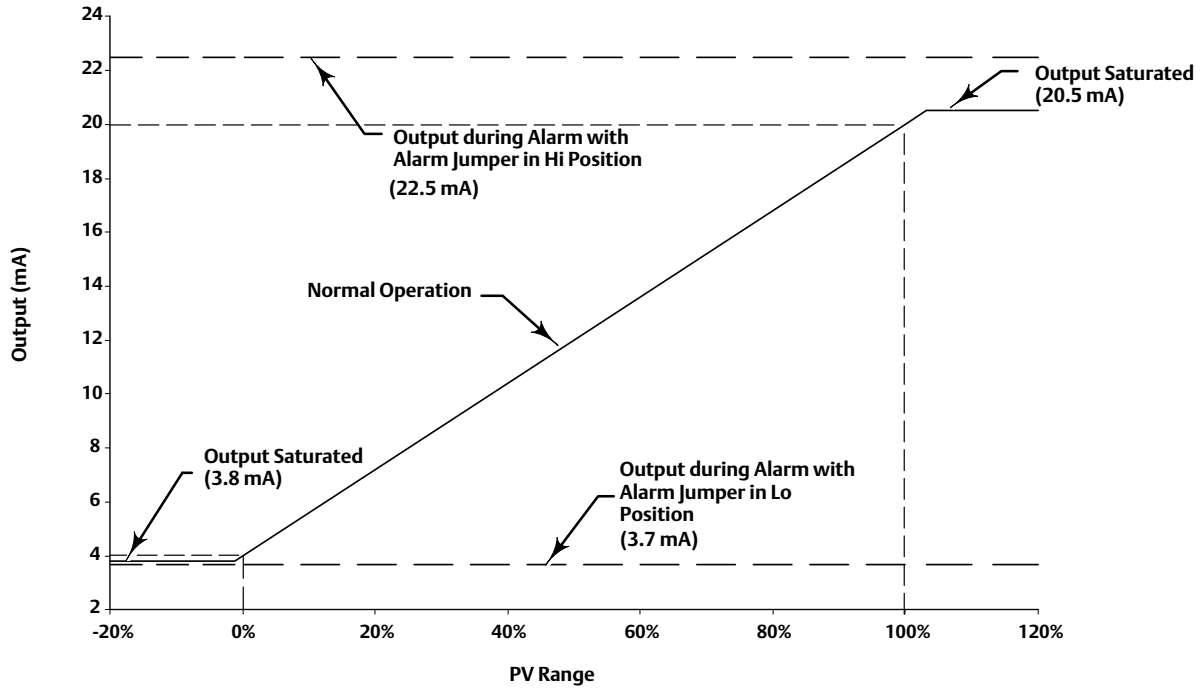

E0379

**Note**

The upper alarm value is compliant with NAMUR NE-43, but the lower alarm value is not.

If using in a system with NAMUR NE-43 compatibility, the high alarm value may be an appropriate choice.

Other circuits in the digital level controller provide reverse polarity protection, transient power surge protection, and electromagnetic interference (EMI) protection.



## Appendix B Fast-Key Sequence and Field Communicator Menu Tree

Fast-key sequences are included for common DLC3010 digital level controller functions. Also included are Field Communicator menu trees.

- Fast-key sequences, see table B-1
- Hot Key menu, see figure B-1
- Overview menu, see figure B-2
- Guided Setup menu, see figure B-3
- Manual Setup menu, see figure B-4
- Alert Setup menu, see figure B-5
- Communications menu, see figure B-6
- Calibration menu, see figure B-7
- Service Tools menu, see figure B-8

Table B-1. Fast Key Sequence

Function	Fast-Key Sequence	See Figure
Active Alerts	3-1	B-8
Alarm Jumper	1-7-3-1-1	B-2
Analog Output	1-5	B-2
	3-2-3	B-8
Burst Mode	2-4-1	B-6
Burst Option	2-4-2	B-6
Calibration, Full	2-5-1-2	B-7
Calibration, Partial	2-5-1-3	B-7
Calibration, Temperature	2-5-2-1	B-7
Change Process Temperature	2-2-3-2 <sup>(1)</sup>	B-4
	2-2-3-2-2 <sup>(2)</sup>	B-4
Change Primary Variable	2-2-2-1-2	B-1
Change Torque Rate	2-2-1-3-2	B-4
Comm Status	1-2	B-2
Date	1-7-1-8	B-2
	2-2-4-2	B-4
DD Information	1-7-2-5	B-2
Decimal Places	2-2-5-4	B-4
Descriptor	1-7-1-9	B-2
	2-2-4-3	B-4
Device ID	1-7-1-4	B-2
Device Status	1-1	B-2
Display Alert/Saturation Level	1-7-3-1-2	B-2
Display Mode	2-2-5-2	B-4
Distributor	1-7-1-2	B-2
Enter Constant Density	2-2-3-1-4 <sup>(2)</sup>	B-1
Field Device Revision	1-7-2-2	B-2
Final Assembly Number	1-7-1-7	B-2
	2-2-4-8-3	B-4
Firmware Revision	1-7-2-3	B-2
Guided Setup	2-1	B-3
Hardware Revision	1-7-2-4	B-2
HART Tag	1-7-1-1	B-2
	2-2-4-1	B-4
HART Universal Revision	1-7-2-1	B-2
Instrument Mounting	2-2-1-4	B-4
Instrument Serial Number	1-7-1-5	B-2
	2-2-4-8-1	B-4
Instrument Temperature	3-2-4	B-8
Instrument Temperature Alerts	2-3-2-1	B-5
LCD Configuration	2-2-5-1	B-4
LCD Test	3-3-1-1 <sup>(3)</sup>	B-8
Level Offset	2-2-2-1-4	B-4
Loop Test	3-3-1-1	B-8
	3-3-1-2 <sup>(3)</sup>	B-8
Lower Density Table	2-2-3-1-3-1 <sup>(4)</sup>	B-4
	2-2-3-1-3-2 <sup>(5)</sup>	B-4
Lower Fluid Density	2-2-3-1-1 or 3-2-7 <sup>(4)</sup>	B-4
	2-2-3-1-2 or 3-2-8 <sup>(5)</sup>	B-4
Lower Range Value	2-2-2-3-2	B-4
	2-3-1-4	B-5

Function	Fast-Key Sequence	See Figure
Lower Sensor Limit	2-2-2-2-2	B-4
Measure Density	2-2-3-1-4 <sup>(4)</sup>	B-4
Message	2-2-4-4	B-4
Minimum Span	2-2-2-2-3	B-4
Model	1-7-1-3	B-2
Number of Request Preambles	2-2-4-7	B-4
Percent Range	1-4-2	B-2
	3-2-2-2	B-8
Physical Signalling Code	2-2-4-6	B-4
Polling Address	2-2-4-5	B-4
Primary Variable Hi Alerts	2-3-1-1	B-5
Primary Variable Lo Alerts	2-3-1-2	B-5
Process Temperature	1-6-2	B-2
	2-2-3-2-3 <sup>(2)</sup>	B-4
	2-2-3-3 <sup>(1)</sup>	B-4
	3-2-5-2	B-8
Process Temperature Alerts	2-3-2-2	B-5
Process Temperature Source	1-6-1	B-4
	2-2-3-2-1 <sup>(2)</sup>	B-4
	2-2-3-3 <sup>(1)</sup>	B-2
	3-2-5-1	B-8
PV Alerts Threshold Deadband	2-3-1-6	B-5
PV is	1-3	B-2
	2-2-2-1-1	B-4
PV Units	2-2-2-1-3	B-4
PV Value	1-4-1	B-2
	3-2-2-1	B-8
Reset Device	3-3-2-2	B-8
Restore Factory Defaults	3-3-2-1	B-8
RTD Wire Resistance	2-2-3-2-4 <sup>(2)</sup>	B-4
	2-2-3-4 <sup>(1)</sup>	B-4
Scaled D/A Trim	2-5-2-2-1	B-7
Sensor Damping	2-2-1-5	B-4
Sensor Serial Number	1-7-1-6	B-2
	2-2-4-8-2	B-4
Sensor Units	2-2-1-1	B-4
	2-2-1-2	B-4
Set Level Offset	2-2-2-1-5	B-4
Temperature Deadband	2-3-2-3	B-5
Torque Rate	2-2-1-3-1	B-4
	3-2-6	B-8
Torque Tube Compensation Selection	2-2-1-3-4	B-4
Torque Tube Compensation Table	2-2-1-3-5	B-4
Torque Tube Material	2-2-1-3-3	B-4
Upper Density Table	2-2-3-1-3-1 <sup>(4)</sup>	B-4
Upper Fluid Density	2-2-3-1-1 <sup>(4)</sup>	B-4
	3-2-7 <sup>(4)</sup>	B-8
Upper Range Value	2-2-2-3-1	B-4
	2-3-1-3	B-5
Upper Sensor Limit	2-2-2-2-1	B-4
Write Lock	1-7-3-2-1	B-1
Write Lock Setup	1-7-3-2-2	B-1

1. If PV is Density  
 2. If PV is Level or Interface.  
 3. LCD Configuration is installed  
 4. If PV is Level  
 5. If PV is Interface

Figure B-1. Hot Key

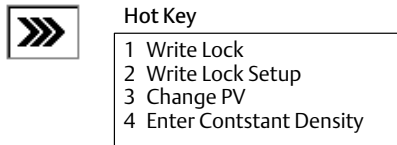

Figure B-2. Overview

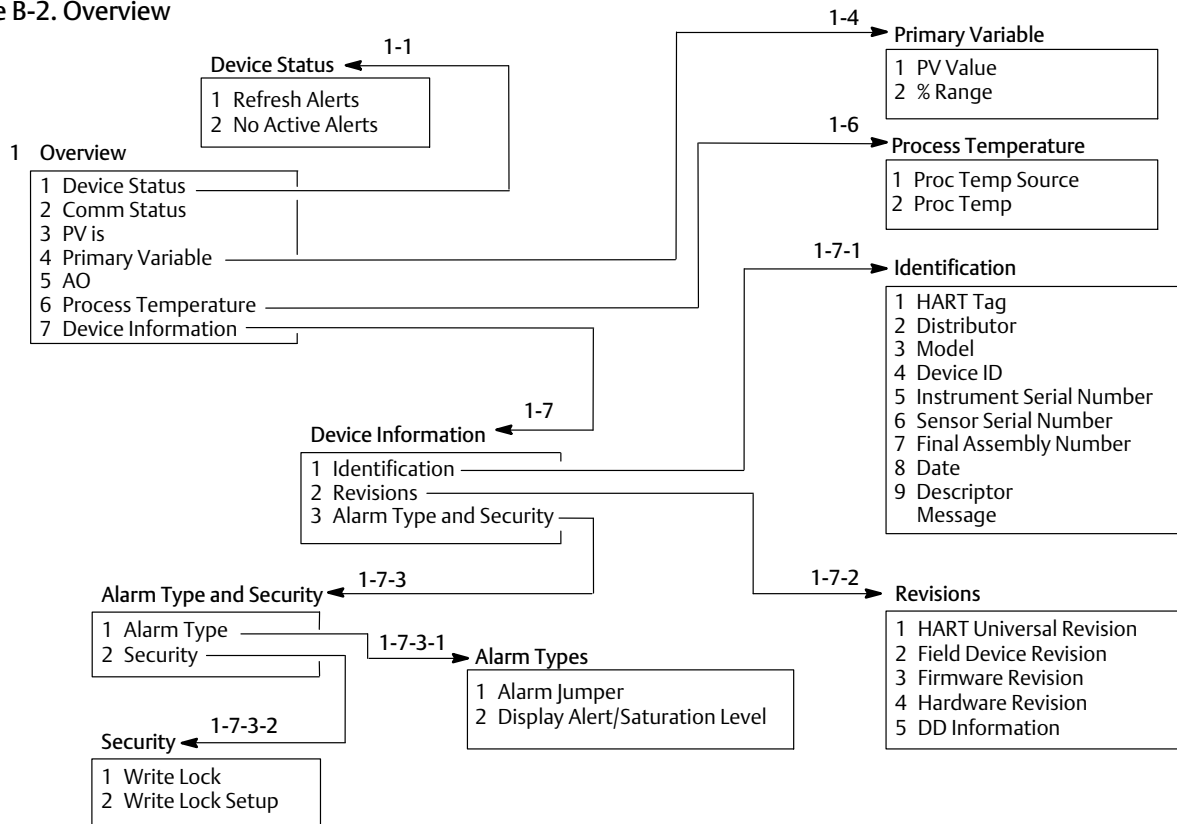

Figure B-3. Configure > Guided Setup

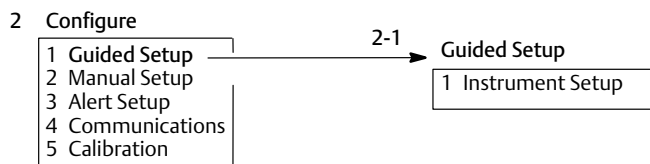

Figure B-4. Configure > Manual Setup

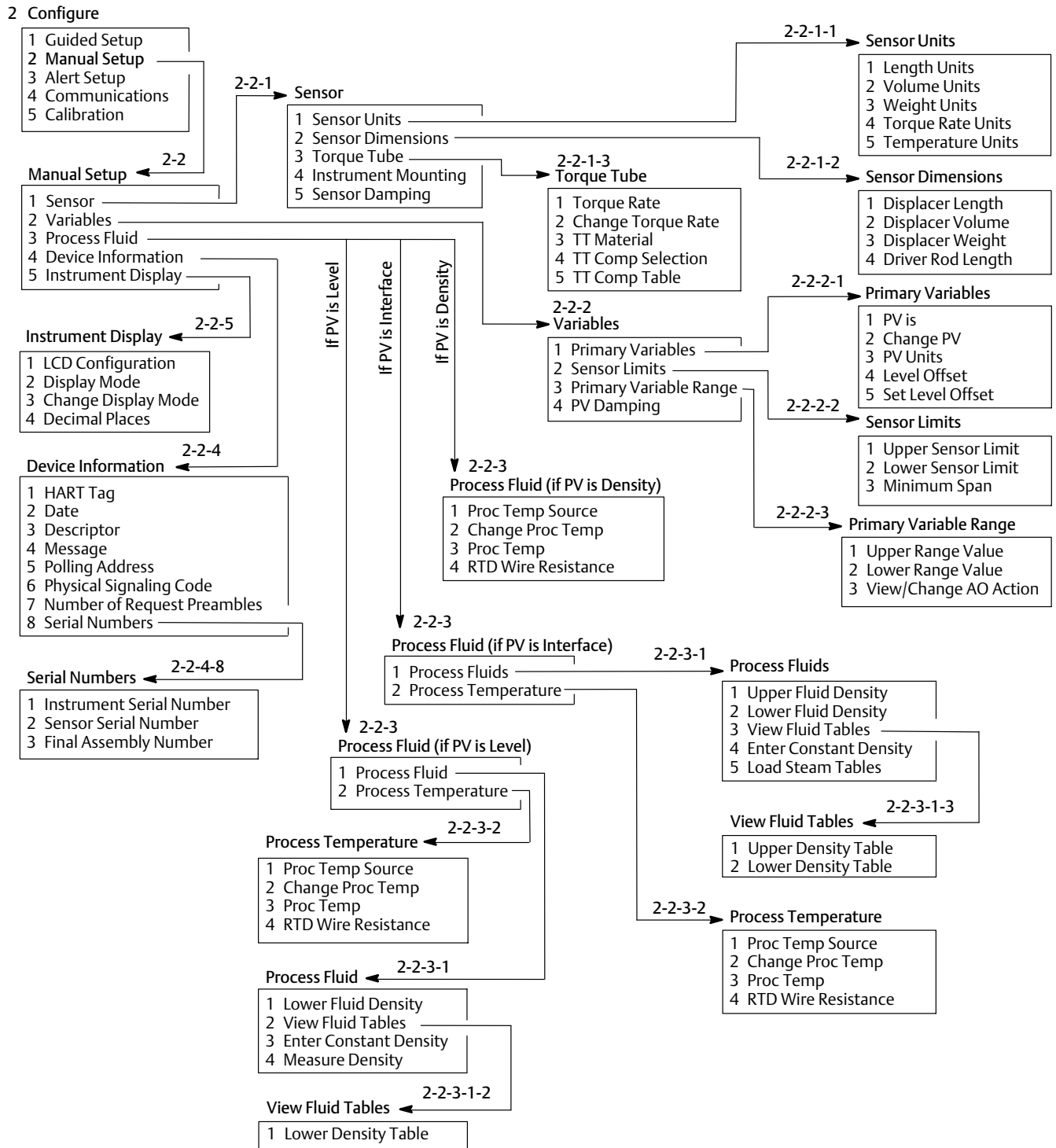



Figure B-5. Configure > Alert Setup

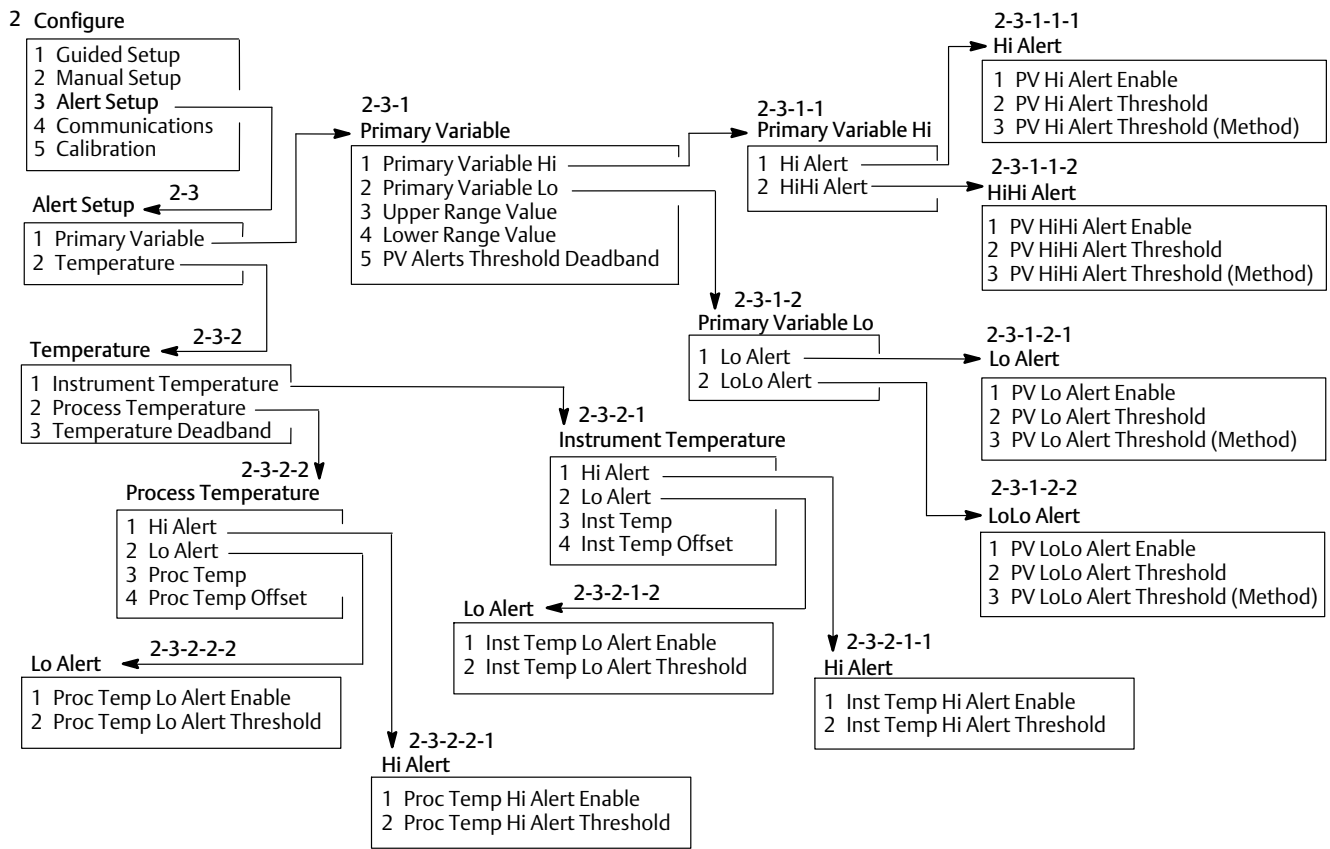

Figure B-6. Field Communicator Menu Tree—Configure > Communications

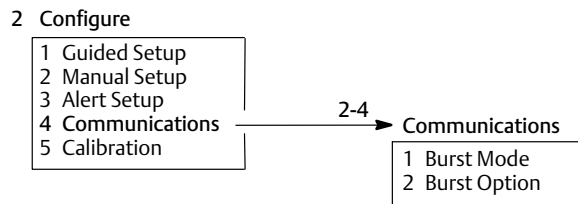

Figure B-7. Configure > Calibration

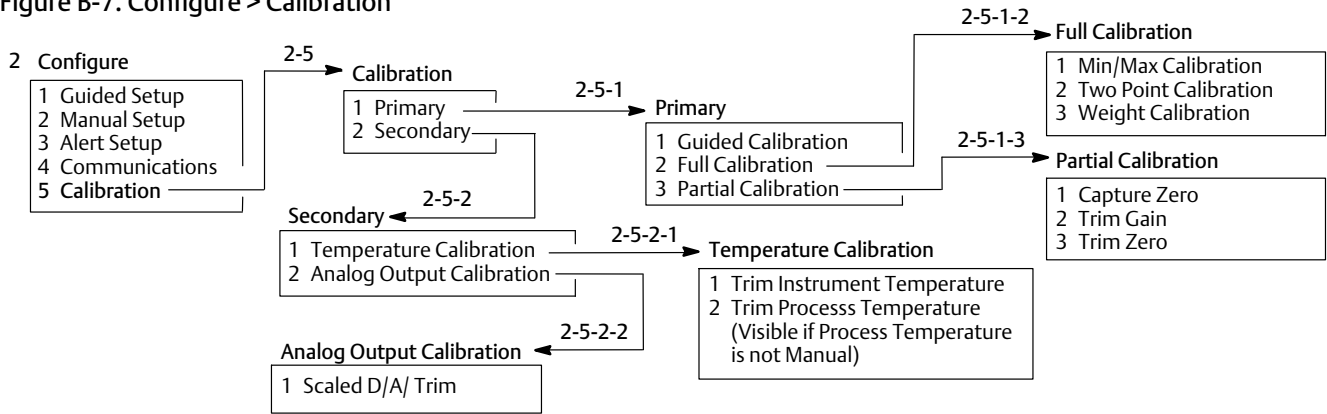
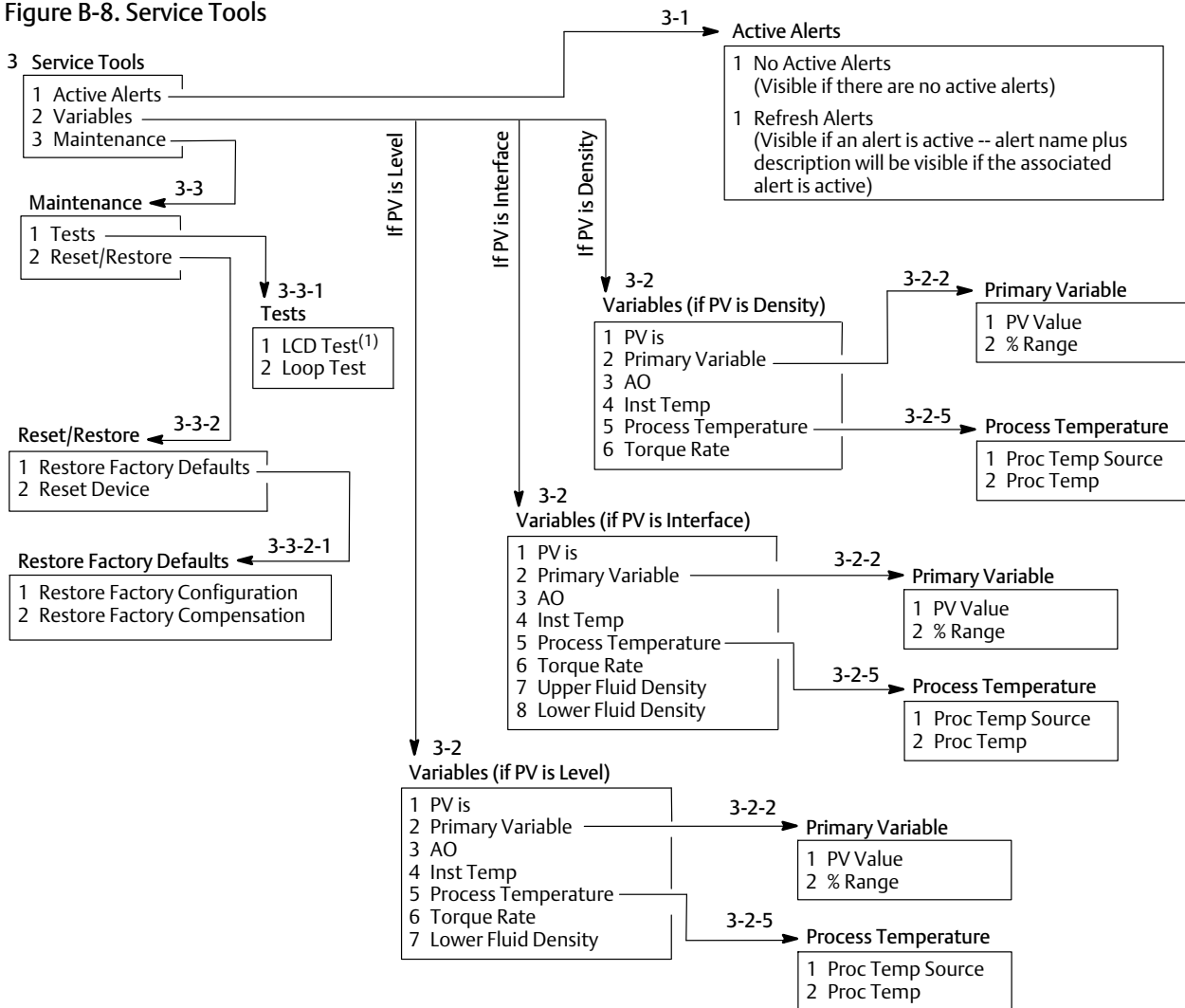

Figure B-8. Service Tools



1. LCD Test is visible if LCD Configuration is installed.

# Glossary

## Alarm Deadband

The amount by which the process variable must return within normal limits for the alarm to clear.

## Alarm Limit

An adjustable value that, when exceeded, activates an alert.

## Algorithm

A set of logical steps to solve a problem or accomplish a task. A computer program contains one or more algorithms.

## Alphanumeric

Consisting of letters and numbers.

## ANSI (acronym)

The acronym ANSI stands for the American National Standards Institute

## Burst

Burst mode is an extension to HART protocol that provides the continuous transmission of standard HART command response by a field device.

## Byte

A unit of binary digits (bits). A byte consists of eight bits.

## Commissioning

Functions performed with a Field Communicator and the digital level controller to test the instrument and loop and verify digital level controller configuration data.

## Configuration

Stored instructions and operating parameters for a FIELDVUE Instrument.

## Control Loop

An arrangement of physical and electronic components for process control. The electronic components of the loop continuously measure one or more aspects of the process, then alter those aspects as necessary to achieve a desired process condition. A simple control loop measures only one variable. More sophisticated control loops measure many variables and maintain specified relationships among those variables.

## Damping

Output function that increases the time constant of the digital level controller output to smooth the output when there are rapid input variations.

## Descriptor

Sixteen-character field for additional identification of the digital level controller, its use, or location. The descriptor is stored in the instrument and can be changed using a Field Communicator and the device information function.

## Device ID

Unique identifier embedded in the instrument at the factory.

## Device Revision

Revision number of the interface software that permits communication between the Field Communicator and the instrument.

## Firmware Revision

The revision number of the instrument firmware. Firmware is a program that is entered into the instrument at time of manufacture and cannot be changed by the user.

## Free Time

Percent of time that the microprocessor is idle. A typical value is 25%. The actual value depends on the number of functions in the instrument that are enabled and on the amount of communication currently in progress.

**Gain**

The ratio of output change to input change.

**Hardware Revision**

Revision number of the Fisher instrument hardware. The physical components of the instrument are defined as the hardware.

**HART (acronym)**

The acronym HART stands for Highway Addressable Remote Transducer. The communications standard that provides simultaneous analog and digital signal transmission between control rooms and field devices.

**HART Tag**

An eight-character field for identifying the digital level controller. The HART tag is stored in the instrument and can be changed using a Field Communicator and the device information function.

**HART Universal Revision**

Revision number of the HART Universal Commands which are the communications protocol for the instrument.

**Instrument Serial Number**

The serial number assigned to the instrument.

**Lower Range Value (LRV)**

Lowest value of the process variable that the digital level controller is currently configured to measure in the 4 to 20 mA loop.

**Lower Sensor Limit (LSL)**

Lowest value of the process variable that the digital level controller can be configured to measure.

**Memory**

A type of semiconductor used for storing programs or data. FIELDVUE instruments use three types of memory: Random Access Memory (RAM), Read Only Memory (ROM), and Non-Volatile Memory (NVM). See also these listings in this glossary.

**Menu**

A list of programs, commands, or other activities that you select by using the arrow keys to highlight the item then pressing ENTER, or by entering the numeric value of the menu item.

**Message**

Thirty-two character field for any additional information the user may want to include.

**Multidropping**

The connection of several field devices to a single communications transmission line.

**Non-Volatile Memory (NVM)**

A type of semiconductor memory that retains its contents even though power is disconnected. NVM contents can be changed during configuration unlike ROM which can be changed only at time of instrument manufacture. NVM stores configuration data.

**On-Line Configuration**

Configuration of the digital level controller operational parameters using a Field Communicator connected to the instrument.

**Parallel**

Simultaneous: said of data transmission on two or more channels at the same time.

**Polling Address**

Address of the instrument. If the digital level controller is used in a point-to-point configuration, set the polling address to 0. If it is used in a multidrop configuration, or split range application, set the polling address to a value from 0 to 15.

**Process Variable (PV)**

A physical quality or quantity which is monitored as part of a control strategy. The digital level controller can measure level, interface level between two liquids of different specific gravity, and liquid density.

**Protocol**

A set of data formats and transmission rules for communication between electronic devices. Devices that conform to the same protocol can communicate accurately.

**Random Access Memory (RAM)**

A type of semiconductor memory that is normally used by the microprocessor during normal operation that permits rapid retrieval and storage of programs and data. See also Read Only Memory (ROM) and Non-Volatile Memory (NVM).

**Read-Only Memory (ROM)**

A memory in which information is stored at the time of instrument manufacture. You can examine but not change ROM contents.

**Reranging**

Configuration function that changes the digital level controller 4 to 20 mA settings.

**RTD**

The abbreviation for resistance temperature detector. Temperature is measured by the RTD by correlating the resistance of the RTD element with temperature.

**Send Data**

A Field Communicator command that transfers configuration data from the Field Communicator's working register to the digital level controller memory.

**SI Units**

The International System of Units. Includes metric units such as ampere (A), meter (m), kilogram (kg), Kelvin (K), and second (s).

**Software**

Microprocessor or computer programs and routines that reside in alterable memory (usually RAM), as opposed to firmware, which consists of programs and routines that are programmed into memory (usually ROM) when the instrument is manufactured. Software can be manipulated during normal operation, firmware cannot.

**Span**

Algebraic difference between the upper and lower range values.

**Temperature Sensor**

A device within the instrument that measures the instrument's internal temperature.

**Upper Range Value (URV)**

Highest value of the process variable that the digital level controller is currently configured to measure in the 4 to 20 mA loop.

**Upper Sensor Limit (USL)**

Highest value of the process variable that the digital level controller can be configured to measure.

**Working Register**

Memory location in a Field Communicator that temporarily stores data as it is being entered.



# Index

## A

- access handle, 15
- Access Handle Assembly, removing and replacing, 82
- Active Alerts, Service Tools, 67
- Advisory, Device Status, 29
- Alarm Jumper, 25, 31
  - Changing Position, 26
- Alarm Type, 31
- alarm variables, default values, 36
- Alert Setup, 49
  - Primary Variable, 49
  - Temperature, 51
- Altitude Rating, 8
- Ambient Temperature, Operative, 249, 10
- AMS Suite: Intelligent Device Manager, 3
- Analog Output Calibration, 59
- Analog Output Signal, Digital Level Controller, 99
- AO, 29
  - Service Tools, Variables, 70
- Assembly, LCD Meter, 78
- ATEX approved units, 22, 26
- Available Configurations, 6

## B

- Bell 202 communication standard, 95
- [BLANK], Diagnostic Message, 73
- Burst, 29
- Burst Mode, Communications, 53
- Burst Operation, 28
- Burst Option, Communications, 53
- Burst Variables, 28, 53

## C

- Calibration
  - Analog Output, 59
  - Full, 55
  - Guided, 54
  - Min/Max, 55
  - Partial, 57
    - Capture Zero, 57
    - Trim Gain, 57
    - Trim Zero, 58
  - Scaled D/A Trim, 59
  - Temperature, 58
  - Theoretical, 56
  - Trim Instrument Temperature, 58
  - Trim Process Temperature, 58
  - Two Point, 55
  - Weight, 56
- Calibration , 54
- Calibration Examples, 60
  - Density Applications - with Standard Displacer and Torque Tube, 63
  - Sensor Calibration at Process Conditions (Hot Cut-Over) when input cannot be varied, 63
  - with an Overweight Displacer, 61
  - with Standard Displacer and Torque Tube, 60
- Capture Zero, Calibration, Partial, 57
- Change Display Mode, 48
- Change Proc Temp Source, process temperature, 46
- Change PV, 41
- Classifications/Certifications, 7
  - CUTR, 7
  - INMETRO, 7
  - KGS, 7
  - NEPSI, 7
  - PESO CCOE, 7
  - TIIS, 7
- Comm Status, 29
- Communications
  - Burst Mode, 53
  - Burst Option, 53
- Compensation
  - Density parameter, 7
  - manual, 7
  - Transducer, 7
- Configuration, digital level controller, 13

configuration data, factory, 33  
Connection Styles, Caged Sensor, 10  
Connections  
  Communication, 23  
  current loop, 20  
  Electrical, 20  
  Power/Current Loop, 23  
  RTD, 23  
  Test, 24  
Construction Materials, 8  
  249 Sensors, 10  
Coupling, 38  
  protecting, 13  
CUTR (Customs Union Technical Regulations), Russia,  
  Kazakhstan, Belarus, and Armenia, 7

## D

D/A Trim, 54  
Date, 30  
  Device Information, 47  
DD Information, 30  
Dead Band, 6  
Decimal Places, Instrument Display, 48  
Density, Process, DLC3010, 6  
Descriptor, 30  
  Device Information, 47  
Device ID, 30  
Device Information, 30, 47  
Device Revision, 30  
Device Status, 29  
Diagnostic Messages, LCD Meter, 73  
Diagnostics, 7  
Digital Monitors, 7  
digital-to-analog (D/A) output, 96  
Displacer  
  Length, 39  
  Volume, 39  
  Weight, 39  
Displacer Data  
  Serial Number, 47  
  Weight, 39  
Displacer Length, 54  
Displacer Lengths, Sensor, 10

Displacer Sensors  
  Caged, 11  
  Cageless, 11  
displacer serial number, 47  
Displacer Volume, 54  
Display Alert/Saturation Level, 31  
Display Mode, 48  
  change, 48  
Distributor, 30  
Driver Rod Length, 40, 54

## E

Educational Services, 5  
EEPROM, 98  
Electrical Classification, 7  
  Hazardous Area  
    ATEX, 7  
    CSA, 7  
    FM, 7  
    IECEX, 7  
Electrical Connections, 8, 20  
Electrical Housing, 7  
Electromagnetic Compatibility, 7  
electromagnetic interference (EMI) protection, 99  
electronics, encapsulated, 25  
Electronics Module  
  Removing, 80  
  Replacing, 80  
EMI filters, 98  
EN 61326-1:2013, Electromagnetic Compatibility, 7  
EN 61326-2-3:2006, Electromagnetic Compatibility, 7  
Enter Constant Density, process fluid, 45  
Equalizing Connections, 12

## F

FAIL HDWR, Diagnostic Message, 74  
Failed, Device Status, 29  
Fast-Key Sequence, 101  
Field Communicator Menu Tree, 101  
Field Device Revision, 30  
Field Wiring, 21  
Final Assembly Number, 47



Firmware Revision, 30  
 Flexures, protecting, 13  
 Full Calibration, 55

**G**

Good, Device Status, 29  
 ground strap, 22  
 Grounding, 22  
     Shielded Wire, 22  
 Guided Calibration, 54  
 Guided Setup, 34

**H**

Hall sensor, 98  
 Hardware Diagnostics, 74  
 Hardware Revision, 30  
 HART Communication, 7  
     Principle of Operation, 95  
 HART protocol, 95  
 HART Tag, 30, 47  
     Device Information, 47  
 HART Universal Revision, 30  
 Hazardous Area Classifications, 15  
 Heat Insulator, Installation, 18  
 Hi Alert, 49  
     Instrument Temperature, 51  
     Process Temperature, 52  
 Hi Hi Alert, 49  
 High High Alarm, 49  
 High Temperature Applications, 18  
 Hysteresis, 6  
 Hysteresis plus Deadband, 6

**I**

Immunity Performance, 8  
 Independent Linearity, 6  
 Initial Setup, 33  
 INMETRO, National Institute of Metrology,  
     Standardization, and Industrial Quality (Brazil), 7  
 Inner Guide and Access Handle Assembly, Removing  
     and Replacing, 82  
 Input Signal  
     249, 10  
     DLC3010, 6  
 Inst Temp, 51  
 Inst Temp Hi Alert Enable, 51  
 Inst Temp Hi Alert Threshold, 51  
 Inst Temp Lo Alert Enable, 51  
 Inst Temp Lo Alert Threshold, 51  
 Inst Temp Offset, 51  
 Installation, 13  
     249 Sensor, 15  
     DLC3010 on 249 Sensor, 18  
     Electrical, 20  
     Field Wiring, 21  
     Heat Insulator, 18  
     Multichannel, 24  
     Power/Current Loop Connections, 23  
     RTD Connections, 23  
 Installation Flowchart, 14  
 Instrument Display, Manual Setup, 47  
 Instrument Mounting, Specifying, 40  
 Instrument Serial Number, 47  
 Instrument Temperature  
     Alert Setup, 51  
     Service Tools, Variables, 70  
 Instrument Temperature Offset, 54  
 Interface Applications, Density Variations in, 65  
 interface level applications, 37  
 intrinsic safety, and multidrop installations, 95  
 intrinsically safe applications, 21

**K**

KGS, Korea Gas Safety Corporation (South Korea), 7

**L**

LCD Configuration, Instrument Display, 47

LCD meter, 17, 96

- Assembly, 78
- Diagnostic Messages, 73
  - [BLANK], 73
  - FAIL HDWR, 74
  - OFLOW, 74
- removing, 79
- Replacing, 79

LCD Meter Indications, 7

LCD Test, Maintenance, 71

Length Units, Sensor, 39

level measurement applications, 37

Level Offset, 41, 54

Level Signature Series Test, 8

Lever Assembly

- Removing, 83
- Replacing, 84

Lever Lock, 13

lift-off voltage, 20

Lo Alert, 50

- Instrument Temperature, 51
- Process Temperature, 52

Lo Lo Alert, 50

Load Steam Tables, process fluid, 45

loop connection terminals, 98

loop interface, 96

Loop Test, 26

- Maintenance, 71

Lower Density Table, 43

Lower Fluid Density

- process fluid, 43
- Service Tools, Variables, 70

Lower Range Value, primary variable, 42, 50

Lower Sensor Limit, 42

LRV (Lower Range Value), 54

**M**

Maintenance

- Device Status, 29
  - removing the DLC3010 from a 249 sensor
    - high temperature application, 78
    - standard temperature application, 77
- Reset/Restore, 71
- Service Tools, 71
- Tests, 71
  - LCD, 71
  - Loop, 71

Maintenance & Troubleshooting, 73

Manual Setup, 39

- Device Information, 47
- Instrument Display, 47

Materials

- 249, 10
  - Process Temperature, 10
  - Displacer and Torque Tube, 10

Measure Density, 65

- process fluid, 45

Mechanical Gain, excessive, 65

Message, 30

- Device Information, 47

microprocessor, 96

Min/Max Calibration, 55

Minimum Differential Specific Gravity, DLC3010, 7, 8

Minimum Span, sensor limits, 42

Model, 30

Model 375 Field Communicator, 3

modems, Bell 202, 95

moment arm, 34

Moment Arm (Driver Rod) Length, 35

Mounting

- 249 Sensor, 15
- Digital Level Controller Orientation, 17
- DLC3010, 15
  - On 249 Sensor, 18
- Typical Caged Sensor, 16
- Typical Cageless Sensor, 16

Mounting Kits, 87

Mounting Parts, 91

Mounting Positions

- 249 Series, 10
- DLC3010, 8
  - typical, DLC3010 digital level controller on 249 sensor, 17

Multichannel Installations, 24

Multidrop Communication  
 activating, 96  
 Principle of Operation, 95

Multidrop installations, intrinsic safety, 95

Multidropped Communication, Typical Multidropped  
 Network, 95

## N

NAMUR NE-43, 99

NEPSI, National Supervision and Inspection Centre for  
 Explosion Protection and Safety of  
 Instrumentation (China), 7

NVM (non-volatile memory), 58

## O

OFLOW, Diagnostic Message, 74

Output Signal, DLC3010, 6

Overview, 29

AO, 29

Comm Status, 29

Device Information, 30

Alarm Type and Security, 31

Identification, 30

Revisions, 30

Device Status, 29

Primary Variable, 29

Process Temperature, 30

PV is, 29

## P

Parts, Ordering, 87

Parts Kits, 87

Parts List, 88

(Percent) % Range, 29

Percent (%) Range Only, Display Mode, 48

PESO CCOE, Petroleum and Explosives Safety  
 Organisation - Chief Controller of Explosives  
 (India), 7

Polled, 29

polling address, 25, 96

Device Information, 47

Power Supply, Load Limits, 20

Power Supply Effect, 6

Power/Current Loop Connections, 23

Pressure Boundary Materials, allowable process  
 temperatures, 10

Primary Variable, 29

Alert Setup, 49

Service Tools, Variables, 69

Primary Variable Hi, Alert Setup, 49

Primary Variable Lo, Alert Setup, 50

Primary Variable Range, 42

Primary Variables, 41

Primary Variable Range, 42

PV Damping, 43

Sensor Limits, 42

Principle of Operation

DLC3010, 96

HART Communication, 95

Multidrop Communication, 95

Proc Temp Hi Alert Enable, 52

Proc Temp Hi Alert Threshold, 52

Proc Temp Lo Alert Enable, 52

Proc Temp Lo Alert Threshold, 52

Proc Temp Offset, 52, 54

Proc Temp Source, 30

Process Density, 6

Process Fluid, 43

Process Temperature, 30, 46, 48, 52

Alert Setup, 52

change source, 46

display, 46

Manual Entry of, 59

Service Tools, Variables, 70

source, 46

Process Temperatures, extreme, 66

process variable, 48

processor module, 96

Proportional Band, effect of, 65

Protection, 34, 39

PV, Display Mode, 48

PV alert deadband, 37

PV alert thresholds, 37

PV Alerts Threshold Deadband, 49, 50

PV Damping, 43

PV Hi Alert Enable, 49

PV Hi Alert Threshold, 49  
 method, 49

PV Hi Hi Alert Enable, 49

PV HiHi Alert Threshold, 49  
 method, 49

PV is, 29, 41  
 Service Tools, Variables, 69

PV Lo Alert Enable, 50

PV Lo Alert Threshold, 50  
 method, 50

PV LoLo Alert Enable, 50

PV LoLo Alert Threshold, 50  
 method, 50

PV Units, 41

PV Value, 29, 50

PV/% Range, Display Mode, 48

PV/Process Temperature, Display Mode, 48

## R

Related Documents, 5

remote indicator, 8

Repeatability, 6

replacement parts, 87

Reset/Restore, Maintenance, 71

Restore Factory Compensation, 71

Restore Factory Configuration, 71

Restore Factory Defaults , 71

returned goods information, 85

reverse polarity protection, 99

Revisions, 30

Rosemount 333 HART Tri-Loop HART-to-Analog Signal Converter, 27

RTD  
 Connections, 23  
 Three-Wire, 23  
 Two-Wire, 23  
 Setup, 46

RTD Wire Resistance, 46

## S

Saturated Water, Specific Gravity vs Temperature Table, example, 44

Scaled D/A Trim, Analog Output Calibration, 59

Security, 31

Sensor Connection Compartment, 16

Sensor Damping, 40

Sensor Dimensions, 39

Sensor Limits, 42

Sensor Nameplate, example, 35

Sensor Units, 39

Serial Number  
 Instrument, 47  
 Sensor, 47

Serial Numbers, Device Information, 47

Service Tools, 67  
 Maintenance, 71  
 Variables, 69

Set Level Offset, 41

SG, 54

shaft extension, torque tube, 18

signal conditioning, 96

Special Instructions for “Safe Use” and Installations in Hazardous Locations, 15

specific gravity tables, 43

Specific Gravity vs Temperature Table for Saturated Steam, example, 45

Specifications  
 249 Sensors, 10  
 DLC3010, 4

Supply Requirements, 7

## T

Temperature  
 Ambient, DLC3010, 6  
 Process, 6

Temperature Calibration, 58

Temperature Compensation, 66

Temperature Deadband, 51, 52

temperature sensor, 98

Temperature Units, Sensor, 39

terminal board, 96

Terminal Box, 22  
 maintenance, 81  
 Removing, 81  
 Replacing, 81

terminal box cover set screw, ATEX approved unit, 22

Test connections, 24

Test Terminals, 24, 76

Tests, Maintenance, 71

Theoretical Reversible Temperature Effect on  
 Common Torque Tube Materials, 9

Theoretical Torque Tube (TT) Rates, 64

TIIS, Technology Institution of Industrial Safety (Japan),  
 7

Tools, required for maintenance, 76, 77

Torque Rate  
 change, torque tube, 40  
 Service Tools, Variables, 70  
 torque tube, 40

Torque Rate Units, Sensor, 39

Torque Tube, data, 40

Torque Tube Compensation Selection, 40

Torque Tube Compensation Table, 40

Torque Tube Rate, 54

torque-tube correction, data tables, 40

transducer board, 96, 98

transient power surge protection, 99

Transient Voltage Protection, 6

Tri-Loop, 27  
 Configuring DLC3010 for use with, 27

Trim Gain, Calibration, Partial, 57

Trim Instrument Temperature, Calibration, 58

Trim Process Temperature, Calibration, 58

Trim Zero, Calibration, Partial, 58

Troubleshooting, 73

TT Comp Selection, torque tube, 40

TT Comp Table, torque tube, 40

TT Material, torque tube, 40

Turn Cells Off, 71

Two Point Calibration, 55

**U**

Upper Density Table, 43

Upper Fluid Density  
 process fluid, 43  
 Service Tools, Variables, 70

Upper Range Value, primary variable, 42, 50

Upper Sensor Limit, 42

URV (Upper Range Value), 54

**V**

Variables  
 alarm, default values, 36  
 Burst, 28, 53  
 Primary Variables, 41  
 Service Tools, 69

View Fluid Tables, process fluid, 43

View/Change AO Action, primary variable, 42

voltage, lift-off, 20

Volume Units, Sensor, 39

**W**

Weight, 8

Weight Calibration, 56

Weight Units, Sensor, 39

Wiring, Field, 21

Working Pressures, Sensor, 10

Write Lock, 31, 34 *See also* Protection

Write Lock Setup, 31

**Z**

zero buoyancy, 38

Zero Reference Angle, 54







Neither Emerson, Emerson Automation Solutions, nor any of their affiliated entities assumes responsibility for the selection, use or maintenance of any product. Responsibility for proper selection, use, and maintenance of any product remains solely with the purchaser and end user.

Fisher, FIELDVUE, DeltaV, and Tri-Loop are marks owned by one of the companies in the Emerson Automation Solutions business unit of Emerson Electric Co. Emerson Automation Solutions, Emerson, and the Emerson logo are trademarks and service marks of Emerson Electric Co. HART is a registered trademark of the FieldComm Group. All other marks are the property of their respective owners.

The contents of this publication are presented for informational purposes only, and while every effort has been made to ensure their accuracy, they are not to be construed as warranties or guarantees, express or implied, regarding the products or services described herein or their use or applicability. All sales are governed by our terms and conditions, which are available upon request. We reserve the right to modify or improve the designs or specifications of such products at any time without notice.

Emerson Automation Solutions  
Marshalltown, Iowa 50158 USA  
Sorocaba, 18087 Brazil  
Cernay, 68700 France  
Dubai, United Arab Emirates  
Singapore 128461 Singapore

[www.Fisher.com](http://www.Fisher.com)

