

Fisher™ D and DA Control Valves

Fisher D and DA single-port, high-pressure valves are widely used in oil and gas production industries. These valves are especially useful for either throttling or on/off control of liquids or gases which are gritty, sticky, or which have a tendency to build up on internal valve parts. The DA valve is also useful in angle piping or other applications where a self-draining valve is desired.

Unless otherwise noted, all NACE references are to NACE MR0175-2002.

Features

- **Heavy-Duty Construction**—Massive guiding (figure 1) positively aligns the valve plug in the seat ring for high pressure drop applications. The screwed-in seat ring completely encloses the seat ring gasket.
- **Easy Maintenance**—Screwed bonnet/body joint allows repair or maintenance with a minimum of tools.
- **Severe Service Capability**—Valve is available with VTC (ceramic) trim for service in very erosive applications. The valve plug is also available with a tungsten carbide tip and the seat ring can be fitted with a full-bore tungsten carbide insert for erosive service.
- **Meets Variety of Specifications**—Valve body and end connection constructions are available for API as well as ASME standards.
- **NACE Trim Standard**—NACE trim and bolting materials are standard for all applications. These materials comply with the requirements of NACE MR0175-2002.



W7859-1

Fisher D Valve with 657 Actuator

Specifications

Available Configurations

D: Globe valve with screwed-on bonnet, unbalanced post-guided valve plug, screwed-in seat ring, metal seat construction, and push-down-to-close valve plug action
 DA: Same as D valve except in angle configuration (figure 1)

Valve Sizes and End Connections⁽¹⁾

See table 1

Maximum Inlet Pressures and Temperatures⁽¹⁾⁽²⁾

See table 2

Maximum Allowable Pressure Drops⁽²⁾

Flow up: Capable of full rated pressure drops
 Flow down: See table 3 for pressure drop limits for ceramic trim

Shutoff Classification per ANSI/FCI 70-2 and IEC 60534-4

Standard: Class IV leakage
 Optional: Class V

Material Temperature Capabilities

-46 to 232°C (-50 to 450°F)

Construction Materials

Body, Bonnet, and Trim: See table 4
 Packing:
Standard: ■ Single or ■ double PTFE V-ring packing for pressure service
Optional: Double PTFE/Composition
 Standard Gaskets: S31600 (316 SST)

Flow Characteristic

Equal percentage

Flow Direction (see figure 1)

D: Flow up (through seat ring and past valve plug)
 DA: ■ Flow up (through seat ring and past valve plug) or ■ flow down (past valve plug and through seat ring)

Flow Coefficients and Noise Level Prediction

See table 5 or Fisher Catalog 12

Port, Yoke Boss, Stem Diameters, and Rated Travels

See table 6

Approximate Weights

NPS 1: 34 kg (75 pounds)
 NPS 2: 45 kg (100 pounds)

Options

■ Lubricator/isolating valve ■ VTC (ceramic) Trim with equal percentage characteristic (not available with Micro-Flute trim) ■ Tungsten Carbide trim (not available with Micro-Flute trim)

1. EN (or other) ratings and end connections can usually be supplied; consult your [Emerson sales office](#) or Local Business Partner.
 2. The pressure/temperature limits in this bulletin and in any applicable standard limitations should not be exceeded.

Contents

Features 1
 Specifications 2
 Tables
 Valve Sizes, Port Diameters, and End Connections . 3
 Rated Inlet Pressures and Temperatures 3
 Flow Down Pressure Drop Limits-
 Ceramic Trim Only 3
 Materials for Standard Trim Constructions 3

Flow Coefficient
 (C_v at Maximum Valve Plug Travel) 4
 Port, Yoke Boss, Stem Diameters,
 and Rated Travel Specifications 4
 Installation 5
 Ordering Information 5
 Dimensions 6

Table 1. Valve Sizes, Port Diameters, and End Connections

VALVE SIZE, NPS	PORT DIAMETER (INCHES)	SCREWED VALVE BODIES				FLANGED VALVE BODIES			
		3600 psi	6000 psi	9000 psi (WCC Steel DA Only)	10,000 psi (Except WCC Steel DA)	ASME			API
						CL150 through CL600	CL900 and CL1500	CL2500	10,000 lb. Spec A and C
1	0.25, 0.375, 0.5, 0.75	X ⁽¹⁾	X	---	---	X	X	X	---
2	0.25, 0.375, 0.5, 0.75, 1, 1.25	X	X	X	X	X	X	X	X

1. *X indicates available construction.

Table 2. Rated Inlet Pressures and Temperatures

VALVE SIZE, NPS	TYPE	PRESSURE RATING OR COLD WORKING PRESSURE LIMIT	PRESSURE ⁽¹⁾		TEMPERATURE	
			bar	psi	°C	°F
1 or 2	Screwed	CL900 and 1500	259	3750	38	100
			236	3425	232	450
		CL2500	431	6250	38	100
			394	5710	232	450
1 or 2	Flanged	9000	621	9000	38	100
		10,000	689	10,000	38	100
1 or 2	Flanged	CL150	20.0	290	38	100
			12.8	185	232	450
		CL300	51.7	750	38	100
			47.2	685	232	450
		CL600	103.4	1500	38	100
			94.5	1370	232	450
		CL900 and 1500	259	3750	38	100
			236	3425	232	450
CL2500	431	6250	38	100		
	394	5710	232	450		
1 or 2	Flanged	API 10,000	689	Spec A 10,000	121	250
			689	Spec C 10,000	121	250

1. LCC steel body per ASME B16.34 except C5 steel for all API bodies.

Table 3. Flow Down Pressure Drop Limits - Ceramic Trim Only

VALVE SIZE, NPS	SEAT RING DIAMETER, mm (INCHES)					
	6.4 (0.25)	9.5 (0.375)	12.7 (0.5)	19.1 (0.75)	25.4 (1)	31.8 (1.25)
Pressure Drop, bar						
1	414	414	414	193	---	---
2	689	689	689	462	262	165
Pressure Drop, psi						
1	6000	6000	6000	2800	---	---
2	10,000	10,000	10,000	6700	3800	2400

Table 4. Materials for Standard Trim Constructions

VALVE MATERIAL	BONNET MATERIAL	PLUG AND SEAT RING	VALVE STEM
LCC	LF2	S31600 (316 stainless steel) hard faced with CoCr-A (Alloy 6)	S20910
WCC			

Table 5. Flow Coefficient (C_v at Maximum Valve Plug Travel)

VALVE SIZE, NPS	PORT DIAMETER, mm (INCHES)	EQUAL PERCENTAGE D		EQUAL PERCENTAGE DA	
		Flow Up		Flow Down	
1	6.4 (0.25)	1.66		3.21	
	9.5 (0.375)	4.03		7.06	
	12.7 (0.5)	6.51		11.2	
	19.1 (0.75)	12.3		16.8	
2	6.4 (0.25)	1.66		3.21	
	9.5 (0.375)	4.03		7.06	
	12.7 (0.5)	6.82		12.1	
	19.1 (0.75)	14.1		21.2	
	25.4 (1)	23.7		31.8	
	31.8 (1.25)	34.5		44.9	

Table 6. Port, Yoke Boss, Stem Diameters, and Rated Travel Specifications in mm (Inches)

VALVE SIZE, NPS	PORT DIAMETER	STANDARD			OPTIONAL		
		Yoke Boss Diameter	Stem Diameter	Rated Travel	Yoke Boss Diameter	Stem Diameter	Rated Travel
1	6.4 (0.25)	54 (2-1/8)	9.5 (3/8)	19.1 (0.75)	71 (2-13/16)	12.7 (1/2)	19.1 (0.75)
	90 (3-9/16)				19.1 (3/4)	19.1 (0.75)	
2	6.4 (0.25)	71 (2-13/16)	12.7 (1/2)	19.1 (0.75)	90 (3-9/16)	19.1 (3/4)	19.1 (0.75)
	9.5 (0.375)						
	12.7 (0.5)						
	19.1 (0.75)						
	25.4 (1)						
31.8 (1.25)							

Figure 1. Typical Constructions

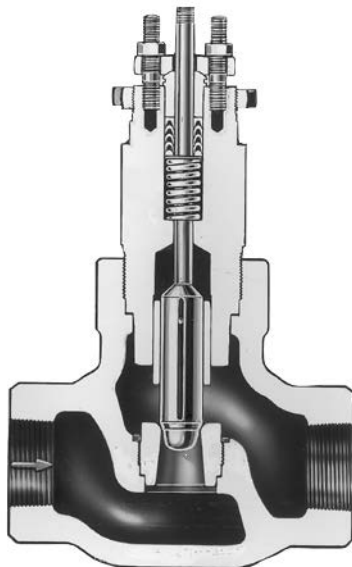

W0540-2

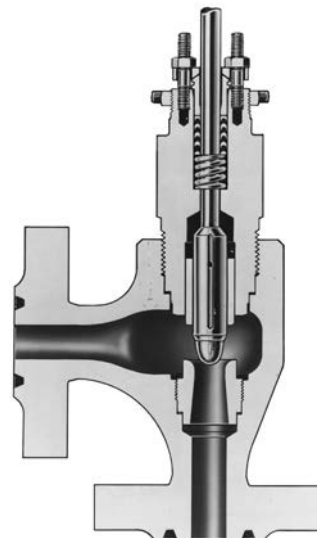

W0938-2

Installation

Valve orientation of the D and DA does not affect operation, but to facilitate changing trim parts, the valve stem should be vertical with the actuator above the valve. Proper flow direction is indicated by the arrow on the valve.

Dimensions are shown in figures 2 and 3.

Ordering Information

When ordering, specify:

Application

1. Type of application
 - a. Throttling or on-off
 - b. Reducing or relief
2. Controlled fluid (include chemical analysis of fluid, if possible)
3. Specific gravity of controlled fluid
4. Fluid temperature
5. Range of flowing inlet pressure

6. Pressure drops
 - a. Range of flowing pressure drops
 - b. Maximum at shutoff
7. Flow rates
 - a. Minimum controlled flow
 - b. Normal flow
 - c. Maximum flow
8. Maximum permissible noise level, if critical
9. Shutoff classification required
10. Line size and schedule

Valve

Refer to the specifications. Review the description for each specification. Indicate the desired choice whenever there is a selection (■) to be made. Always indicate the valve body design being ordered as identified in the available configuration specification.

Actuator and Accessories

Refer to separate bulletins covering actuators and accessories for ordering information.

Table 7. Fisher D Dimensions

FLANGED VALVE SIZE, NPS	ASME								D--All Ratings		
	CL150		CL300			CL600			Stem Size		
	A		A			A			Stem Size		
	A-Raised Face	G	Raised Face	Ring-Type Joint	G	Raised Face	Ring-Type Joint	G	9.5 (3/8)	12.7 (1/2)	19.1 (3/4)
	mm										
1	206	46	219	232	46	232	232	46	173	192	179
2	267	70	267	---	70	286	289	70	---	217	213
	Inches										
1	8.12	1.81	8.62	9.12	1.81	9.12	9.12	1.81	6.81	7.56	7.06
2	10.50	2.75	10.50	---	2.75	11.25	11.38	2.75	---	8.56	8.38

Table 8. Fisher D Dimensions

FLANGED VALVE SIZE, NPS	ASME						API			D--All Ratings		
	CL900 and 1500			CL2500			10,000 lb.			Stem Size		
	A			A			A			Stem Size		
	Raised Face	Ring-Type Joint	G	Raised Face	Ring-Type Joint	G	Spec A	Spec C	G	9.5 (3/8)	12.7 (1/2)	19.1 (3/4)
	mm											
1	254	254	46	308	308	54	---	---	---	173	192	179
2	308	311	70	391	394	83	364	360	83	---	217	213
	Inches											
1	10.00	10.00	1.81	12.12	12.12	2.12	---	---	---	6.81 ⁽¹⁾	7.56 ⁽¹⁾	7.06 ⁽¹⁾
2	12.12	12.25	2.75	15.38	15.50	3.25	14.34	14.19	3.25	---	8.56	8.38

1. Not applicable for 10,000 lb. API.

Table 9. Fisher D Dimensions

SCREWED VALVE SIZE, NPS	3600 psi		6000 psi and 9000 psi		D--All Ratings		
	A	G	A	G	Stem Size		
					9.5 (3/8)	12.7 (1/2)	19.1 (3/4)
	mm						
1 ⁽¹⁾	168	46	197	54	172	192	178
2	229	70	267	83	---	216	211
	Inches						
1 ⁽¹⁾	6.62	1.81	7.75	2.12	6.75	7.50	7.00
2	9.00	2.75	10.50	3.25	---	8.50	8.31

1. For 3600 psi and 6000 psi only.

Figure 2. Fisher D Dimensions (also see tables 7, 8, and 9)

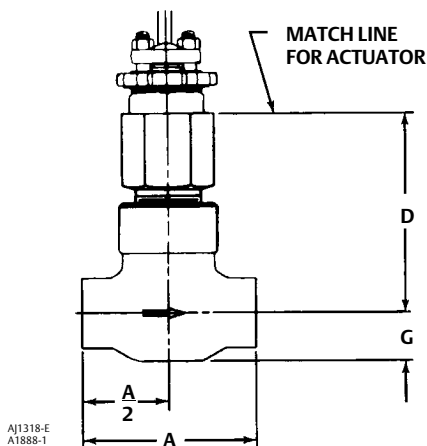

Table 10. Fisher DA Dimensions

FLANGED VALVE SIZE, NPS	A and G				D--All Ratings		
	ASME				Stem Size		
	CL300		CL600		9.5 (3/8)	12.7 (1/2)	19.1 (3/4)
	Raised Face	Ring-Type Joint	Raised Face	Ring-Type Joint			
	mm						
1	109	116	116	116	135	154	141
2	155	164	165	167	---	164	159
	Inches						
1	4.31	4.56	4.56	4.56	5.31	6.06	5.56
2	6.12	6.44	6.50	6.56	---	6.44	6.25

Table 11. Fisher DA Dimensions

FLANGED VALVE SIZE, NPS	A and G						D--All Ratings		
	ASME				API		Stem Size		
	CL900 and 1500		CL2500		10,000 lb.		9.5 (3/8)	12.7 (1/2)	19.1 (3/4)
	Raised Face	Ring-Type Joint	Raised Face	Ring-Type Joint	Spec A	Spec C			
	mm								
1	127	127	154	154	---	---	135	154	141
2	178	179	195	197	182	180	---	164	159
	Inches								
1	5.00	5.00	6.06	6.06	---	---	5.31	6.06	5.56
2	7.00	7.06	7.69	7.75	7.17	7.09	---	6.44	6.25

Table 12. Fisher DA Dimensions

SCREWED VALVE SIZE, NPS	3600 psi		6000 psi and 9000 psi		D--All Ratings		
	A	G	A	G	Stem Size		
					9.5 (3/8)	12.7 (1/2)	19.1 (3/4)
	mm						
1 ⁽¹⁾	76	89	89	102	133	152	140
2	102	124	114	130	---	162	157
	Inches						
1 ⁽¹⁾	3.00	3.50	3.50	4.00	5.25	6.00	5.50
2	4.00	4.88	4.50	5.12	---	6.38	6.19

1. For 3600 psi and 6000 psi only.

Figure 3. Fisher DA Dimensions (also see tables 10, 11, and 12)

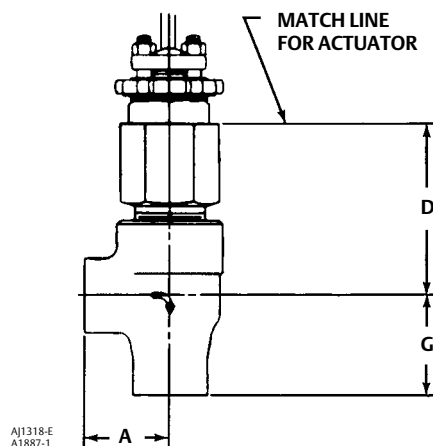

Neither Emerson, Emerson Automation Solutions, nor any of their affiliated entities assumes responsibility for the selection, use or maintenance of any product. Responsibility for proper selection, use, and maintenance of any product remains solely with the purchaser and end user.

Fisher is a mark owned by one of the companies in the Emerson Automation Solutions business unit of Emerson Electric Co. Emerson Automation Solutions, Emerson, and the Emerson logo are trademarks and service marks of Emerson Electric Co. All other marks are the property of their respective owners.

The contents of this publication are presented for informational purposes only, and while every effort has been made to ensure their accuracy, they are not to be construed as warranties or guarantees, express or implied, regarding the products or services described herein or their use or applicability. All sales are governed by our terms and conditions, which are available upon request. We reserve the right to modify or improve the designs or specifications of such products at any time without notice.

Emerson Automation Solutions
Marshalltown, Iowa 50158 USA
Sorocaba, 18087 Brazil
Cernay 68700 France
Dubai, United Arab Emirates
Singapore 128461 Singapore

www.Fisher.com

