



## KTM HINDLE ULTRA-SEAL BALL VALVES

### SERIES 300

A range of two piece full bore, flanged, free floating (seat supported) ball valves, incorporating mounting dimensions to BS EN 15081, featuring soft, metal and carbon seated designs



#### FEATURES

- Two piece full bore design, flanged construction in carbon steel, stainless steel and special alloys.
- Designed in accordance with ASME B16.34, BS EN ISO 17292 & ISO 14313/API 6D.
- Floating ball design for bi-directional shut-off.
- Flexing soft seat design for superior shut-off across a range of pressures with minimum operating torque.
- Low temperature and cryogenic designs for service down to -196°C available on request.
- Spring energized metal and carbon seat designs permitting tight shut-off and positive cavity pressure relief.
- Fused hard nickel alloy, chromium carbide or tungsten carbide coated seat and ball designs for abrasive and high temperature service.
- Hard carbon seat design for medium temperature applications.
- High integrity shaft seal minimizing the potential for atmospheric leakage.
- Fugitive emission performance to BS EN ISO 15848-2 class A.
- Corrosion resistant trim. Standard valves incorporate balls and shafts of stainless steel for long service life.
- Fire test certified. All sizes and pressure ratings are covered by approved certification.
- Anti-static and blow-out proof shaft design.
- Most designs offer cavity pressure relief to upstream in event of thermal expansion.
- Could be integrated into a SIL 3 environment safety instrumented system.

#### SEAT DESIGN

There are three seat designs within the two piece Ultra-Seal Series 300 range.

- PTFE soft seat design for non abrasive service.
- Hard carbon seat design for clean applications.
- Metal seat design for abrasive service.

A range of one piece Series 110/200 Ultra-Seal reduced bore valves are also available.

#### DESIGN RANGE

Full bore NPS ½ - 8 (DN 15 - 200)  
Pressure class 150 & 300 depending on seat design.

#### Option

Full bore one piece soft seated design ball valve range is also available on request.



# KTM HINDLE ULTRA-SEAL BALL VALVES

## SERIES 300

### VALVE APPLICATIONS

Ultra-Seal ball valves are ideally suited for use in a wide variety of industries including petrochemical, chemical, oil and gas, LNG and marine with a choice of seat designs.

PTFE seat applications	Cryogenic temperatures down to -196°C and non abrasive services up to 230°C depending on the grade of material. Vacuum service down to 0.1 mbar.A.
Carbon seat applications	Clean service from -20°C up to 300°C, suitable for use with organic solvents. Ideally suited for Purified Terephthalic Acid (PTA).
Metal seat applications	Clean or Abrasive services from -50°C up to 450°C and/or applications where positive cavity relief is required together with bi-directional flow.

Soft seated valve sizes NPS ½ - 16 (DN 15 - 400) reduced bore available in 1-piece Series 110/200.

Metal/carbon seated valve sizes NPS 1 - 6 (DN 25 - 150) reduced bore. Also available in 1-piece Series 110/200.

### VALVE SEAT DESIGN RANGE

Class	Seat type	NPS ½ - 2	NPS 3 - 6	NPS 8
		DN 15 - 50	DN 80 - 150	DN 200
150	Soft	✓	✓	✓
	Metal/Carbon	✓	✓	
300	Soft	✓	✓	✓
	Metal/Carbon	✓	✓	

### TECHNICAL SPECIFICATIONS

Design	BS EN ISO 17292 (BS 5351)	ISO 14313/API 6D <sup>[2]</sup>
	BS EN 1983	ASME B16.34
Face to face <sup>[1]</sup>	BS EN 558	ASME B16.10
Fire testing	BS EN ISO 10497	
Pressure testing	BS ISO 5208	API 598
	BS EN 12266-1	ISO 14313/API 6D <sup>[2]</sup>
Material certification	BS EN 10204	NACE MR 0175-2002
		MR0103 & ISO 15156-2:2003 on request
Quality assurance	EN 29001	
	BS EN ISO 9001-2008	
ISO top mounting details	BS EN 15081	

### NOTES

1. Long and short patterns available.
2. Conformity to ISO 14313/API 6D is limited to all class 150 valves and class 300 up to NPS 6 (DN 150).

### STANDARD OPERATOR FOR SOFT SEATS

Class	NPS	DN	Lever	T-Bar	Gearbox
			Class 150	½ - 2	15 - 50
Class 300	½ - 2	15 - 50	3 & 4	80 & 100	6 & 8 150 & 200

### STANDARD OPERATOR FOR METAL/CARBON SEATS

Class	NPS	DN	Lever	T-Bar	Gearbox
			Class 150	½ - 2	15 - 50
Class 300	½ - 2	15 - 50			3 - 6 80 - 150

### STANDARD OPERATOR FOR SOFT SEATS

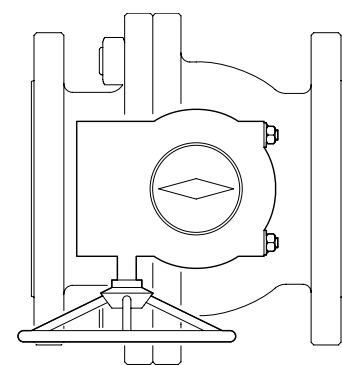

# KTM HINDLE ULTRA-SEAL BALL VALVES

## SERIES 300

### FACE TO FACE STANDARD ASME B16.10/BS EN 558 CLASS 150

NPS	DN	Short	Long
1/2 - 1 1/2	15 - 40	✓	✓
2	50	✓	✓
3	80	✓	✓
4	100	✓	✓
6	150	✓	
8	200	✓	

### FACE TO FACE STANDARD ASME B16.10/BS EN 558 CLASS 300

NPS	DN	Short	Long
1/2 - 1 1/2	15 - 40	✓	✓
2	50	✓	✓
3	80	✓	✓
4	100	✓	✓
6	150	✓	
8	200		✓

#### NOTE

These tables identify the standard face to face length of Ultra-Seal ball valves. Alternative pattern lengths are available on request.

### SOFT SEATED DESIGN FEATURES

Ultra-Seal soft seated ball valves utilize PTFE seats for maximum chemical compatibility combined with minimum coefficient of friction.

#### Temperature range

Suitable for a range of non abrasive service temperatures between -196°C and 230°C, depending on the seat material.

#### Seat design

The seat rings incorporate a flexing design which ensures positive sealing across the pressure range, even at low differential pressures. Slots on the external diameter ensure pressure equalisation between the upstream and the valve cavity, reducing the load on the downstream seat and minimizing operating torques.

#### Seat leakage

Floating ball design provides tight shut-off in both directions to BS ISO 5208 rate A.

#### Fugitive emissions

High integrity shaft seals give low emission performance, even under thermal cycling. Tested and approved to Shell MESC SPE 77/312 class A up to DN 40, NPS 1 1/2 and class B for sizes DN 50, NPS 2 and above. Meets the leakage performance of BS EN ISO 15848-2 class A.

### METAL SEATED DESIGN FEATURES

Ultra-Seal metal seated ball valves incorporate proven metal seated technology together with advanced ball/seat coatings, spring materials & low emission seals.

#### Temperature range

Suitable for a range of service temperatures between -50°C and 450°C for fluids carrying abrasive particles and where positive cavity relief is required.

For temperatures above 300°C, heat dissipation bonnets are available for gland isolation outside lagging area. Refer to page 4 for minimum bonnet lengths.

#### Coatings

A range of ball & seat coating materials are available providing hardness values from 60 HRC up to 75 HRC and coating thicknesses between 500 µm and 200 µm.

#### Seat design

Body & seat design ensures controlled spring compression, giving optimum seat & seal performance, together with constant running torque.

Spring and seat seals are protected from the main flowstream to prevent jamming and premature seat failure.

#### Seat leakage

The live loaded seat design gives reliable bi-directional sealing to BS ISO 5208 rate A in sizes up to DN 50, NPS 2 and rate B for DN 80, NPS 3 and above. Leak rates to ANSI/FCI 70-2 are also applicable to class VI up to DN 50, NPS 2 and class V for DN 80 and above.

#### Fugitive emissions

High integrity shaft seals give low emission performance, even under thermal cycling.

Tested and approved to Shell MESC SPE 77/312 class A and meets the leakage performance of BS EN ISO 15848-2 class A.

# KTM HINDLE ULTRA-SEAL BALL VALVES

## SERIES 300

### CARBON SEATED DESIGN FEATURES

Incorporating similar design technology to the metal seated range of ball valves, including spring materials and low emission seals.

#### Temperature range

Suitable for a range of service temperatures between -20°C and 300°C for use with clean organic solvents including PTA. Not recommended for fluids carrying abrasive particles. Heat dissipation bonnets are available for gland isolation outside lagging area.

#### Seat design

Carbon graphite seats are assembled into seat holders by thermal control fitting. This ensures correct support for the seat material throughout the service conditions.

#### Seat leakage

The live loaded seat design gives reliable tight shut off in both directions to BS ISO 5208 rate A.

#### Fugitive emissions

High integrity shaft seals give low emission performance, even under thermal cycling. Tested to Shell MESC SPE 77/312 class A and meets the leakage performance of BS EN ISO 15848-2 class A.

### CRYOGENIC SERVICE DESIGN FEATURES

KTM Hindle ball valves are recognized leaders in the field of low temperature and cryogenic applications, with more than twenty years experience in this specialized market sector. KTM Hindle experience includes many substantial international contracts for low temperature and cryogenic valves, including several large projects on liquefied natural gas (LNG) plants, for major users and engineering contractors world-wide.

Ultra-Seal cryogenic ball valves are type approval tested by Shell GSI & listed on Shell TAMAP database.

#### Extensions

A one-piece extension bonnet is fitted so as to relocate the shaft seal away from the cold area and to provide a pressurized column within which the cold liquid phase is changed, by heat transfer with the environment, to the gaseous phase. The extension also allows for the insulation of the valve body. KTM Hindle offer two extension lengths for each size of valve, in accordance with Shell specifications.

#### Cavity relief

For temperatures below -50°C a pressure equalizing hole is provided in the ball at the upstream (sleeve end) of the valve, to provide positive cavity relief. This renders the valve uni-directional and the body is marked accordingly.

#### Operating torque

Low temperature service requires higher operating torque and gearboxes may be required to replace lever operators. Since temperature is only one of the factors affecting operating torque, customers are advised to provide full application details with enquiries.

#### Drip collars

Customers may specify the fitting of drip collars/trays, which minimize ice accumulation on the extension and prevent possible damage to lagging.

#### Acceptance testing

Dedicated in-house test facilities enable valves to be performance tested, at cryogenic temperatures, in accordance with major international standards or customer's individual requirements.

### EXTENSION BONNET LENGTHS

Valve size			Extension length			
			-30°C to -109°C		-110°C to -196°C	
DN	NPS	Class	inch	mm	inch	mm
15 - 20	½ - ¾	150	4	100	8	200
		300	4	100	8	200
25 - 50	1 - 2	150	5	125	10	250
		300	5	125	10	250
80 - 100	3 - 4	150	6	150	12	300
		300	6	150	12	300
150 - 200	6 - 8	150	7	175	14	350
100 - 200	4 - 8	300	7	175	14	350

# KTM HINDLE ULTRA-SEAL BALL VALVES

## SERIES 300

PARTS IDENTIFICATION SERIES 300 – FULL BORE SOFT SEATED

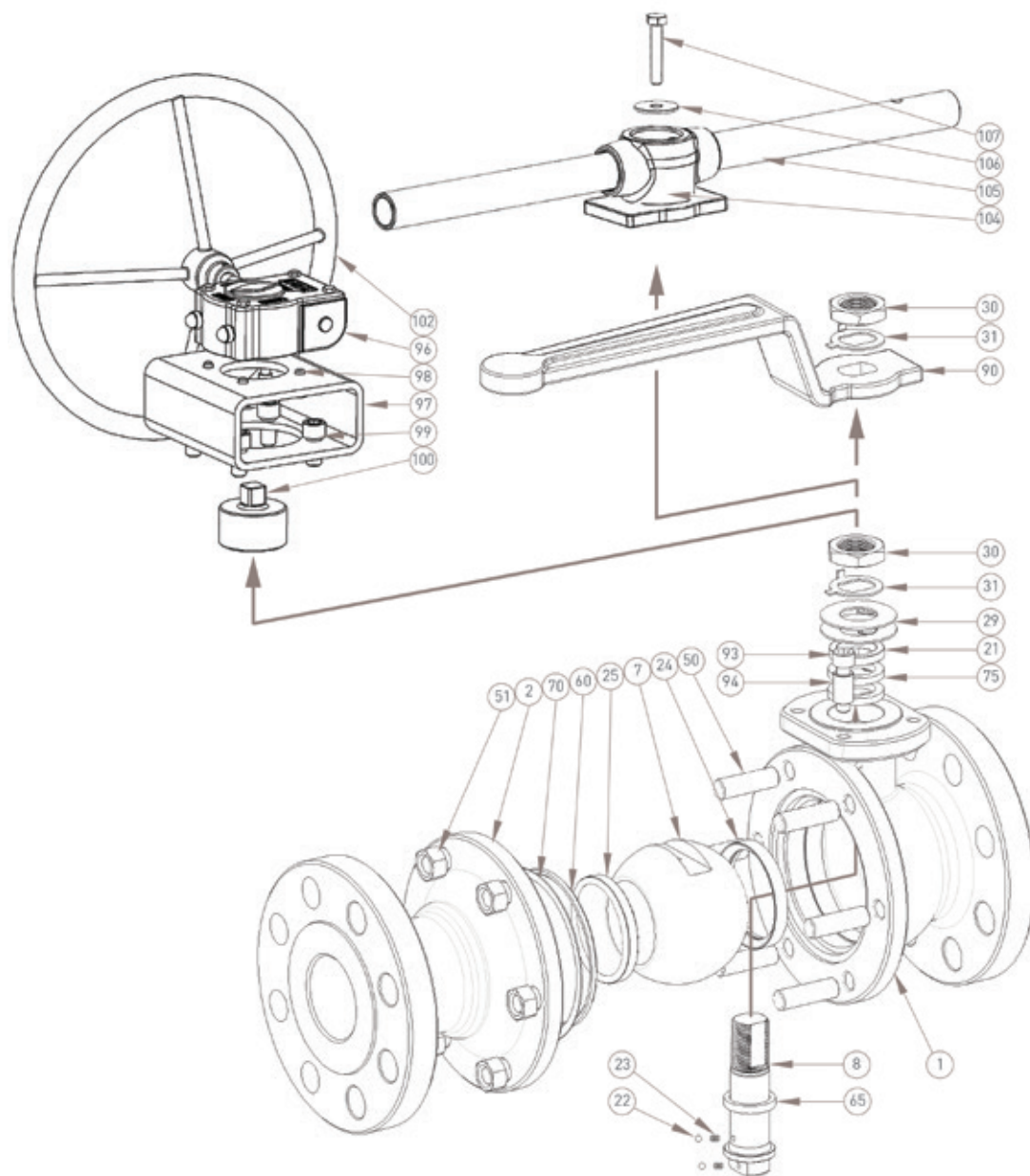

### PARTS LIST

Item	Component	Item	Component	Item	Component
1	Body	31	Tab washer	97	Mounting bracket
2	Connector	50	Body studbolt	98	Gearbox screw
7	Ball	51	Body nut	99	Bracket screw
8	Shaft	60	Body primary seal	100	Coupling
21	Gland collar	65	Shaft primary seal	102	Handwheel
22	Shaft anti-static ball	70	Body fire seal	104	T-Bar adaptor
23	Shaft anti-static spring	75	Shaft fire seal	105	T-Bar tube
24	Body seat	90	Handlever	106	T-Bar washer
25	Connector seat	93	Stop screw	107	T-Bar screw
29	Gland spring	94	Stop collar		
30	Shaft nut	96	Gearbox		

### NOTES

1. Standard materials of construction are given on page 10.

# KTM HINDLE ULTRA-SEAL BALL VALVES

## SERIES 300

PARTS IDENTIFICATION SERIES 300 – FULL BORE METAL / CARBON SEATED

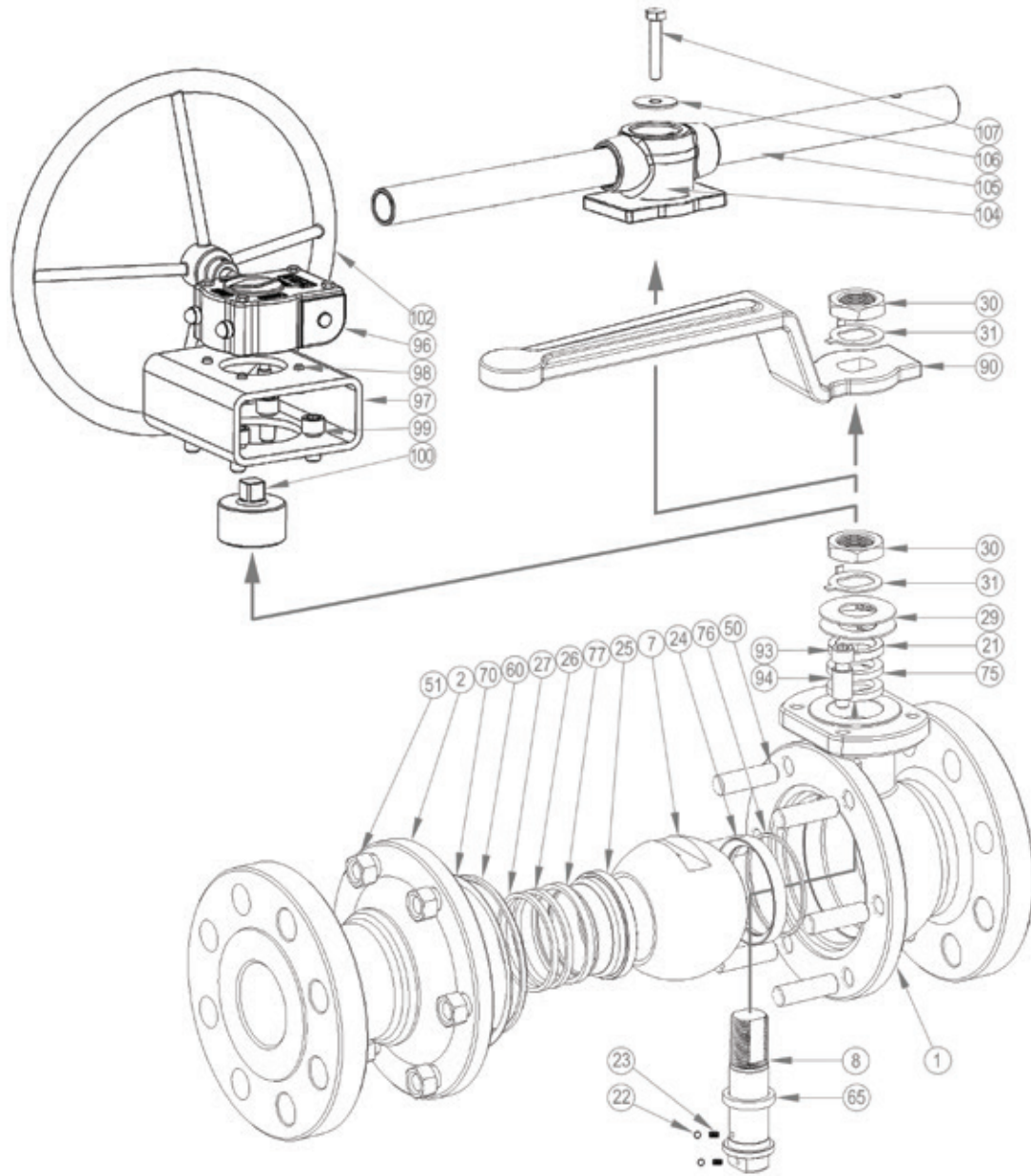

### PARTS LIST

Item	Component	Item	Component	Item	Component
1	Body	30	Shaft nut	93	Stop screw
2	Connector	31	Tab washer	94	Stop collar
7	Ball	50	Body studbolt	96	Gearbox
8	Shaft	51	Body nut	97	Mounting bracket
21	Gland collar	60	Body primary seal	98	Gearbox screw
22	Shaft anti-static ball	65	Shaft primary seal	99	Bracket screw
23	Shaft anti-static spring	75	Shaft fire seal	100	Coupling
24	Body seat	76	Body seat seal	102	Handwheel
25	Connector seat	77	Connector seat seal	104	T-Bar adaptor
26	Seat energizer	90	Handlever	105	T-Bar tube
27	Seat spring	91	Handlever washer	106	T-Bar washer
29	Gland spring	92	Handlever screw	107	T-Bar screw

### NOTES

- Standard materials of construction are given on page 10.
- Heat dissipation bonnets available for gland isolation outside lagging areas.

# KTM HINDLE ULTRA-SEAL BALL VALVES

## SERIES 300

### DIMENSIONS SERIES 300 – FULL BORE SOFT SEATED

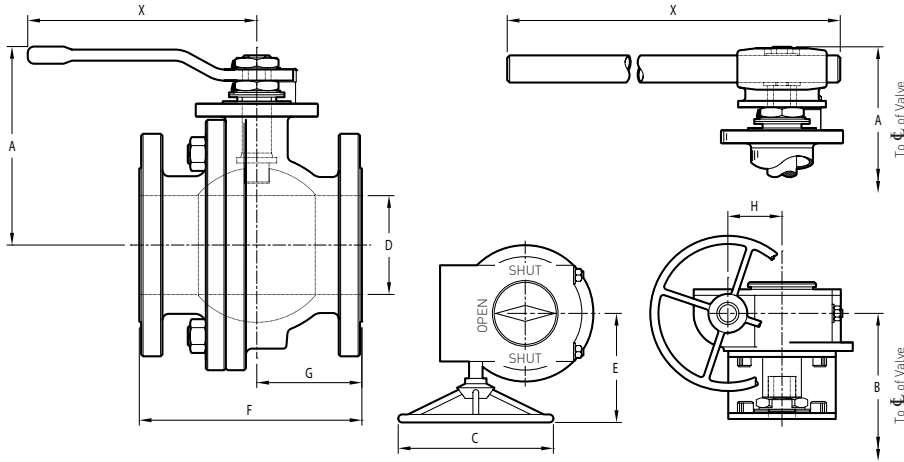

#### CLASS 150 - MODEL 315F

Size		A		B		C		D		E		F		G		H		X		Weight
NPS	DN	in.	mm	in.	mm	in.	mm	in.	mm	in.	mm	in.	mm	in.	mm	in.	mm	in.	mm	kg
1/2	15	4 <sup>7</sup> / <sub>32</sub>	107.2	-	-	-	-	1/2	12.7	-	-	4 <sup>1</sup> / <sub>4</sub>	108.0	1 <sup>3</sup> / <sub>4</sub>	44.5	-	-	6 <sup>1</sup> / <sub>4</sub>	158.8	2.1
3/4	20	4 <sup>1</sup> / <sub>2</sub>	114.3	-	-	-	-	3/4	19.1	-	-	4 <sup>5</sup> / <sub>8</sub>	117.5	2	50.8	-	-	6 <sup>1</sup> / <sub>4</sub>	158.8	3.2
1	25	4 <sup>11</sup> / <sub>16</sub>	119.1	-	-	-	-	1	25.4	-	-	5	127.0	2	50.8	-	-	6 <sup>1</sup> / <sub>4</sub>	158.8	4.0
1 1/2	40	5 <sup>5</sup> / <sub>16</sub>	141.3	-	-	-	-	1 1/2	38.1	-	-	6 1/2	165.1	2 5/8	67.5	-	-	7 11/16	195.3	7.4
2	50	7 1/16	179.4	-	-	-	-	2	50.8	-	-	7	177.8	3	76.2	-	-	10 3/8	263.5	12.9
3	80	8 7/8	205.9	-	-	-	-	3	76.2	-	-	8	203.2	3 3/4	95.3	-	-	20	508.0	27.3
4	100	8 11/16	220.1	-	-	-	-	4	101.6	-	-	9	228.6	4 1/4	108.0	-	-	20	508.0	42.5
6	150	11 3/16	284.5	-	-	-	-	6	152.4	-	-	10 1/2	266.7	5 1/4	133.4	-	-	26 1/2	673.1	80.2
8	200	-	-	17 11/16	448.5	7.87	200	8	203.2	11 5/16	288	18	457.2	8	203.2	2.8	71	-	-	125.0

#### CLASS 300 - MODEL 330F

Size		A		B		C		D		E		F		G		H		X		Weight
NPS	DN	in.	mm	in.	mm	in.	mm	in.	mm	in.	mm	in.	mm	in.	mm	in.	mm	in.	mm	kg
1/2	15	4 <sup>7</sup> / <sub>32</sub>	107.2	-	-	-	-	1/2	12.7	-	-	5 1/2	139.7	1 7/8	47.6	-	-	6 1/4	158.8	2.6
3/4	20	4 1/2	114.3	-	-	-	-	3/4	19.1	-	-	6	152.4	2 1/4	57.2	-	-	6 1/4	158.8	4.3
1	25	4 <sup>11</sup> / <sub>16</sub>	119.1	-	-	-	-	1	25.4	-	-	6 1/2	165.1	2 5/8	66.7	-	-	6 1/4	158.8	5.8
1 1/2	40	5 <sup>5</sup> / <sub>16</sub>	141.3	-	-	-	-	1 1/2	38.1	-	-	7 1/2	190.5	2 5/8	66.7	-	-	7 11/16	195.3	10.7
2	50	7 1/16	179.4	-	-	-	-	2	50.8	-	-	8 1/2	215.9	3	76.2	-	-	10 3/8	263.5	15.8
3	80	8 7/8	205.9	-	-	-	-	3	76.2	-	-	11 1/8	282.6	3 3/4	95.3	-	-	20	508.0	36.3
4	100	8 11/16	220.1	-	-	-	-	4	101.6	-	-	12	304.8	6	152.0	-	-	20	508.0	53.5
6	150	-	-	-	-	15 3/4	400	6	152.4	10 <sup>15</sup> / <sub>16</sub>	278	15 7/8	403.2	5 5/8	142.9	2.8	71	-	-	122.0
8	200	-	-	17 3/4	450.8	23 3/8	600	8	203.2	12	305	16 1/2	419.1	8	203.2	3.4	86	-	-	175.0

#### NOTES

Series 300 Soft seat

Size range: Class 150/300 NPS 1/2 - 8 (DN 15 - 200)

1. The type of operator supplied, as standard, for each size of valve is given on page 2.
2. Face to face dimensions (F in table) conform to ASME B16.10 and BS EN 558. Details of standard patterns are given on page 3.
3. Top mounting flange details are given on page 9.
4. Flange dimensions conform to ASME B16.5.



# KTM HINDLE ULTRA-SEAL BALL VALVES

## SERIES 300

### DIMENSIONS SERIES 300 - FULL BORE METAL/CARBON SEATED

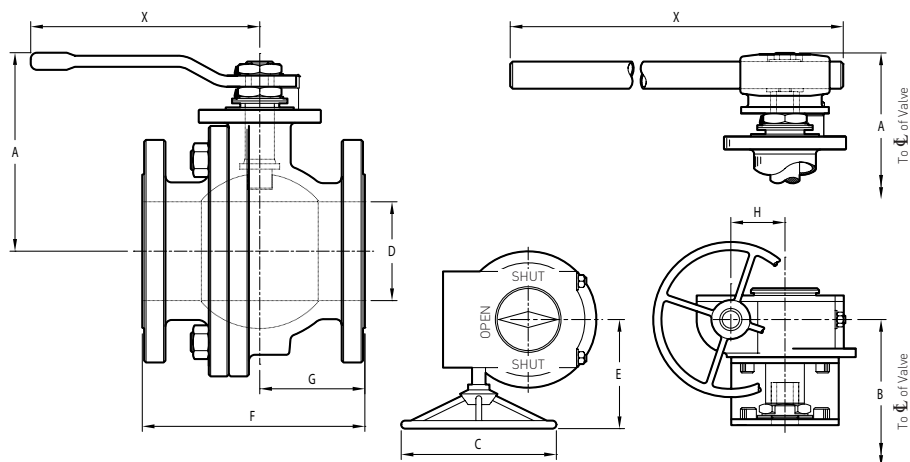

#### CLASS 150 – MODEL 315FM / 315FC

Size		A		B		C		D		E		F		G		H		X		Weight
NPS	DN	in.	mm	in.	mm	in.	mm	in.	mm	in.	mm	in.	mm	in.	mm	in.	mm	in.	mm	kg
1/2	15	4 <sup>7</sup> / <sub>32</sub>	107.2	-	-	-	-	1/2	12.7	-	-	4 <sup>1</sup> / <sub>4</sub>	108.0	1 <sup>3</sup> / <sub>4</sub>	44.5	-	-	6 <sup>1</sup> / <sub>4</sub>	158.8	2.1
3/4	20	4 <sup>1</sup> / <sub>2</sub>	114.3	-	-	-	-	3/4	19.1	-	-	4 <sup>5</sup> / <sub>8</sub>	117.5	2	50.8	-	-	6 <sup>1</sup> / <sub>4</sub>	158.8	3.2
1	25	4 <sup>11</sup> / <sub>16</sub>	119.1	-	-	-	-	1	25.4	-	-	5	127.0	2	50.8	-	-	6 <sup>1</sup> / <sub>4</sub>	158.8	4.0
1 1/2	40	5 <sup>5</sup> / <sub>16</sub>	141.3	-	-	-	-	1 1/2	38.1	-	-	6 <sup>1</sup> / <sub>2</sub>	165.1	2 <sup>5</sup> / <sub>8</sub>	67.5	-	-	7 <sup>11</sup> / <sub>16</sub>	195.3	7.4
2	50	7 <sup>1</sup> / <sub>16</sub>	179.4	-	-	-	-	2	50.8	-	-	7	177.8	3	76.2	-	-	10 <sup>5</sup> / <sub>8</sub>	263.5	12.9
3	80	8 <sup>7</sup> / <sub>8</sub>	205.9	-	-	-	-	3	76.2	-	-	8	203.2	3 <sup>3</sup> / <sub>4</sub>	95.3	-	-	20	508.0	27.3
4	100	-	-	10 <sup>1</sup> / <sub>2</sub>	266.7	15 <sup>3</sup> / <sub>4</sub>	400	4	101.6	10 <sup>15</sup> / <sub>16</sub>	278	9	228.6	4 <sup>1</sup> / <sub>4</sub>	108.0	2.8	71	-	-	52.5
6	150	-	-	12 <sup>5</sup> / <sub>16</sub>	313	29 <sup>1</sup> / <sub>2</sub>	750	6	152.4	12	305	10 <sup>1</sup> / <sub>2</sub>	266.7	5 <sup>1</sup> / <sub>4</sub>	133.4	3.4	86	-	-	95.2

#### CLASS 300 – MODEL 330FM / 330FC

Size		A		B		C		D		E		F		G		H		X		Weight
NPS	DN	in.	mm	in.	mm	in.	mm	in.	mm	in.	mm	in.	mm	in.	mm	in.	mm	in.	mm	kg
1/2	15	4 <sup>7</sup> / <sub>32</sub>	107.2	-	-	-	-	1/2	12.7	-	-	5 <sup>1</sup> / <sub>2</sub>	139.7	1 <sup>7</sup> / <sub>8</sub>	47.6	-	-	6 <sup>1</sup> / <sub>4</sub>	158.8	2.6
3/4	20	4 <sup>1</sup> / <sub>2</sub>	114.3	-	-	-	-	3/4	19.1	-	-	6	152.4	2 <sup>1</sup> / <sub>4</sub>	57.2	-	-	6 <sup>1</sup> / <sub>4</sub>	158.8	4.3
1	25	4 <sup>11</sup> / <sub>16</sub>	119.1	-	-	-	-	1	25.4	-	-	6 <sup>1</sup> / <sub>2</sub>	165.1	2 <sup>5</sup> / <sub>8</sub>	66.7	-	-	6 <sup>1</sup> / <sub>4</sub>	158.8	5.8
1 1/2	40	5 <sup>5</sup> / <sub>16</sub>	141.3	-	-	-	-	1 1/2	38.1	-	-	7 <sup>1</sup> / <sub>2</sub>	190.5	2 <sup>5</sup> / <sub>8</sub>	66.7	-	-	7 <sup>11</sup> / <sub>16</sub>	195.3	10.7
2	50	7 <sup>1</sup> / <sub>16</sub>	179.4	-	-	-	-	2	50.8	-	-	8 <sup>1</sup> / <sub>2</sub>	215.9	3	76.2	-	-	10 <sup>5</sup> / <sub>8</sub>	263.5	15.8
3	80	-	-	9 <sup>7</sup> / <sub>8</sub>	250.8	11 <sup>13</sup> / <sub>16</sub>	300	3	76.2	10	254	11 <sup>1</sup> / <sub>8</sub>	282.6	3 <sup>3</sup> / <sub>4</sub>	95.3	2.8	71	-	-	46.3
4	100	-	-	10 <sup>1</sup> / <sub>2</sub>	266.7	19 <sup>11</sup> / <sub>16</sub>	500	4	101.6	11 <sup>5</sup> / <sub>16</sub>	288	12	304.8	6	152.0	2.8	71	-	-	122.0
6	150	-	-	12 <sup>5</sup> / <sub>16</sub>	313.0	23 <sup>5</sup> / <sub>8</sub>	600	6	152.4	15 <sup>1</sup> / <sub>4</sub>	387	15 <sup>5</sup> / <sub>8</sub>	403.2	5 <sup>5</sup> / <sub>8</sub>	142.9	5.1	130	-	-	175.0

#### NOTES

Series 300 Metal/Carbon seat

Size range: Class 150/300 NPS 1/2 - 6 [DN 15 - 150]

1. The type of operator supplied as standard for each size of valve is given on page 2.
2. Face to face dimensions (F in table) conform to ASME B16.10 and BS EN 558. Details of standard patterns are given on page 3.
3. Top mounting flange details are given on page 9.
4. Flange dimensions conform to ASME B16.5.



# KTM HINDLE ULTRA-SEAL BALL VALVES

## SERIES 300

### TOPWORKS DIMENSIONS

Valve size			A		B		C		D		E		F		G
DN	NPS	ISO flange type	mm	inch	mm	inch	mm	inch	mm	inch	mm	inch	mm		
15	1/2	F03	M12 x 1.25	0.787	20	0.315	8.00	0.437	11.00	0.078	2.0	0.984	25.00	M5	
						0.313	7.92					0.974	24.75		
20	3/4	F04	M14 x 1.25	0.984	25	0.374	9.50	0.600	15.25	0.078	2.0	1.181	30.00	M5	
						0.372	9.45					1.171	29.75		
25	1	F04	M14 x 1.25	0.984	25	0.374	9.50	0.600	15.25	0.078	2.0	1.181	30.00	M5	
						0.372	9.45					1.171	29.75		
40	1 1/2	F05	M18 x 1.5	1.300	33	0.472	12.00	0.787	20.00	0.060	1.5	1.378	35.00	M6	
						0.470	11.95					1.368	34.75		
50	2	F07	M22 x 1.5	1.338	34	0.590	15.00	0.837	21.25	0.060	1.5	2.171	55.00	M8	
						0.588	14.95					2.161	54.75		
80	3	F10	M28 x 1.5	1.650	42	0.748	19.00	1.075	27.30	0.090	2.3	2.760	70.00	M10	
						0.746	18.95					2.750	69.75		
100	4	F10	M28 x 1.5	1.650	42	0.748	19.00	1.075	27.30	0.090	2.3	2.760	70.00	M10	
						0.746	18.95					2.750	69.75		
150	6	F12	M36 x 1.5	2.200	56	0.945	24.00	1.400	35.60	0.090	2.3	3.345	85.00	M12	
						0.945	23.95					3.335	84.75		
200	8	F16	M60 x 1.5	3.386	86	1.813	46.00	2.165	55.00	0.090	2.3	5.123	130.00	M20	
						1.810	45.95					5.113	129.75		

### TOPWORKS DIMENSIONS

Valve size			H		J		K		L		N	
DN	NPS	ISO flange type	inch	mm	inch	mm	inch	mm	inch	mm	inch	mm
15	1/2	F03	0.250	6.35	1.417	36.0	1.142	29.0	1.875	47.6	1.375	34.9
20	3/4	F04	0.315	8.00	1.654	42.0	1.322	33.6	2.125	54.0	1.560	39.6
25	1	F04	0.315	8.00	1.654	42.0	1.516	38.5	2.125	54.0	1.750	44.5
40	1 1/2	F05	0.315	8.00	1.969	50.0	2.258	57.3	2.500	63.5	1.875	47.6
50	2	F07	0.503	12.75	2.756	70.0	3.818	97.0	3.563	90.5	2.750	69.9
80	3	F10	0.535	13.60	4.016	102.0	5.097	129.5	4.938	125.4	3.875	98.4
100	4	F10	0.535	13.60	4.016	102.0	5.723	145.4	4.938	125.4	4.938	125.4
150	6	F12	0.723	18.35	4.921	125.0	7.535	191.4	6.000	152.4	6.000	152.4
200	8	F16	1.000	25.40	6.496	165.0	10.16	258.0	8.250	209.6	8.250	209.6

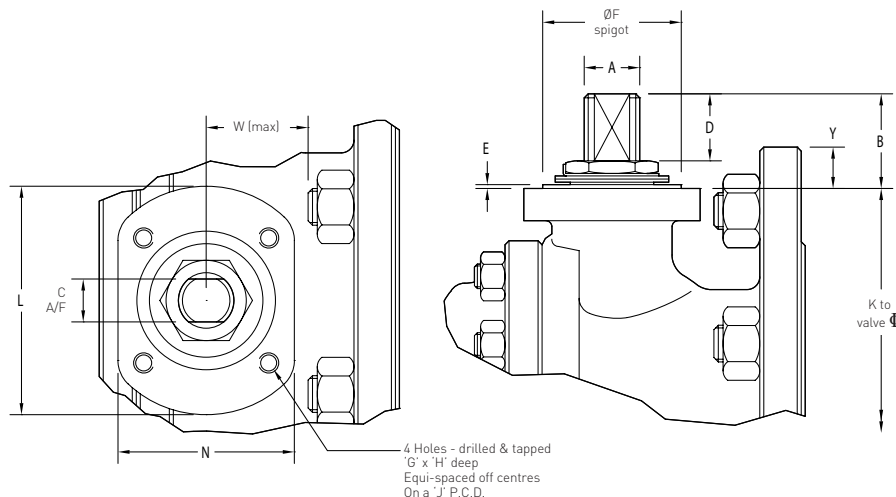

### NOTES

- Dimensions Y and Z are only applicable when height of the mounting flange falls below top of flange [as shown]. Only these valve sizes are affected. Dimension W is based on bolting to ASME B18.2.2 heavy hex nuts.

### DIMENSIONS

Valve size			Y		W	
DN	NPS	Type	inch	mm	inch	mm
15	1/2	315	0.608	15.4	0.649	16.5
15	1/2	330	0.733	18.6	0.721	18.3
20	3/4	315	0.616	15.7	0.783	19.9
20	3/4	330	0.991	25.2	0.814	20.7
25	1	315	0.609	15.5	0.975	24.8
25	1	330	0.922	23.4	1.051	26.7
40	1 1/2	315	0.248	6.3	1.438	36.5
40	1 1/2	330	0.811	20.6	0.885	22.5

# KTM HINDLE ULTRA-SEAL BALL VALVES

## SERIES 300

### PRINCIPAL COMPONENTS

No.	Component	Carbon steel valves	Stainless steel valves
1	Body	ASTM A216 WCB <sup>[1]</sup>	ASTM A351 CF8M
2	Connector	ASTM A216 WCB <sup>[1]</sup>	ASTM A351 CF8M
7	Ball <sup>[3][4]</sup>	316 / 316L Stainless steel	316 / 316L Stainless steel
7	Ball <sup>[5]</sup>	AISI 316Ti (with hard metal alloy coating)	AISI 316Ti (with hard metal alloy coating)
8	Shaft	316 / 316L Stainless steel	316 / 316L Stainless steel
8	Shaft <sup>[4][5]</sup>	17-4 PH	17-4 PH (alternative XM19)
21	Gland collar	316 / 316L Stainless steel	316 / 316L Stainless steel
24/25	Seat ring <sup>[3]</sup>	Virgin PTFE	Virgin PTFE
24/25	Seat ring <sup>[4]</sup>	316 / 316L Stainless steel (with carbon insert)	316 / 316L Stainless steel (with carbon insert)
24/25	Seat ring <sup>[5]</sup>	AISI 316Ti (with hard metal alloy coating)	AISI 316Ti (with hard metal alloy coating)
50	Body studbolt	ASTM A193-B7	ASTM A193-B8
51	Body nut	ASTM A194-2H	ASTM A 194-8

### OTHER COMPONENTS

Materials which are common for both carbon steel and stainless steel valves

No.	Component	Material
22	Anti-static ball	ASTM A276-316
23	Anti-static spring	ASTM B164 MONEL 400
26	Connector seat energizer <sup>[4][5]</sup>	ASTM A276-316 / 316L
27	Seat spring	ASTM A313-631 17-7 PH (up to 350°C) / Alloy A 286 (up to 450°C)
29	Gland spring	17-7 PH Stainless steel (up to 350°C) Inconel (above 350°C)
30	Shaft nut	ASTM A240-304H
31	Tab washer	ASTM A240-304H
60	Body primary seal <sup>[3]</sup>	PTFE
60	Body primary seal <sup>[4][5]</sup>	Flexible graphite
65	Shaft primary seal	25% GF PTFE <sup>[3]</sup> , flexible graphite <sup>[4][5]</sup>
70	Body fire seal <sup>[3]</sup>	PTFE
70	Body fire seal <sup>[4][5]</sup>	Flexible graphite
75	Shaft fire seal	Flexible graphite
76	Body seat seal <sup>[4][5]</sup>	Flexible graphite
77	Connector seat seal <sup>[4][5]</sup>	Flexible graphite
90	Handlever <sup>[2]</sup>	ASTM A276-304
93	Stop collar screw <sup>[2]</sup>	A2-70
94	Stop collar	Brass, nickel plated
96	Gearbox <sup>[2]</sup>	Commercial
97	Mounting bracket <sup>[2]</sup>	Stainless steel
98	Gearbox screw <sup>[2]</sup>	A2-70
99	Bracket screw <sup>[2]</sup>	A2-70
100	Coupling <sup>[2]</sup>	Stainless steel
102	Handwheel <sup>[2]</sup>	Carbon steel
104	T-Bar adapter <sup>[2]</sup>	ASTM A351 CF8M
105	T-Bar tube <sup>[2]</sup>	ASTM A573-70
106	T-Bar washer <sup>[2]</sup>	ASTM A240-304H
107	T-Bar screw <sup>[2]</sup>	A2-70

### ALTERNATIVE MATERIALS

Body and trim
Low carbon steel - LCC
Duplex stainless steel
Aluminium bronze
Monel
Other materials available on request.

### Seats

Reinforced PTFE
Carbon filled PTFE
TFM 1600
Carbon graphite filled PEEK™

### ACCESSORIES

Actuation controls
Locking devices
Lagging extensions

### NOTES

1. Max. carbon content 0.25%.
  2. Operator type varies by size (see pages 2).
  3. Soft seated valves.
  4. Carbon seated valves.
  5. Metal seated valves.
- Certification is available on standard production, as follows:
- hydrostatic body and seat test.
  - pneumatic seat test.
  - material (chemical and physical) to BS EN 10204 - 3.1.

# KTM HINDLE ULTRA-SEAL BALL VALVES

## SERIES 300

### PRINCIPAL COMPONENTS

Coating type	Description	Coating thickness	Coating hardness	Temp. limit
HTN-60	Nickel alloy coating	500 micron	60 HRc	450°C
	Flame spraying and fusing			
HTC-70	Chromium carbide coating	200 micron	70 HRc	450°C
	HVOF spray			
HTT-75	Tungsten carbide coating	200 micron	75 HRc approx.	350°C
	HVOF spray			

### CARBON GRAPHITE MATERIAL

Carbon graphite type	Description	Density	Coefficient of thermal expansion	Temp. limit
HTCG	Hard carbon graphite A strong antimony impregnated carbon graphite. Suitable for clean organic solvents and purified terephthalic acid (PTA).	2.50 x 10 <sup>3</sup> kg.m <sup>-3</sup>	4.7 x 10 <sup>-6</sup> °C	300°C

### STANDARD PAINT/FINISH

#### Carbon steel valves

Red oxide primer

#### Stainless steel valves

Castings are acid pickled and passivated to remove surface impurities.

#### Paint finishes

A range of painting specifications for offshore and onshore service conditions are available to customer requirements.

### GRAPH LINE IDENTIFICATION

Size	Seat material	
	PTFE	RTFE
NPS ½ - 2 DN 15 - 50	B	A
NPS 3 - 6 DN 80 - 150	C	A
NPS 8 DN 200	D	C

### PRESSURE/TEMPERATURE GRAPH

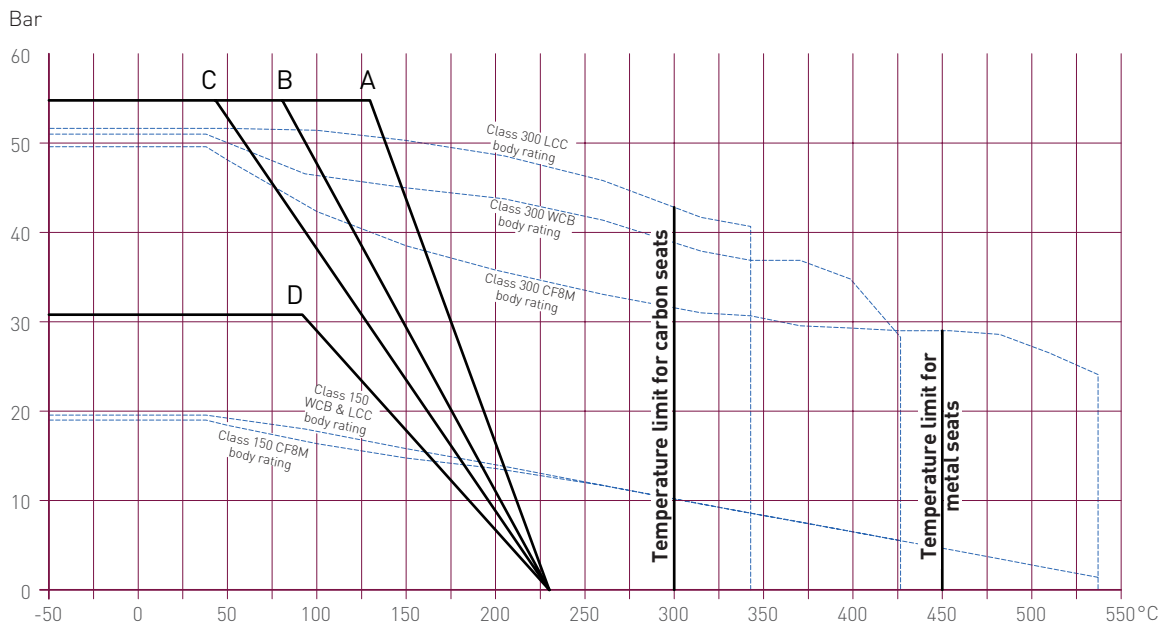

### NOTES

1. The maximum working capability of any given valve is either the body rating or seat rating, whichever is the lower.
2. The graph line Identification table indicates the valve seat materials represented by lines A to D on the graph.
3. For metal & carbon seats use the maximum body ratings. Carbon seats can only achieve 300°C max.

# KTM HINDLE ULTRA-SEAL BALL VALVES

## SERIES 300

### C<sub>v</sub>/K<sub>v</sub> - VALUES

Valve size		Class 150		Class 300	
NPS	DN	C <sub>v</sub>	K <sub>v</sub>	C <sub>v</sub>	K <sub>v</sub>
1/2	15	20	17	17	15
3/4	20	34	29	34	29
1	25	140	121	132	114
1 1/2	40	281	243	265	229
2	50	511	442	470	407
3	80	1380	1194	1200	1038
4	100	2200	1903	2210	1912
6	150	5400	4671	5400	4671
8	200	10660	9221	10660	9221

### NOTES

- Flow coefficients are for valves in the fully open position.
- Ultra-Seal ball valve models are categorised by a four part code indicating design type, ball and seat, flange drilling and body material to show example given (315FM-15-316).
- Other flange drillings available on request.
- Trim and other component materials for standard valves are given on page 10.

### VALVE CODING SYSTEM

Individual model numbers are derived from a combination of:

- Design series number (300)
- Design pressure class (150, 300)
- Ball and seat design (F, FM, FC)
- Flange drilling (ASME 150, 300)
- Body material (161, 316)

### SELECTION GUIDE

Example:	3	15	FM	15	316
<b>Series</b>					
<b>3</b>	300				
<b>Class</b>					
<b>15</b>	150				
<b>30</b>	300				
<b>Ball/seat design</b>					
<b>F</b>	Full bore soft				
<b>FM</b>	Full bore metal				
<b>FC</b>	Full bore carbon seats				
<b>Flange drilling</b>					
<b>15</b>	ASME 150				
<b>30</b>	ASME 300				
<b>Body material</b>					
<b>316</b>	Stainless steel ASTM A351 CF8M				
<b>161</b>	Carbon steel ASTM A216 WCB				
<b>LCC</b>	Carbon steel ASTM A352 LCC				
<b>AB2</b>	Aluminium bronze BS1400 AB2				
<b>DUP</b>	Duplex stainless steels				