

Types ACE95 and ACE95Sr Tank Blanketing Valves

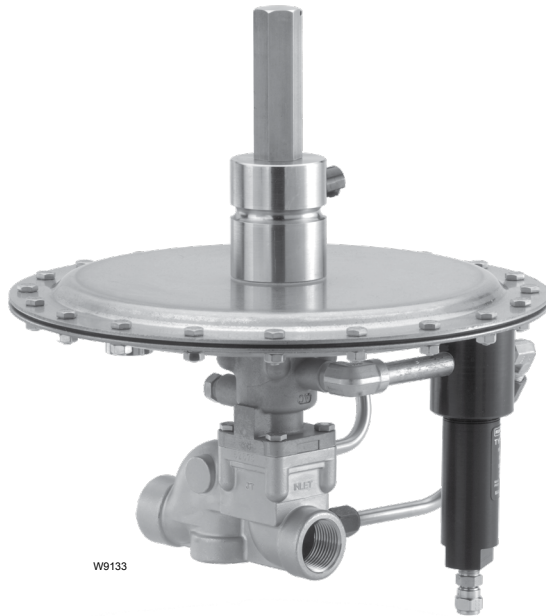

Figure 1. Type ACE95 Tank Blanketing Valve

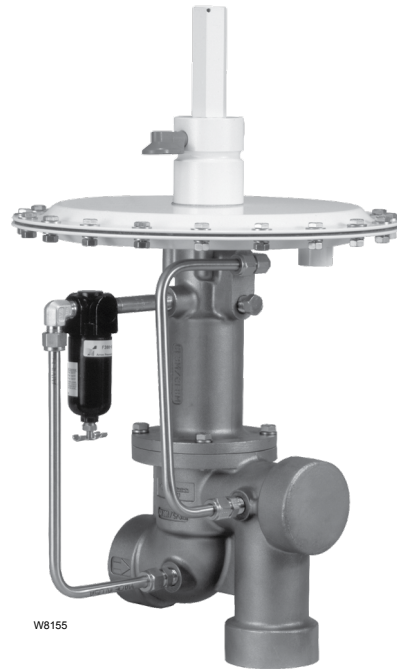

Figure 2. Type ACE95Sr Tank Blanketing Valve

Features

- Fully Balanced Pilot Design
Reduces Inlet Pressure Sensitivity
- Frictionless Pilot Valve
- Bubble Tight Shutoff
- Pilot Controlled
- Angled or In-Line Body Option
- Self-Contained
- Highly Sensitive
- Diagnostics Available
- Vacuum Settings Available
- Stainless Steel
Construction Available

Bulletin 74.1:ACE95

Specifications

The Specifications section lists the specifications for Types ACE95 and ACE95Sr Tank Blanketing Valves. Factory specification is stamped on the nameplate fastened on the valve at the factory.

Sizes and End Connection Styles

Type ACE95

Angled Body⁽¹⁾:

3/4 NPT

1 NPT

NPS 1 / DN 25, CL150 RF

NPS 1 / DN 25, CL300 RF

NPS 1 / DN 25, PN 16/25/40 RF

NPS 1 / DN 25, Sanitary Flange

In-Line Body:

3/4 NPT

1 NPT

NPS 1 / DN 25, CL150 RF

NPS 1 / DN 25, CL300 RF

NPS 1 / DN 25, PN 16/25/40 RF

NPS 1 x 2 / DN 25 x 50, CL150 RF

NPS 1 x 2 / DN 25 x 50, PN 16/25/40 RF

NPS 1 / DN 25, Sanitary Flange

Type ACE95Sr

Angled Body⁽¹⁾:

2 NPT

NPS 2 / DN 50, CL150 RF

NPS 2 / DN 50, CL300 RF

Maximum Operating Inlet Pressure⁽²⁾

200 psig / 13.8 bar

Maximum Emergency Outlet (Casing) Pressure⁽²⁾

20 psig / 1.4 bar

Maximum Operating Outlet Pressure⁽²⁾

1.5 psig / 0.10 bar

Outlet Pressure Ranges

-5 in. w.c. to 1.5 psig / -12 to 0.10 bar

Minimum and Maximum Differential Pressures⁽²⁾

Minimum: 25 psi / 1.7 bar

Maximum: Up to 200 psi / 13.8 bar depending on main valve spring (See Table 6)

Main Valve Flow Characteristic

Linear

Pressure Registration

External

Accuracy

Typically within 0.5 in. w.c. / 1 mbar when flowing 5 to 70 percent of advertised capacities

Temperature Capabilities⁽²⁾

Nitrile (NBR): -20 to 180°F / -29 to 82°C

Fluorocarbon (FKM): 0 to 212°F / -18 to 100°C

Ethylene propylene (EPDM - FDA):

-20 to 212°F / -29 to 100°C

Perfluoroelastomer (FFKM):

-20 to 212°F / -29 to 100°C

IEC Sizing Coefficients

Type ACE95⁽³⁾:

X_T: 0.72

F_D: 0.40

F_L: 0.89

K_m: 0.79

Type ACE95Sr:

X_T: 0.72

F_D: 0.46

F_L: 0.89

K_m: 0.79

Flow Coefficients for Relief Valve Sizing

Type ACE95:

C_v 1 use C_v 1.1

C_v 2 use C_v 2.2

C_v 4 use C_v 4.4

C_v 7.5 use C_v 9.25

C_v 10 use C_v 11

Type ACE95Sr:

C_v 20 use C_v 22

C_v 45 use C_v 50

C_v 60 use C_v 66

Construction Materials

Body: CF3M/CF8M Stainless steel

Trim: 304 Stainless steel and 316 Stainless steel

Elastomers: Nitrile (NBR), Fluorocarbon (FKM), FDA-Ethylene propylene (FDA-EPDM) or Perfluoroelastomer (FFKM)

Diaphragm: Fluorinated ethylene propylene (FEP)

Actuator: 316 Stainless steel or Carbon steel

Approximate Weights (with all accessories)

Type ACE95: 40 lbs / 18 kg

Type ACE95Sr: 60 lbs / 27 kg

1. Various Single Array Manifold (SAM) tank connections are also available. Contact your local Sales Office for more information.

2. The pressure/temperature limits in this Bulletin or any applicable standard limitation should not be exceeded.

3. For NPS 1 / DN 25 body size, all trims.

Introduction

Tank blanketing is the process of using a gas, such as nitrogen, to maintain a slightly positive pressure in an enclosed storage tank. Tank blanketing prevents a stored product from vaporizing into the atmosphere, reduces product combustibility and prevents oxidation or contamination of the product by reducing its exposure to air. Tank blanketing is utilized with various products, including: adhesives, pharmaceuticals, pesticides, fertilizers, fuels, inks, photographic chemicals and food additives.

Types ACE95 and ACE95Sr valves are self-contained, fully balanced, pilot-operated and are used for accurate pressure control on tank blanketing systems. These valves help control emissions and provide protection against atmospheric contamination. Types ACE95 and ACE95Sr valves maintain a positive tank pressure which reduces the possibility of tank wall collapse during pump out operations, prevents stored product from vaporizing to atmosphere. The Type ACE95Sr uses an angled body in either a 2 NPT, CL150 RF or CL300 RF and is taller than the Type ACE95.

Features and Benefits

- **Pilot Controlled**—ACE95 Series valves are pilot operated which results in a high degree of accuracy and control.
- **Fully Balanced Pilot**—Eliminates setpoint changes caused by variations in inlet pressure.
- **Large Actuator**—Large actuator diaphragm increases sensitivity to tank pressure changes.
- **Rolling Pilot Diaphragm**—The rolling diaphragm balances the pilot valve and eliminates friction, resulting in extremely accurate control.
- **Diagnostic Port**—Allows field analysis of valve operation, simplifying maintenance and reducing service costs.

Options and Accessories

- **Inlet Pressure Gauge**—Displays pressure of blanketing gas supply to the tank blanketing valve.
- **Control Pressure Gauge**—Low-pressure gauge to measure control pressure (tank pressure).
- **Purge Meter (Rotameter)**—Maintains a small amount of flow through the sensing and/or main line. Prevents corrosive tank vapors from damaging upstream equipment.
- **Pressure Switch**—Allows installation of an alarm system to indicate low or high-pressure on the tank.
- **Outlet Check Valve**—Prevents corrosive gases and vapors from flowing back into the blanketing system through the delivery line.
- **Diagnostic Gauge**—Allows analysis of valve operation in the field, simplifying service and reliability.
- **Single Array Manifold (SAM)**—Provides sense line connection and main valve connection through a single tank nozzle. (Not compatible with In-Line end connection).

Principle of Operation

Types ACE95 and ACE95Sr tank blanketing valves control the vapor space pressure over a stored liquid. When liquid is pumped out of the tank or vapors in the tank condense, the pressure in the tank decreases. Tank pressure is sensed by the large actuator diaphragm. When tank pressure is less than the valve set pressure, spring force moves the actuator diaphragm downward.

When the actuator moves downward, it pushes open the pilot valve which allows loading pressure to flow into the tank. As loading pressure decreases, inlet pressure is able to overcome the force of the main valve spring, opening the main valve. See Figure 3.

When pressure in the tank increases above setpoint, the large actuator diaphragm is pushed upward, allowing the pilot to close. Loading pressure equalizes with inlet pressure closing the main valve.

The pilot valve is balanced (inlet pressure creates equal upward and downward force on these components); therefore, the outlet pressure of the unit is not affected by fluctuating inlet pressure.

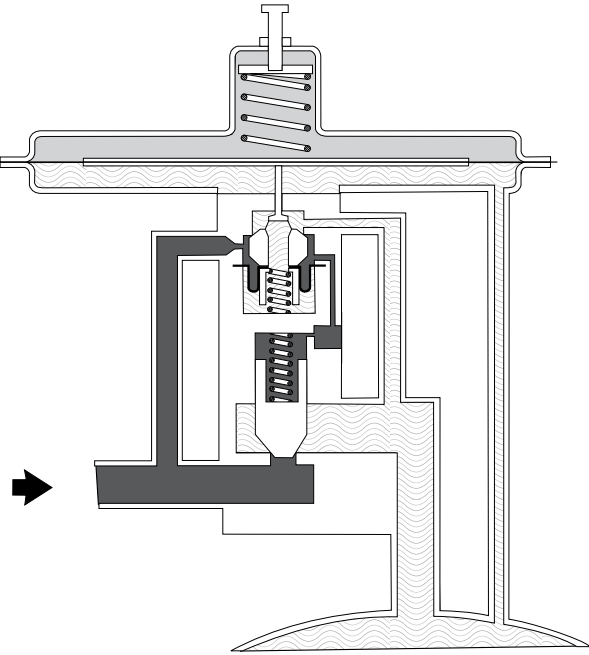

VALVE CLOSED

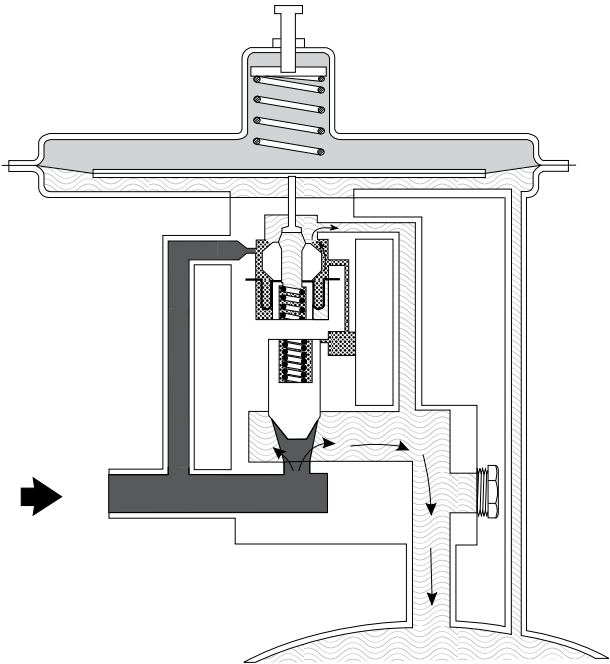

VALVE OPEN

- INLET PRESSURE
- ▨ TANK PRESSURE
- ▩ ATMOSPHERIC PRESSURE
- ▤ INLET BLEED PRESSURE

Figure 3. Type ACE95 Operational Schematic

Diagnostics

Tank blanketing valves are often installed in locations that are difficult to access. Types ACE95 and ACE95Sr valves are available with a diagnostics feature that allows analysis of valve operation in the field, making maintenance easier and more reliable.

The diagnostics feature uses the relationship between pressure in the pilot and main valve chambers to analyze valve performance.

Sizing Methods

Direct Displacement

The direct displacement method should be used with extreme caution. The direct displacement method determines the amount of blanketing gas required to replace liquid pumped out of the tank. Direct displacement does not allow for fluctuating temperature or other factors that may affect pressure in the vapor space. This method is typically applied to tanks operating at constant temperature and containing non-flammable, non-volatile products.

$$Q_{\text{total}} = Q_{\text{pump}}$$

where,

- Q_{total} = Required Flow Rate
- Q_{pump} = Required Flow Rate to replace pumped out liquid from Table 1

API 2000

The American Petroleum Institute Standard 2000 (API 2000) sizing method accounts for liquid pump-out as well as contraction of tank vapors due to cooling. When using API methods:

$$Q_{\text{total}} = Q_{\text{pump}} + Q_{\text{thermal}}$$

where,

- Q_{total} = Required Flow Rate
- Q_{pump} = Required Flow Rate to replace pumped out liquid from Table 1
- Q_{thermal} = Required Flow Rate due to thermal cooling. See Thermal Equations 1 to 4 below or Table 2.

Thermal Equations

For tanks up to 840,000 gallons / 3179 m³ capacity, use one of the following equations:

Equation 1:

$$Q_{\text{thermal}} [\text{SCFH Air}] = V_{\text{tank}} \times 0.0238$$

Equation 2:

$$Q_{\text{thermal}} [\text{SCFH Nitrogen}] = V_{\text{tank}} \times 0.0238 \times 1.015$$

Equation 3:

$$Q_{\text{thermal}} [\text{Nm}^3/\text{h Air}] = V_{\text{tank}} \times 0.169$$

Equation 4:

$$Q_{\text{thermal}} [\text{Nm}^3/\text{h Nitrogen}] = V_{\text{tank}} \times 0.169 \times 1.015$$

where,

- For Equations 1 and 2: V_{tank} = tank volume, gallons
- For Equations 3 and 4: V_{tank} = tank volume, m³

For tanks greater than 840,000 gallons / 3179 m³ capacity: See Table 2.

Depending on the method, there can be a significant difference in the calculated required capacity. **No matter which method is used, the tank must be equipped with supplemental venting to protect the tank, product and personnel in cases of equipment failure, fire exposure or other conditions that could cause the tank pressure or vacuum to exceed operating limits.**

Capacity Information

Capacity information (Tables 2, 3, 4 and 5) are based on 0.97 specific gravity nitrogen. Nitrogen is the most common blanketing gas. Should you use a different gas, convert the tabular values as follows: For blanketing (pad) gases other than nitrogen, multiply the given nitrogen flow rate values by the conversion factors in Table 3. For gases of other specific gravities, multiply the given nitrogen flow rate by 0.985 and divide by the square root of the appropriate specific gravity.

Bulletin 74.1:ACE95

Table 1. Flow Rate Conversion⁽¹⁾

MULTIPLY MAXIMUM PUMP RATE OUT:	BY	TO OBTAIN ⁽¹⁾ :
U.S. GPM	8.021	SCFH
U.S. GPH	0.1337	SCFH
m ³ /hr	1.01	Nm ³ /h
Barrels/hr	5.615	SCFH
Barrels/day	0.2340	SCFH

1. Gas flow of blanketing gas to replace liquid pumped out.

Table 2. API 2000 Requirements for Thermal Venting Capacity for Tanks Larger than 840,000 gallons / 20,000 barrels / 3179 m³

TANK CAPACITY		IN BREATHING (VACUUM), SCFH / Nm ³ /h OF AIR	
GALLONS	m ³	SCFH	Nm ³ /h
1,050,000	4000	24,000	643
1,260,000	5000	28,000	750
1,470,000	6000	31,000	831
1,680,000	7000	34,000	911
1,890,000	8000	37,000	992
2,100,000	9000	40,000	1072
2,520,000	10,000	44,000	1179
2,940,000	11,000	48,000	1286
3,360,000	13,000	52,000	1394
3,780,000	14,000	56,000	1501
4,200,000	16,000	60,000	1608
5,040,000	19,000	68,000	1822
5,880,000	22,000	75,000	2010
6,720,000	25,000	82,000	2198
7,560,000	29,000	90,000	2412

Table 3. Conversion Factors (for converting Nitrogen flow rates to other gas flow rates)

BLANKET GAS	SPECIFIC GRAVITY	CORRECTION FACTOR
Natural Gas	0.60	1.270
Air	1.00	0.985
Dry CO ₂	1.52	0.797

$$\text{Correction Factor} = \frac{0.985}{\sqrt{\text{SG}}}$$

Table 4. Type ACE95 Capacities

INLET PRESSURE				CAPACITIES IN SCFH / Nm ³ /h OF NITROGEN									
				C _v = 1		C _v = 2		C _v = 4		C _v = 7.5		C _v = 10	
psig	bar	kg/cm ²	kPa	SCFH	Nm ³ /h	SCFH	Nm ³ /h	SCFH	Nm ³ /h	SCFH	Nm ³ /h	SCFH	Nm ³ /h
25	1.7	1.76	172	1130	30.3	2300	61.6	4440	119	9900	265	11,200	300
30	2.1	2.11	207	1280	34.3	2670	71.6	5020	135	11,200	300	13,000	348
40	2.8	2.81	276	1680	45.0	3440	92.2	6780	182	13,500	362	16,400	440
50	3.5	3.52	345	2050	54.9	4090	110	8140	218	17,800	477	20,200	541
60	4.1	4.22	414	2330	62.4	4800	129	9370	251	18,200	488	22,700	608
70	4.8	4.92	483	2670	71.6	5450	146	10,600	284	23,600	632	26,600	713
80	5.5	5.62	552	3010	80.7	6160	165	12,000	322	27,400	734	30,800	825
90	6.2	6.33	621	3410	91.4	6840	183	13,200	354	30,800	825	34,100	914

- continued -

Table 4. Type ACE95 Capacities (continued)

INLET PRESSURE				CAPACITIES IN SCFH / Nm ³ /h OF NITROGEN									
				C _v = 1		C _v = 2		C _v = 4		C _v = 7.5		C _v = 10	
psig	bar	kg/cm ²	kPa	SCFH	Nm ³ /h	SCFH	Nm ³ /h	SCFH	Nm ³ /h	SCFH	Nm ³ /h	SCFH	Nm ³ /h
100	6.9	7.03	690	3690	98.9	7430	199	14,600	391	34,100	914	38,000	1018
110	7.6	7.73	758	4000	107	8110	217	16,000	429	36,800	986	41,300	1107
120	8.3	8.44	827	4370	117	8750	235	17,200	461	38,800	1040	44,600	1195
130	8.9	9.14	896	4590	123	9340	250	18,300	490	43,400	1163	46,300	1241
140	9.6	9.84	965	4930	132	10,100	271	19,500	523	46,500	1246	50,500	1353
150	10.3	10.55	1034	5300	142	10,800	289	21,000	563	49,900	1337	54,500	1461
160	11.0	11.25	1103	5640	151	11,400	306	21,500	576	53,200	1426	58,200	1560
170	11.7	11.95	1172	5950	159	12,000	322	23,000	616	55,800	1495	62,300	1670
180	12.4	12.65	1241	6320	169	12,600	338	24,700	662	59,600	1597	65,900	1766
190	13.1	13.36	1310	6630	178	13,400	359	25,600	686	62,600	1678	69,600	1865
200	13.8	14.06	1379	6970	187	14,000	375	27,200	729	65,100	1745	71,900	1927

Table 5. Type ACE95Sr Capacities

INLET PRESSURE				CAPACITIES IN SCFH / Nm ³ /h OF NITROGEN					
				C _v = 20		C _v = 45		C _v = 60	
psig	bar	kg/cm ²	kPa	SCFH	Nm ³ /h	SCFH	Nm ³ /h	SCFH	Nm ³ /h
25	1.7	1.76	172	26,700	716	60,200	1613	80,000	2144
30	2.1	2.11	207	30,200	809	68,100	1825	90,800	2433
40	2.8	2.81	276	37,500	1005	84,500	2265	112,700	3020
50	3.5	3.52	345	45,700	1225	102,800	2755	137,100	3674
60	4.1	4.22	414	53,800	1442	121,000	3243	161,400	4325
70	4.8	4.92	483	61,800	1656	139,200	3731	185,600	4974
80	5.5	5.62	552	69,900	1873	154,400	4138	209,800	5623
90	6.2	6.33	621	78,000	2090	175,500	4703	234,000	6271
100	6.9	7.03	690	86,000	2305	193,600	5188	258,200	6920
125	8.6	8.79	862	102,100	2736	238,900	6402	306,500	8214
150	10.3	10.55	1034	126,300	3385	284,200	7616	378,900	10,154
175	12.1	12.31	1207	142,400	3816	329,400	8828	427,200	11,449
200	13.8	14.06	1379	166,500	4462	347,700	9318	499,600	13,390

Table 6. Minimum and Maximum Differential Pressures

BODY SIZE		VALVE C _v	INLET PRESSURE RANGE		SPRING PART NUMBER	SPRING FREE LENGTH		SPRING WIRE DIAMETER	
NPS	DN		psig	bar		In.	mm	In.	mm
3/4 and 1	20 and 25	1 to 4	25 to 50	1.7 to 3.4	GC220704X22	1.50	38.1	0.038	0.96
			51 to 120	3.5 to 8.3	GC220705X22	1.50	38.1	0.051	1.30
			121 to 200	8.3 to 13.8	GC220706X22	1.50	38.1	0.059	1.50
1	25	7.5 to 10	25 to 50	1.7 to 3.4	GC220705X22	1.50	38.1	0.051	1.30
			51 to 120	3.5 to 8.3	GC220706X22	1.50	38.1	0.059	1.50
			121 to 200	8.3 to 13.8	GC220709X22	1.50	38.1	0.072	1.83
2	50	20 to 60	25 to 50	1.7 to 3.4	GC220714X22	4.58	116	0.148	3.76
			51 to 120	3.5 to 8.3	GC220712X22	4.00	102	0.177	4.50
			121 to 200	8.3 to 13.8	GC220713X22	4.00	102	0.218	5.54

Bulletin 74.1:ACE95

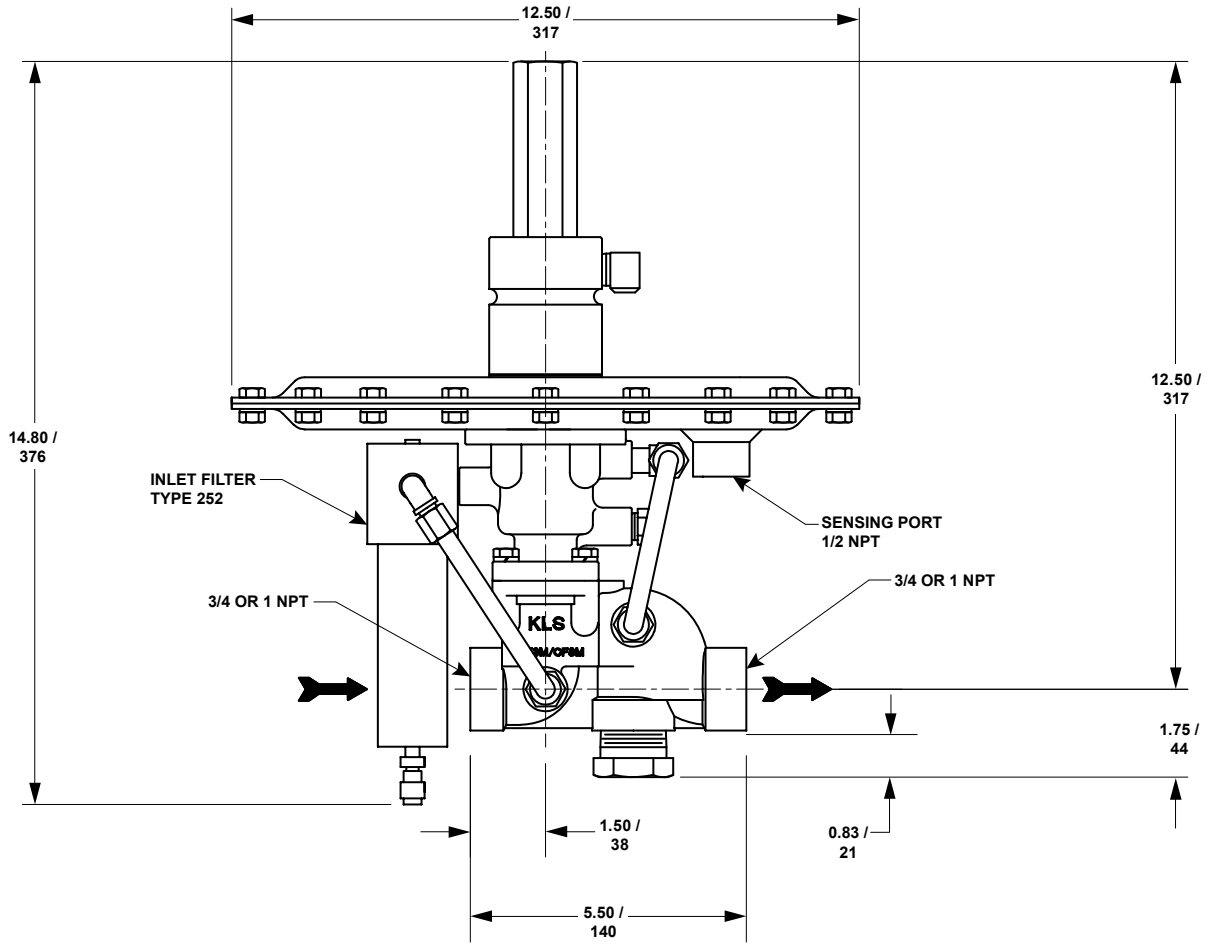

IN. / mm

GE18680

Figure 4. Type ACE95 NPT and In-Line Connection Dimensions

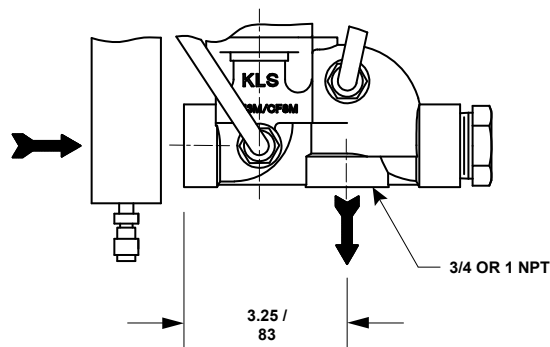

IN. / mm

GE18680

Figure 5. Type ACE95 NPT and Angle Connection Dimensions

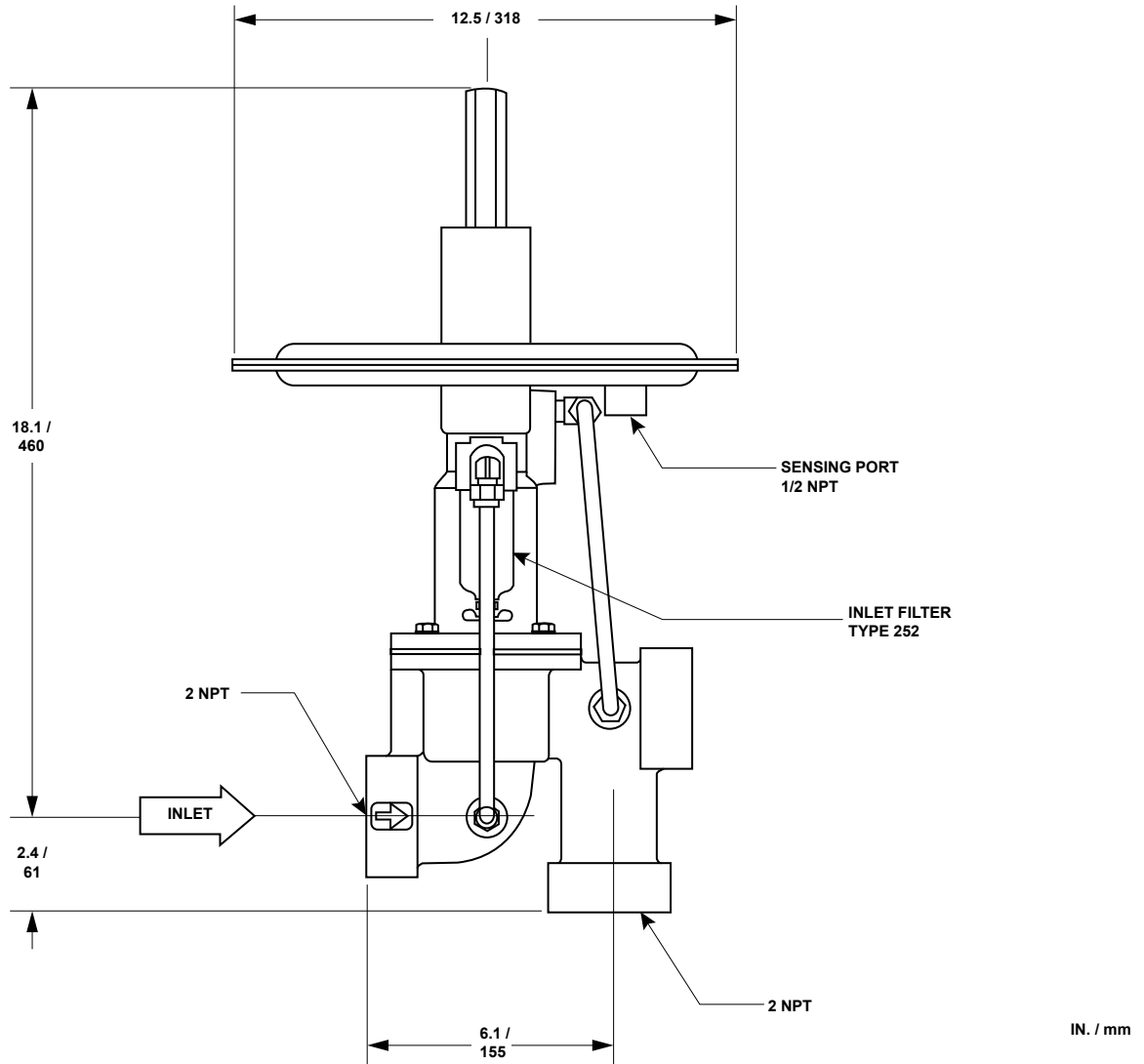

E0736

Figure 6. Type ACE95Sr NPT Dimensions

Table 7. Type ACE95 Dimensions (see Figures 7 and 8)

BODY SIZE	END CONNECTION STYLE	DIMENSIONS									
		Angle-Body						Angle and In-Line ⁽¹⁾ Body			
		A		B				C		High-Pressure ⁽²⁾	
		In.	mm	Without Check Valve	With Check Valve	Low-Pressure	High-Pressure ⁽²⁾	In.	mm	In.	mm
NPS 3/4 / DN 20	NPT	3.25	83	0.83	21	5.03	128				
NPS 1 / DN 25	NPT	3.25	83	0.83	21	5.03	128	12.5	317	14.6	371
	CL150, CL300 and PN 16/25/40 RF Flange	5.89	150	3.47	88	7.67	195				
	CL150 and CL300 RF Weld Neck Flange	5.22	133	2.80	71	7.00	128				
	Sanitary Flange	6.05	154	3.63	92	7.83	199				

1. For In-Line body: available only for NPS 1 / DN 25 body size with CL150 RF flange.
 2. High-pressure body requires a unique spring case which is available as special order.

Bulletin 74.1:ACE95

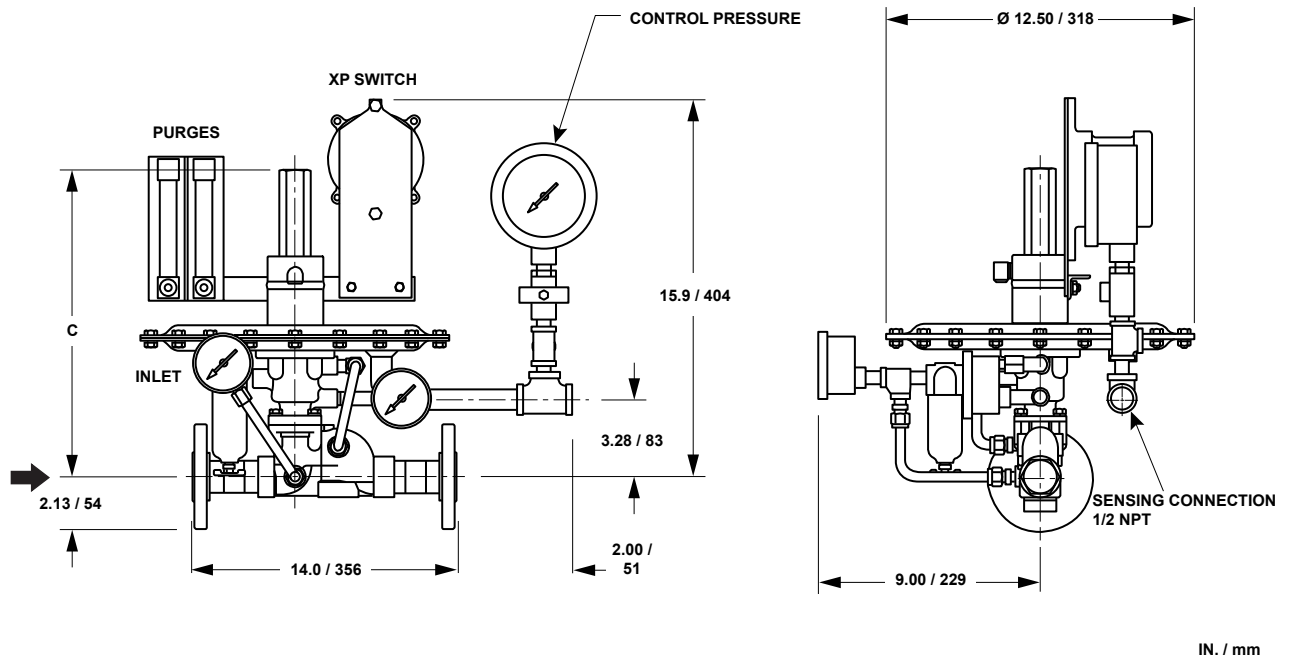

IN. / mm

Figure 7. ACE95 Series Flanged and In-Line Body Dimensions (see Table 7)

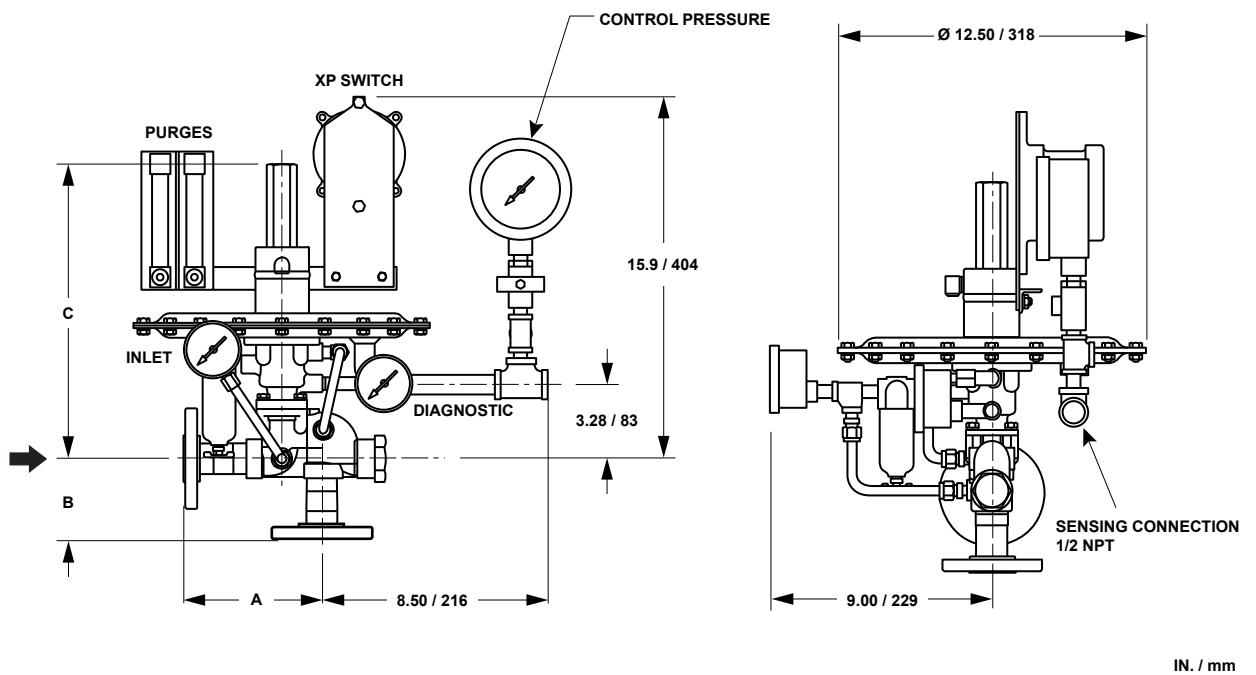

IN. / mm

GC950902

Figure 8. ACE95 Series Flanged and Angle Body Dimensions (See Table 7)

Ordering Information

Refer to the Specifications section on page 2. Carefully review each specification and construction feature, then complete the Ordering Guide on pages 11 and 12.

Also, please complete the Specifications Worksheet at the bottom of the Ordering Guide on page 12.

Ordering Guide

Type (Select One)

- ACE95
- ACE95Sr

Body Size and Inlet Connection Style (Select One)

Type ACE95 (Angled Body)

- 3/4 NPT
- 1 NPT
- NPS 1 / DN 25, CL150 RF
- NPS 1 / DN 25, CL300 RF
- NPS 1 / DN 25, PN 16/25/40 RF
- NPS 1 / DN 25, Sanitary Flange

Type ACE95 (In-Line Body)

- 3/4 NPT
- 1 NPT
- NPS 1 / DN 25, CL150 RF
- NPS 1 / DN 25, CL300 RF
- NPS 1 / DN 25, PN 16/25/40 RF
- NPS 1 x 2 / DN 25 x 50, CL150 RF
- NPS 1 x 2 / DN 25 x 50, PN 16/25/40 RF
- NPS 1 / DN 25, Sanitary Flange

Type ACE95Sr (Angled Body)

- 2 NPT
- NPS 2 / DN 50, CL150 RF
- NPS 2 / DN 50, CL300 RF

Actuator/Diaphragm (Select One)

- Carbon steel with FEP diaphragm
- 316 Stainless steel with FEP diaphragm

Elastomers (Select One)

- Nitrile (NBR)
- Fluorocarbon (FKM)
- Ethylenepropylene (EPDM - FDA)
- Perfluoroelastomer (FFKM)

Main Valve Coefficient (Select One)

Type ACE95

- C_v – 10 (not available in 3/4 NPT)
- C_v – 7.5 (not available in 3/4 NPT)
- C_v – 4
- C_v – 2
- C_v – 1

Type ACE95Sr

- C_v – 60
- C_v – 45
- C_v – 20

Control Pressure Range (Select One)

- 0.5 to 5 in. w.c. / 1 to 12 mbar
- 4 to 10 in. w.c. / 10 to 25 mbar
- 8 to 15 in. w.c. / 20 to 37 mbar
- 0.5 to 1.5 psig / 0.03 to 0.10 bar
- 1 to 1 in. w.c. / -2 to 2 mbar
- 0.5 to -5 in. w.c. / -1 to -12 mbar

Inlet Operating Range (Select One)

- 25 to 50 psig / 1.7 to 3.5 bar
- 51 to 120 psig / 3.5 to 8.3 bar
- 121 to 200 psig / 8.3 to 13.8 bar

Options (Select Desired Options)

- Stainless steel Filter in lieu of standard Aluminum/Zinc
- Inlet Pressure Gauge, Stainless steel
- Control Pressure Gauge, Dwyer®
- Control Gauge, Stainless steel, for setpoint below 2 in. w.c. / 5 mbar
- Control Gauge, Stainless steel, for setpoint above 2 in. w.c. / 5 mbar
- Sensing Line Purge, Acrylic
- Sensing Line Purge, Stainless steel
- Main Line Purge, Acrylic
- Main Line Purge, Stainless steel
- Pressure Switch, X-Proof
- Main Line Check Valve, Stainless steel
- Diagnostic and Inlet Gauges, Stainless steel

Bulletin 74.1:ACE95

Ordering Guide (continued)

Single Array Manifold (Optional)

- Yes, please add a SAM unit to my order. Please specify tank connection size and style (i.e. NPS 2 / DN 50, CL150 RF). Not available for In-Line bodies.

Parts Kit (Optional)

- Yes, please send one parts kit to match this order.

Specification Worksheet	
Application Specifications:	
Product in Tank	_____
Tank Size	_____
Pump In Rate	_____
Pump Out Rate	_____
Blanketing Gas (Type and Specific Gravity)	_____
Conservation Vent Setpoints:	_____ Pressure _____ Vacuum
Pressure Requirements (Please Designate Units):	
Maximum Inlet Pressure (P_{1max})	_____
Minimum Inlet Pressure (P_{1min})	_____
Control Pressure Setting (P_2)	_____
Maximum Flow (Q_{max})	_____
Other Specifications:	
Is a vapor recovery regulator required?	<input type="checkbox"/> Yes <input type="checkbox"/> No
Other Requirements:	_____

Industrial Regulators

Emerson Process Management Regulator Technologies, Inc.

USA - Headquarters
McKinney, Texas 75070 USA
Tel: +1 800 558 5853
Outside U.S. +1 972 548 3574

Asia-Pacific
Shanghai 201206, China
Tel: +86 21 2892 9000

Europe
Bologna 40013, Italy
Tel: +39 051 419 0611

Middle East and Africa
Dubai, United Arab Emirates
Tel: +971 4811 8100

Natural Gas Technologies

Emerson Process Management Regulator Technologies, Inc.

USA - Headquarters
McKinney, Texas 75070 USA
Tel: +1 800 558 5853
Outside U.S. +1 972 548 3574

Asia-Pacific
Singapore 128461, Singapore
Tel: +65 6770 8337

Europe
Bologna 40013, Italy
Tel: +39 051 419 0611
Chartres 28008, France
Tel: +33 2 37 33 47 00

Middle East and Africa
Dubai, United Arab Emirates
Tel: +971 4811 8100

TESCOM

Emerson Process Management Tescom Corporation

USA - Headquarters
Elk River, Minnesota 55330-2445, USA
Tels: +1 763 241 3238
+1 800 447 1250

Europe
Selmsdorf 23923, Germany
Tel: +49 38823 31 287

Asia-Pacific
Shanghai 201206, China
Tel: +86 21 2892 9499

For further information visit www.fisherregulators.com

The Emerson logo is a trademark and service mark of Emerson Electric Co. All other marks are the property of their prospective owners. Fisher is a mark owned by Fisher Controls International LLC, a business of Emerson Process Management.

The contents of this publication are presented for informational purposes only, and while every effort has been made to ensure their accuracy, they are not to be construed as warranties or guarantees, express or implied, regarding the products or services described herein or their use or applicability. We reserve the right to modify or improve the designs or specifications of such products at any time without notice.

Emerson Process Management Regulator Technologies, Inc. does not assume responsibility for the selection, use or maintenance of any product. Responsibility for proper selection, use and maintenance of any Emerson Process Management Regulator Technologies, Inc. product remains solely with the purchaser.