

Fisher™ 8560 Eccentric Disc Butterfly Control Valve

Contents

Introduction	1
Scope of Manual	1
Description	1
Specifications	2
Installation	3
Valve Orientation	5
Maintenance	9
Packing Maintenance	12
Seal Ring Maintenance for NPS 3 through 12 Only	16
Seal Ring Maintenance for NPS 2	21
Disc, Drive Shaft and Bearing Maintenance for NPS 3 through 12 Only	22
Disc, Drive Shaft and Bearing Maintenance for NPS 2	25
Actuator Mounting	26
Parts Ordering	28
Retrofit Kits for ENVIRO-SEAL™ Packing	29
Repair Kits for ENVIRO-SEAL Packing	29
Parts List	29

Figure 1. Fisher 8560 Valve with 1052 Actuator and DVC6000 Series Digital Valve Controller



Introduction

Scope of Manual

This instruction manual includes installation, maintenance, and parts information for NPS 2 through 12 8560 Eccentric Disc Butterfly Control Valves (see figure 1). Refer to separate instruction manuals for information covering the actuator and accessories.

Do not install, operate, or maintain 8560 valves without being fully trained and qualified in valve, actuator, and accessory installation, operation, and maintenance. To avoid personal injury or property damage, it is important to carefully read, understand, and follow all the contents of this manual, including all safety cautions and warnings. If you have any questions about these instructions, contact your [Emerson sales office](#) or Local Business Partner before proceeding.

Description

The seal design of the 8560 eccentric disc high performance butterfly valve provides excellent shutoff capability. The valve includes PTFE-filled or graphite packing rings that electrically bond the shaft to the valve body. This valve has a spline drive shaft end, and soft or metal seal rings for use in a wide variety of applications.

Table 1. Specifications

<p>Valve Size and End Connection Styles</p> <p>NPS ■ 2, ■ 3, ■ 4, ■ 6, ■ 8, ■ 10, and ■ 12 valves and in Wafer or Single flanged style (NPS 2 available in wafer only)</p> <p>Maximum Inlet Pressure⁽¹⁾</p> <p>Carbon Steel and Stainless Steel Valve Bodies: Consistent with CL150 and 300 pressure/temperature ratings per ASME B16.34 unless limited by material temperature capabilities. NPS 2 is also consistent with CL600.</p> <p>Maximum Pressure Drops⁽¹⁾</p> <p>Consistent with CL150 and 300 pressure-temperature ratings per ASME B16.34 except for PTFE, UHMWPE and Phoenix III seals which are derated at some higher pressure-temperature values. Refer to figure 2</p> <p>Shutoff Classifications</p> <ul style="list-style-type: none"> ■ PTFE, Reinforced PTFE, and UHMWPE⁽³⁾ Seals: Bidirectional shutoff to Class VI per ANSI/FCI 70-2 and IEC 60534-4. ■ NPS 2 Metal Seal: Bidirectional shutoff. 0.001% of maximum valve capacity (1/10) of Class IV per ANSI/FCI 70-2 and IEC 60534-4. Maximum Pressure drop is 51 bar (740 psi) forward and 6.9 bar (100 psi) reverse. ■ NOVEX Seal: For NPS 3 through 12. Unidirectional shutoff is 0.0001% of maximum valve capacity (1% of Class IV) in the reverse flow direction per ANSI/FCI 70-2 and IEC 60534-4. ■ Phoenix III Seal: For NPS 3 through 12. Bidirectional shutoff to Class VI per ANSI/FCI 70-2 and IEC 60534-4. For the optional Phoenix III Fire-Tested seal, consult your Emerson sales office or Local Business Partner. 	<p>Flow Characteristics</p> <p>Approximately linear</p> <p>Disc Rotation</p> <p>Clockwise to close (when viewing from the drive shaft end) through 90 degrees of disc rotation (see figure 10)</p> <p>Flow Direction</p> <p>See figure 3</p> <p>Actuator/Valve Action</p> <p>With the diaphragm or piston actuators, the valve action is field-reversible. Refer to information in the Installation section.</p> <p>Valve Classification</p> <p>Face-to-face dimensions of NPS 3 through 12 are in CL150 and 300, and meet API 609 or MSS-SP-68 standards for face-to-face dimensions of wafer-style and single flange valves.</p> <p>Shaft Diameters</p> <p>See table 2</p> <p>Approximate Weights</p> <p>See table 2</p> <p>ENVIRO-SEAL Packing</p> <p>This optional PTFE or graphite packing system provides excellent sealing, guiding, and transmission of loading forces to control liquid and gas emissions (see figure 8). See bulletin 59.3:041 ENVIRO-SEAL Packing System for Rotary Valves (D101638X012) for more information.</p>
---	---

1. The pressure/temperature limits in this manual and any applicable standard or code limitation for valves should not be exceeded.

2. For components selection and applicable fire tested standards and codes, consult your Emerson sales office.

3. UHMWPE stands for ultra high molecular weight polyethylene.

Table 2. Valve Size, Shaft Diameter, and Approximate Weight

VALVE SIZE, NPS	CLASS	SHAFT DIAMETER		APPROXIMATE WEIGHT			
		mm	Inches	Wafer-Style		Single-Flange	
				kg	Pounds	kg	Pounds
2	150/300/600	12.7	1/2	4.3	9.5	---	---
3	150	12.7	1/2	4.5	10	6.4	14
	300	15.9	5/8	5.9	13	11	25
4	150	15.9	5/8	8.6	19	11	24
	300	19.1	3/4	10	23	18	39
6	150	19.1	3/4	13	29	16	35
	300	25.4	1	15	33	27	59
8	150	25.4	1	21	47	27	59
	300	31.8	1-1/4	24	53	42	93
10	150	31.8	1-1/4	34	75	40	88
	300	38.1	1-1/2	44	96	78	172
12	150	38.1	1-1/2	49	107	62	137
	300	44.5	1-3/4	64	141	131	288

Installation

The valve is normally shipped as part of a control valve assembly, with the power actuator mounted on the valve. If the valve or actuator have been purchased separately, or if the actuator has been removed for maintenance, mount the actuator on the valve, and adjust actuator travel before inserting the valve body into the line. This is necessary due to the measurements that must be made during the actuator calibration adjustment process. Refer to the Actuator Mounting section of this manual to mount the actuator on the valve. Refer to the actuator instruction manual for mounting and adjusting instructions before proceeding.

⚠ WARNING

Always wear protective gloves, clothing, and eyewear when performing any installation operations to avoid personal injury.

To avoid personal injury or property damage resulting from the sudden release of pressure, do not install the valve assembly where service conditions could exceed the limits given in this manual, the limits on the appropriate nameplates, or the matching pipe flange rating. Use pressure-relieving devices as required by government or accepted industry codes and good engineering practices.

Check with your process or safety engineer for any additional measures that must be taken to protect against process media.

If installing into an existing application, also refer to the WARNING at the beginning of the Maintenance section in this instruction manual.

⚠ WARNING

The valve configuration and construction materials are selected to meet particular pressure, temperature, pressure drop, and controlled fluid conditions. Responsibility for the safety of process media and compatibility of valve materials with process media rests solely with the purchaser and end-user. Since some valve body/trim material combinations are limited in their pressure drop and temperature range capabilities, do not apply any other conditions to the valve without first contacting your [Emerson sales office](#) or Local Business Partner.

Table 3. Maximum Allowable Inlet Pressure for M35-1 and CW2M Valve Bodies⁽¹⁾

TEMPERATURE	M35-1			CW2M		
	150	300	600 ⁽²⁾	150	300	600 ⁽²⁾
°C	Bar					
-46 to 38	15.8	41.3	82.7	20.0	51.7	103.4
93	13.8	36.5	72.7	17.9	51.7	103.4
149	13.1	34.1	68.2	15.9	50.3	100.3
204	12.7	33.1	65.8	13.8	48.6	97.2
260	11.7	32.8	65.5	11.7	45.9	91.7
°F	Psig					
-50 to 100	230	600	1200	290	750	1,500
200	200	530	1055	260	750	1,500
300	190	495	990	230	730	1,455
400	185	480	955	200	705	1,410
500	170	475	950	170	665	1,330

1. M35-1 and CW2M valve material are not included in ASME B16.34 pressure/temperature ratings. The designations 150 and 300 for this valve material are used only to indicate relative pressure/retaining capabilities and are not ASME pressure/temperature rated classes.
2. CL600 is only available in the NPS 2.

Table 4. Construction Material Temperature Limits⁽¹⁾

COMPONENTS AND MATERIALS OF CONSTRUCTION	TEMPERATURE LIMITS	
	°C	°F
Valve Body Material / Disc / Shaft Material		
Carbon Steel / CF8M / S17400	-29 to 427	-20 to 800
Carbon Steel / CF8M / S20910	-29 to 427	-20 to 800
CF8M / CF8M / S17400	-73 to 427	-100 to 800
CF8M / CF8M / S20910	-198 to 538	-325 to 1000
CG8M / CG8M / S20910	-198 to 538	-325 to 1000
Bearing Material		
PEEK / PTFE lined	-73 to 260	-100 to 500
Metal (NOVEX or Phoenix III only)	-198 to 538	-325 to 1000
Packing Material		
PTFE V-Rings	-46 to 232	-50 to 450
Graphite rings (NOVEX or Phoenix III only)	-198 to 538	-325 to 1000
Seal Ring		
PTFE (Standard) Soft Seal Ring	-46 to 232	-50 to 450
Reinforced PTFE Soft Seal Ring	-46 to 232	-50 to 450
UHMWPE Soft Seal Ring	-18 to 93	0 to 200
NOVEX Metal Seal Ring	-46 to 538	-50 to 1000
Phoenix III Metal Seal Ring		
Fluorocarbon backup ring	-40 to 232	-40 to 450
Phoenix III Fire-Tested ⁽²⁾ Metal Seal Ring		
Fluorocarbon backup ring (Specify metal bearings and graphite packing)	-40 to 232 ⁽²⁾	-40 to 450 ⁽²⁾

1. Refer to Ordering Matrix for 8560 Valves. For selection temperatures not shown above, contact your [Emerson sales office](#) or Local Business Partner.
2. For component selection and applicable fire-tested standards and codes, consult your Emerson sales office or Local Business Partner.

1. Install a three-valve bypass around the control valve assembly if continuous operation is necessary during inspection and maintenance of the valve.
2. Inspect the valve to be certain that it is free of foreign material.

CAUTION

Be certain that adjacent pipelines are free of any foreign material, such as pipe scale or welding slag, that could damage the valve sealing surfaces.

Figure 2. Maximum Pressure/Temperature Ratings

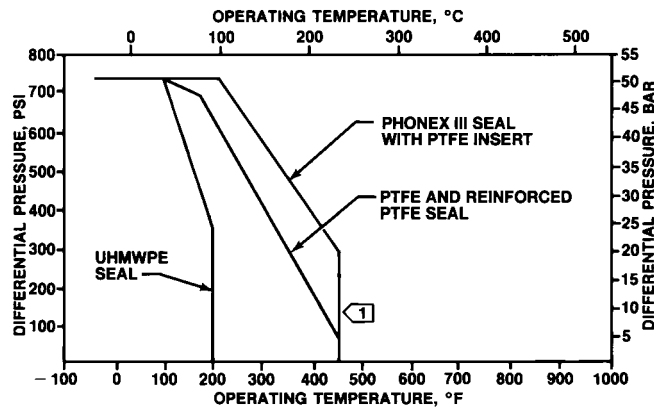

A6306-2

NOTE:

TEMPERATURE LIMITATIONS DO NOT ACCOUNT FOR THE ADDITIONAL LIMITATIONS IMPOSED BY THE BACKUP RING USED WITH THIS SEAL. TO DETERMINE THE EFFECTIVE TEMPERATURE LIMITATION OF THE APPROPRIATE SEAL/BACKUP RING COMBINATION, REFER TO TABLE 4.

Valve Orientation

When installing the valve, it is recommended that the valve drive shaft be horizontal as shown in figure 1.

Note

Due to its weight, the 1052 size 70 actuator must be externally supported when mounted in a horizontal position.

Valve Direction

The high performance butterfly valve is designed to allow flow in either direction when in the open position. When in the closed position, high pressure should be applied to a specific side of the disc to provide best performance and optimal valve life (see list of seal types below). See figure 3.

Applications with bi-directional seals, such as soft or Phoenix III, under normal operating conditions can (at different times) experience pressure in both directions; the highest of the two pressures should be exerted on the preferred side of the disc. If the two pressures are equal, then the one lasting the longest period of time should be applied to the preferred side.

1. For PTFE, Reinforced PTFE, and UHMWPE seal rings: This seal is bidirectional. For optimal performance, high pressure should be applied to the front (retaining ring side) of the disc.
2. For metal seal rings:
 - a. NOVEX seal: The NOVEX seal is uni-directional. High pressure at the closed position MUST be at the back (waterway side) of the disc.
 - b. Phoenix III Seal: This seal is bidirectional. For best performance, high pressure at the closed position should be applied to the back (waterway side) of the disc.
 - c. NPS 2 Seal: The preferred direction of installation is with high pressure at the front (retaining ring side) of the disc. Reverse shutoff is permissible at lower pressure (see the specifications table).

Figure 3. Flow Direction

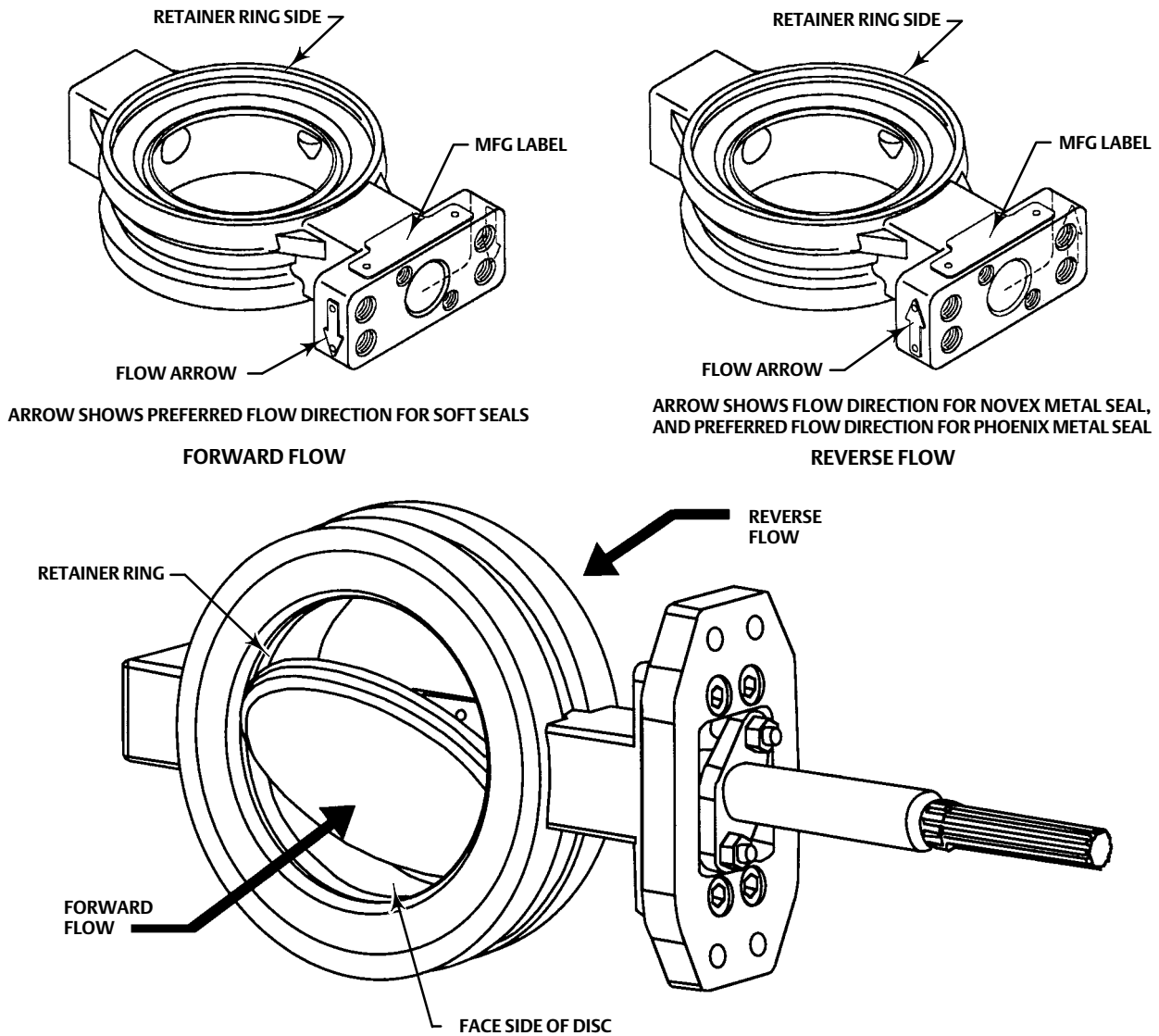

NOTES:

1. BY Emerson Automation Solutions DEFINITION:
- FORWARD FLOW IS INTO THE FACE SIDE OF THE DISC.
 - REVERSE FLOW IS INTO THE HUB SIDE OF THE DISC.

75B1181-A
A6882

Table 5. Special Spiral Wound Gasket Dimensions, Inches

Valve Size, NPS	Class	Gasket Internal Diameter	Gasket Outside Diameter	Centering Outside Diameter ⁽¹⁾
3	150	4.25	5.00	5.375
3	300	4.25	5.00	5.875
4	150	5.25	6.125	6.875
4	300	5.25	6.125	7.125

1. Dimension per API 601 and ASME 16.5 Flanges.

Table 6. Stud Bolt and Hex Head Cap Screw Data⁽¹⁾

VALVE SIZE, NPS	WAFER STYLE						SINGLE FLANGE STYLE					
	CL150			CL300			CL150			CL300		
	No. of Stud Bolts	Size Dia Inch & Thread	A Dimension, Inch	No. of Stud Bolts	Size Dia Inch & Thread	A Dimension, Inch	No. of Cap Screws	Size Dia Inch & Thread	B Dimension, Inch	No. of Cap Screws	Size Dia Inch & Thread	B Dimension, Inch
2 ⁽²⁾	4	5/8-11	5	8	5/8-11	5.25	---	---	---	---	---	---
3	4	5/8-11	5.75	8	3/4-10	6.5	8	5/8-11	1.875	16	3/4-10	2
4	8	5/8-11	6	8	3/4-10	7	16	5/8-11	2	16	3/4-10	2.25
6	8	3/4-10	6.5	12	3/4-10	7.5	16	3/4-10	2	24	3/4-10	2.5
8	8	3/4-10	7	12	7/8-9	9	16	3/4-10	2.25	24	7/8-9	3
10	12	7/8-9	8	16	1-8	10	24	7/8-9	2.5	32	1-8	3.5
12	12	7/8-9	8.5	16	1-1/8-8	11	24	7/8-9	2.75	32	1-1/8-8	3.75

1. Thread engagement in accordance with ASME B31.3.
 2. The NPS 2 valve is only available in wafer style and is multirated to CL150, 300 and 600. The CL600 stud bolts require 8 bolts, have a dia. of 5/8-11, and are 6 inches long.

Figure 4. Stud Bolts and Cap Screws for Installation (also see table 6)

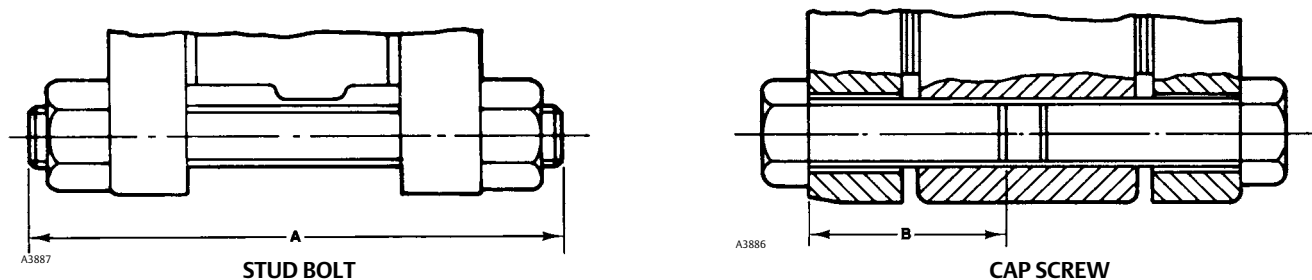

Installing the Valve in the Pipeline

⚠ WARNING

The edges of a rotating disc have a shearing effect that may result in personal injury. To help prevent such injury, stay clear of the disc edges when rotating the disc (key 3, figure 14).

CAUTION

Damage to the disc will occur if any pipe flanges or piping connected to the valve interfere with the disc rotation path. If the piping flange has a smaller inner diameter than what is specified for schedule 80 piping, measure carefully to be certain the disc rotates without interference before putting the valve into operation.

CAUTION

Damage to the disc (key 3) sealing surfaces may occur if the disc is not closed when the valve is being removed from the pipeline. If necessary, use a temporary pressure source on the actuator to retain the disc in the closed position while removing the valve from the pipeline.

1. For Fail-Open Actuators: It will be necessary to provide a temporary loading pressure to the actuator diaphragm to move the valve disc to the closed position. Observe the above Warning when closing the valve. If a loading pressure is required, use caution when working with the valve. If the loading pressure is disconnected, the disc will open rapidly.
2. With the disc in the closed position, install line flange gaskets, and install the valve between the pipeline flanges.

⚠ WARNING

If spiral wound gaskets are to be used with an NPS 3 or 4 CL150 or 300 single flange valve, special spiral wound gaskets conforming to the dimensions listed in the table 5 MUST be used. Improperly sized gaskets may increase the likelihood of 1) excessive seat leakage, 2) damage due to contact with valve internals, and 3) external leakage; which may result in personal injury and/or property damage due to a sudden increase or decrease of pressure within - or release of pressure from - the pipeline. The special dimension spiral wound gaskets can be obtained from your local spiral wound gasket vendor.

Note

The remaining single flange valve sizes (NPS 6 through 12) and all wafer style valves (NPS 2 through 12) use the standard size spiral wound gaskets. Only the single flange valves in the sizes and pressures listed in table 5 require special spiral wound gaskets.

Select the appropriate gaskets for the application. Flat sheet, spiral wound (NPS 6 through 12), or other gasket types made to ASME 16.5 group or a user's standards can be used for 8560 valves depending on the service conditions and applications.

3. Install the flange studs:

Note

Lubricate line flange studs or bolts before inserting them into flanges. If necessary, provide additional support for the control valve assembly because of its combined weight.

- **Flange studs:** Install two or more line flange studs into the line flanges to help hold the valve in position while centering the valve. Carefully center the valve on the flanges to ensure disc clearance.

Figure 5. Optional Shaft-to-Valve Body Bonding Strap Assembly

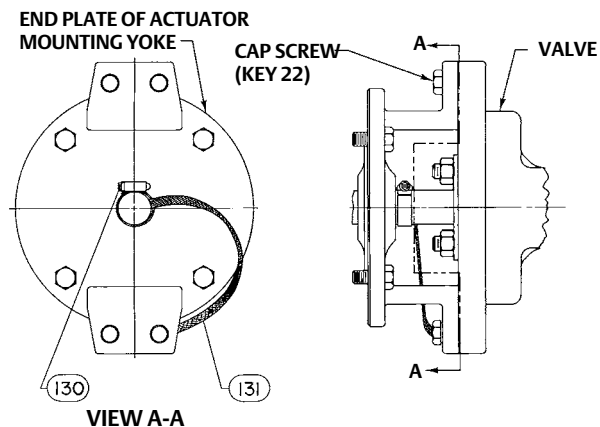

B2434

- Select and install two pipe line gaskets.
 - **Flange Cap Screws:** If line flange cap screws are used, be certain the cap screw threads engage the tapped holes to a depth equal to the flange cap screw diameter.
4. Install the remaining line flange bolting to secure the valve in the pipeline. Tighten the nuts to the line flange studs, or cap screws, in a crisscross pattern to ensure proper alignment of valve, gaskets, and flanges.

Packing Adjustment and Shaft Bonding

⚠ WARNING

Personal injury could result from packing leakage. Valve packing was tightened before shipment; however the packing might require some readjustment to meet specific service conditions. Check with your process or safety engineer for any additional measures that must be taken to protect against process media.

CAUTION

Use caution when tightening packing follower nuts because over-tightening the nuts will accelerate wear and could produce higher rotating friction loads on the valve stem.

1. For PTFE or graphite packing: tighten standard packing follower nuts only enough to prevent shaft leakage. Excessive tightening of packing will accelerate wear and could produce higher rotating friction loads on the valve stem. If necessary, refer to the Packing Maintenance section.
2. ENVIRO-SEAL Packing System will not require this initial re-adjustment. Refer to the separate ENVIRO-SEAL Packing System for Rotary Valves instruction manual (D101643X012) for repair and replacement procedures.
3. For hazardous atmosphere or oxygen service valves, read the following Warning, and provide the bonding strap assembly mentioned below if the valve is used in an explosive atmosphere.

⚠ WARNING

The valve drive shaft is not necessarily grounded to the pipeline when installed. Personal injury or property damage could result from an explosion caused by a discharge of static electricity from the valve components if the process fluid or the atmosphere around the valve is flammable. To avoid personal injury or property damage, make sure the valve is grounded to the pipeline before placing the valve assembly into service.

Standard PTFE packing is composed of a partially conductive carbon-filled PTFE female adaptor with PTFE V-ring packing. Standard graphite packing is composed of all conductive graphite ribbon packing rings. Alternate shaft-to-valve body bonding is available for hazardous service areas where the standard packing is not sufficient to bond the shaft to the valve (see the following step).

For oxygen service applications it is necessary to provide alternate shaft-to-valve body bonding according to the following step.

4. Attach the bonding strap assembly (key 131, figure 5) to the shaft with the clamp (key 130, figure 5), and connect the other end of the bonding strap assembly to the valve with the cap screw (key 22, figure 5).
5. For more information, refer to the Packing Maintenance subsection below.

Maintenance

Valve parts are subject to normal wear and must be inspected and replaced as necessary. The frequency of inspection and replacement depends upon the severity of service conditions. Instructions are given in this section for replacing

packing, seal ring, disc, shaft, bearings, and other valve parts. Also, instructions are provided for changing valve action, mounting, and adjusting the actuator. Refer to the actuator instruction manual for additional information for mounting and adjusting the actuator.

CAUTION

It is possible to damage the valve if the actuator travel stops are not properly adjusted before stroking the valve.

⚠ WARNING

Avoid personal injury or property damage from sudden release of process pressure or bursting of parts. Before performing any maintenance operations:

- Do not remove the actuator from the valve while the valve is still pressurized.
- Always wear protective gloves, clothing, and eyewear when performing any maintenance operations to avoid personal injury.
- Disconnect any operating lines providing air pressure, electric power, or a control signal to the actuator. Be sure the actuator cannot suddenly open or close the valve.
- Use bypass valves or completely shut off the process to isolate the valve from process pressure. Relieve process pressure from both sides of the valve. Drain the process media from both sides of the valve.
- Vent the pneumatic actuator loading pressure and relieve any actuator spring precompression.
- Use lock-out procedures to be sure that the above measures stay in effect while you work on the equipment.
- The valve packing box may contain process fluids that are pressurized, *even when the valve has been removed from the pipeline*. Process fluids may spray out under pressure when removing the packing hardware or packing rings, or when loosening the packing box pipe plug.
- The edges of a rotating disc have a shearing effect that may result in personal injury. To help prevent such injury, stay clear of the disc edges when rotating the disc (key 3).
- Check with your process or safety engineer for any additional measures that must be taken to protect against process media.

CAUTION

During any of the following steps, do not rotate the disc past 90 degrees in the open direction. Rotating the disc past 90 degrees can damage the seal ring.

Stopping Leakage

For PTFE-filled or graphite standard packing arrangements covered in this manual, often leakage from the packing can be stopped by tightening the packing flange nuts just enough to stop the leak.

CAUTION

Use caution when tightening the nuts because over-tightening the nuts can damage packing box parts.

- If tightening the packing flange nuts does not stop the leakage, use the following procedures to remove the control valve assembly from the pipeline. Remove the actuator when removing and replacing packing parts.
- If the leakage comes from the outside diameter of the packing box, it is possible that the leakage is caused by nicks or scratches on the packing box wall. Carefully inspect the packing box bore and valve drive shaft when the packing is removed. Use the following steps to remove the actuator and to remove and replace the packing parts.

Removing the Actuator

1. Isolate the control valve from the line pressure, release pressure from both sides of the valve body, and drain the process media from both sides of the valve. If using a power actuator, also shut off all pressure lines to the power actuator, and release all pressure from the actuator. Use lock-out procedures to be sure that the above measures stay in effect while you work on the equipment.

CAUTION

Damage to the disc (key 3) sealing surfaces may occur if the disc is not closed when the valve is being removed from the pipeline. If necessary to overcome spring force, use a temporary pressure source on the actuator to close the disc. Also, maintain the pressure to retain the disc in the closed position while removing the valve from the pipeline.

2. Be sure the disc is in the closed position before attempting to remove the valve from the pipeline or flanges.

⚠ WARNING

The edges of a rotating disc close with a shearing effect that may result in personal injury. To help prevent such injury, stay clear of the disc edges when rotating the disc (key 3).

For Fail-Open Actuators: It will be necessary to provide a temporary loading pressure to the actuator diaphragm to move the valve disc to the closed position. Observe the above Warning when closing the valve. If a loading pressure is required, use caution when working with the valve. If the loading pressure is disconnected, the disc will open rapidly.

Figure 6. Lever-Shaft Orientation

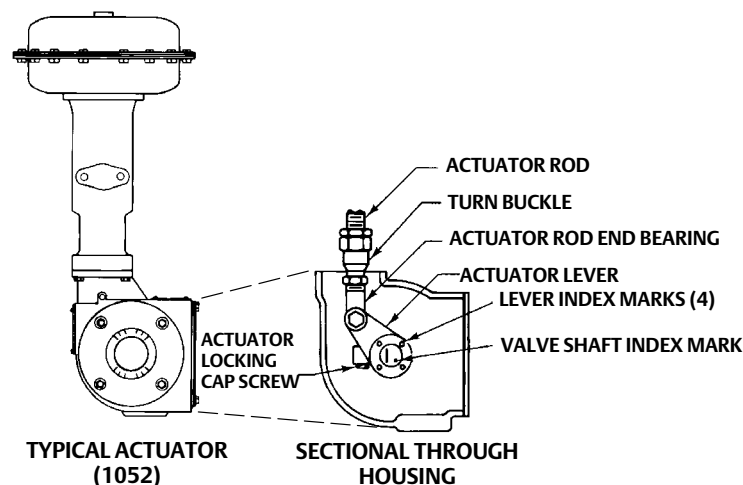

C0784

3. With the disc in the closed position, remove line bolting, remove the control valve assembly from the pipeline, and place it on a flat working surface with the seal retainer ring facing up.
4. If a grounding strap is used (see figure 5), remove the hex nut to release the end of the strap. Remove the clamp (key 130) and strap (key 131).
5. Note the orientation of the actuator with respect to the valve body (see figure 6), and remove the actuator cover to note the lever orientation with respect to the valve drive shaft (see figure 7).

When re-assembling the control valve assembly, you will need to correctly position the marks on the end of the valve drive shaft and the valve body with respect to the actuator case and lever arm. Refer to the Actuator Mounting section and figure 7 for the location of the marks on the valve drive shaft end. Additional information is provided in the actuator manual to assist with disassembly, re-assembly, and travel adjustments. When removing the valve drive shaft from the actuator lever, do not loosen the actuator turnbuckle adjustment. Remove the cap screw from the actuator lever (figure 7).

CAUTION

When removing the actuator from the valve, do not use a hammer or similar tool to drive the actuator lever off the valve shaft. Driving the lever off the valve shaft could damage the disc, seal ring, bearings or valve body.

If necessary, use a wheel puller to remove the actuator lever from the valve shaft. It is okay to tap the wheel puller screw lightly to loosen the lever, but hitting the screw with excessive force could damage the disc, seal ring, bearings or valve body.

6. Remove the actuator mounting screws (key 14, figure 14).
7. Remove the valve from the actuator.

Packing Maintenance

Standard graphite packing is composed of all conductive packing rings. PTFE-filled packing has a partially conductive packing ring (such as a carbon-filled PTFE female adaptor) to electrically bond the shaft to the valve body.

If the valve is equipped with the optional ENVIRO-SEAL Packing System, refer to the separate ENVIRO-SEAL Packing System for Rotary Valves instruction manual (D101643X012) for packing maintenance procedures.

When replacing the packing, it is recommended to remove the control valve assembly from the pipeline because valve/actuator adjustments must be made with the valve out of the pipeline.

Disassembly

Key numbers and part locations are shown in figure 8 unless otherwise noted.

1. Remove the packing flange nuts (key 101) and the packing flange (key 102).
2. Remove the old packing rings, using a formed hook.

CAUTION

Carefully use the hook. Avoid damaging the drive shaft or packing box wall. Scratches on valve surfaces can cause leakage. (Note: the packing box ring (Key 107) can remain in place when replacing packing only.)

3. Clean all accessible metal parts and surfaces to remove particles that would prevent the packing from sealing.

Figure 7. Actuator Mounting Styles and Positions

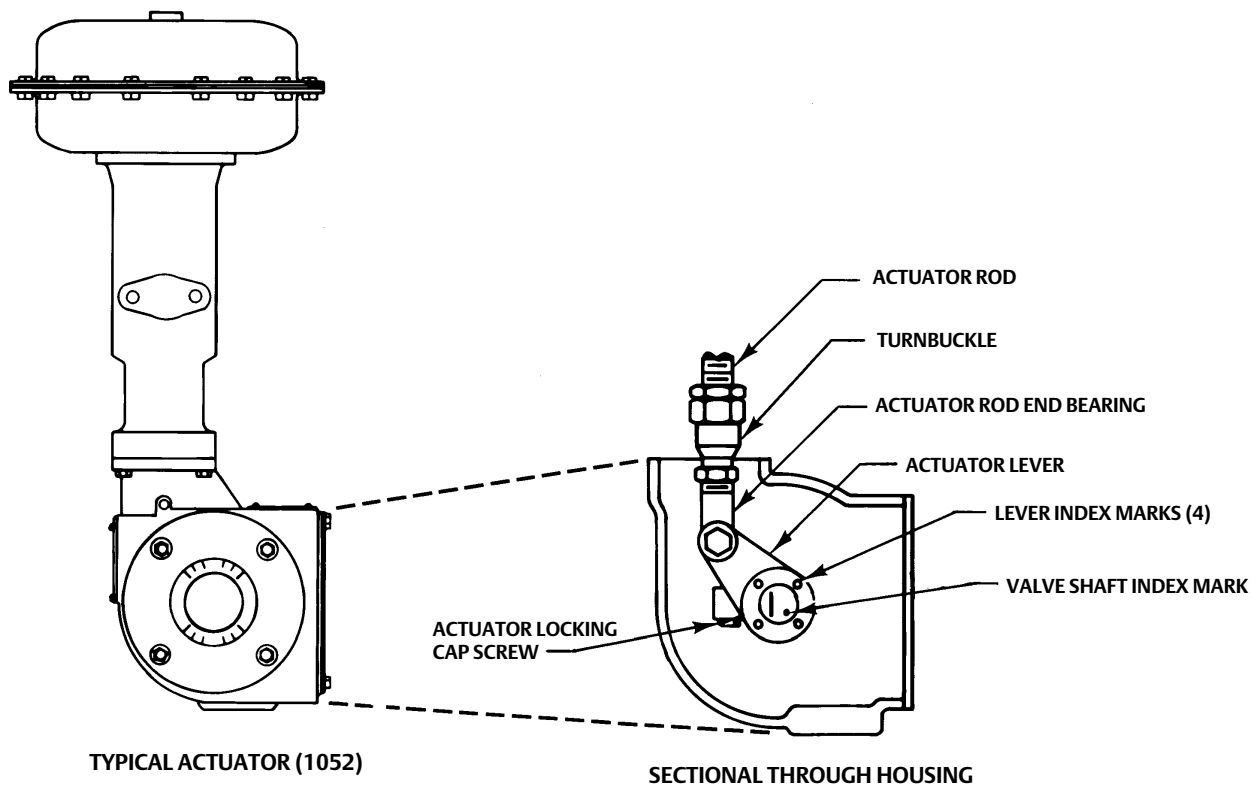

C0784

Assembly

Inspect the shaft: If it is damaged, it cannot make a good seal with the packing, and it must be replaced. If the leakage comes from the outside diameter of the packing, it is possible that the leakage is caused by nicks or scratches around the packing box wall. Inspect the packing box wall for nicks and scratches when performing the following procedures.

If the valve is equipped with the ENVIRO-SEAL packing system refer to the ENVIRO-SEAL Packing System for Rotary Valves instruction manual for assembly.

Note

Except with oxygen service, lightly lubricate new PTFE V-rings with a silicone-base lubricant to aid in assembly.

⚠ WARNING

Do not lubricate parts when used in oxygen service, or where the lubrication is incompatible with the process media. Any use of lubricant can lead to the sudden explosion of media due to the oil/oxygen mixture, causing personal injury or property damage.

Figure 7. Actuator Mounting Styles and Positions (continued)

ACTUATOR		VALVE CLOSED	MOUNTING POSITION 1	MOUNTING POSITION 2	MOUNTING POSITION 3	MOUNTING POSITION 4
MOUNTING	STYLE					
RIGHT-HAND	STYLE A					
	STYLE B					
LEFT-HAND	STYLE C					
	STYLE D					
<p>NOTES: 1. ARROW ON LEVER INDICATES DIRECTION OF ACTUATOR THRUST TO OPEN VALVE. 2. F - FORWARD FLOW; R - REVERSE FLOW</p>						

43A5323-D

Figure 8. Packing Arrangements

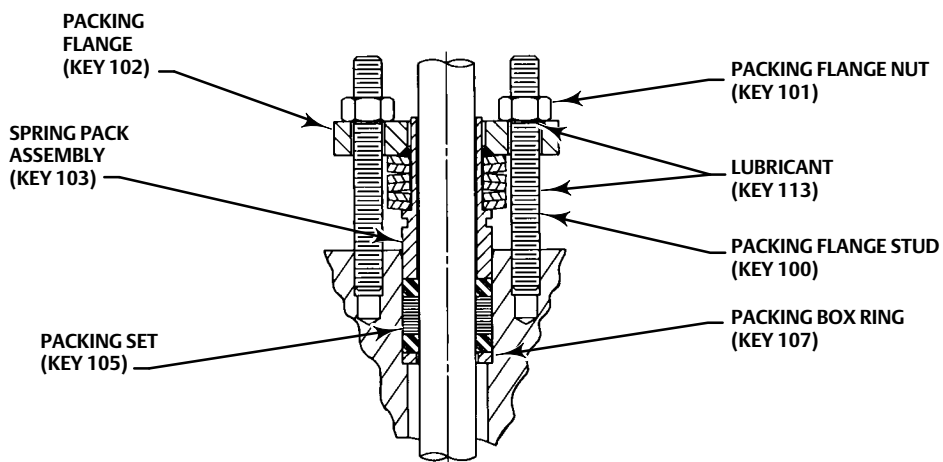
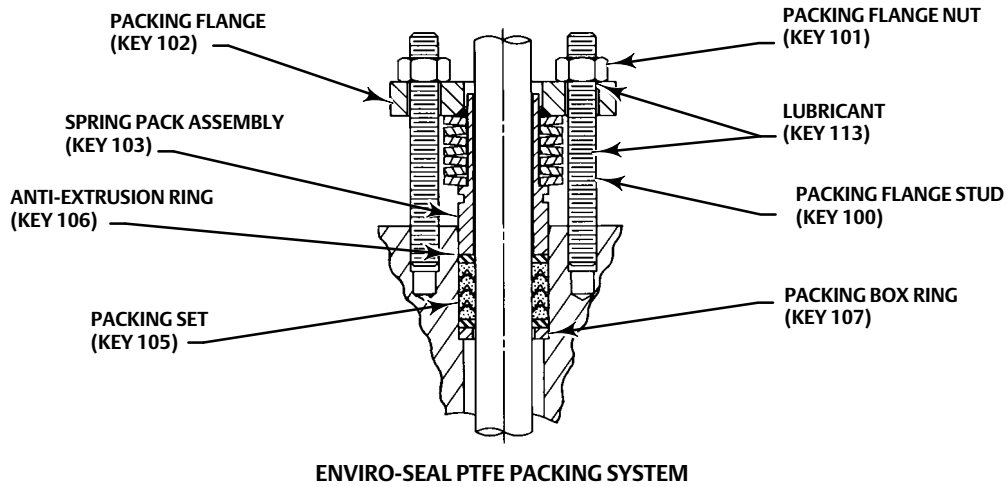
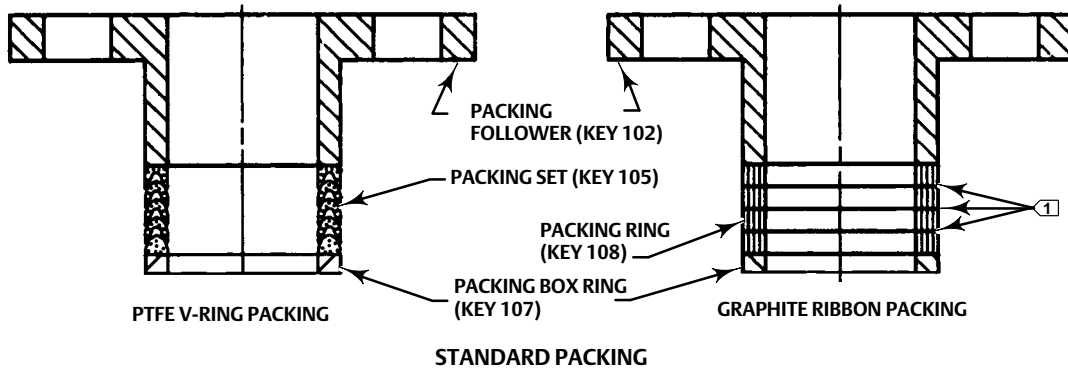

NOTE:
 [1] INCLUDES ZINC WASHERS FOR GRAPHITE RIBBON PACKING ONLY

1185895-A
 1086817-A
 4238445-B
 C0785-1

ENVIRO-SEAL GRAPHITE PACKING SYSTEM

1. Install the new packing parts (see figure 8). Install the packing follower and finger tighten the packing flange nuts onto the studs only enough to stop leakage.
2. If the valve was equipped with a bonding strap assembly (figure 5), re-install the assembly.
3. Refer to the Actuator Mounting section of this manual. If necessary, refer to the separate actuator instruction manual for adjustment procedures.
4. When the control valve is being placed into operation, check around the packing follower for leakage.

For PTFE-filled or graphite standard packing arrangements covered in this manual, leakage from the packing can often be stopped by tightening the packing flange nuts just enough to stop the leak.

CAUTION

Use caution when tightening the nuts. Overtightening the nuts can damage packing box parts and result in increased drive shaft friction.

Seal Ring Maintenance for NPS 3 through 12

Perform this procedure if the control valve is not shutting-off properly (if it is leaking downstream). It is recommended, but not required, to remove the actuator for easier handling of the valve during the following procedures.

CAUTION

During any of the following steps, do not rotate the disc past 90 degrees in the open direction. Rotating the disc past 90 degrees can damage the seal ring.

Figure 9. Retainer Ring Knock-Out Flat

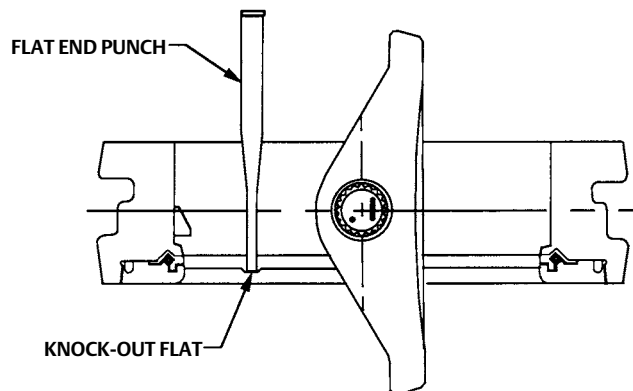

A6304

Key numbers are shown in figure 14 unless otherwise noted.

Disassembly

Refer to the Removing the Actuator section. Most maintenance procedures will require the actuator to be removed.

1. Remove the retainer ring (key 2, figure 10):

For valves with press-fit retainer rings:

- Place the valve on blocks with the seal retainer facing down. (Note: Position blocks so they do not restrict the retainer ring removal.)
- Rotate the disc to the open position as shown in figure 9.
- Locate one of the knock-out points machined on the retainer ring. Using a hammer and flat end punch on the knock-out point, pop out the retainer ring from the valve body.

CAUTION

When popping out the retainer ring, be very careful to hit only the knock-out points. Hitting anywhere else can cause non-repairable damage to the t-slot area.

- Clean all sealing surfaces and parts before re-assembly.

For valves with screwed retainer rings

- Place the valve on blocks with the seal retainer facing up.
- Remove the retainer ring screws (key 17). If necessary, use two of the retainer screws in the tapped holes in the retainer ring (key 2, figure 14) to jack the retainer ring loose from the valve body surface.

2. Remove the seal ring from the valve body seal ring slot.

For valves with PTFE seal rings, remove the spring (key 5) as it may be necessary to re-install the spring into the new PTFE seal ring.

For valves with metal seals, remove the gasket (key 16) from the valve body surface, and discard it as replacement is recommended.

3. If it is necessary to replace the disc, drive shaft, and the bearings, refer to that section below before proceeding with the assembly procedures for the seal ring and retainer. The seal ring could be damaged if it is in place while removing the disc.

Assembly

Place the valve on blocks with the seal retainer facing up. If the replacement disc, shaft, and bearings have not been installed in the valve body, go to the proper assembly procedures to install them.

CAUTION

Do not install the seal ring without the disc being in place. The seal ring could be damaged while installing the disc.

⚠ WARNING

Do not lubricate parts when used in oxygen service, or where the lubrication is incompatible with the process media. Any use of lubricant can lead to the sudden explosion of media due to the oil/oxygen mixture, causing personal injury or property damage.

Figure 10. Disc Rotation Indication

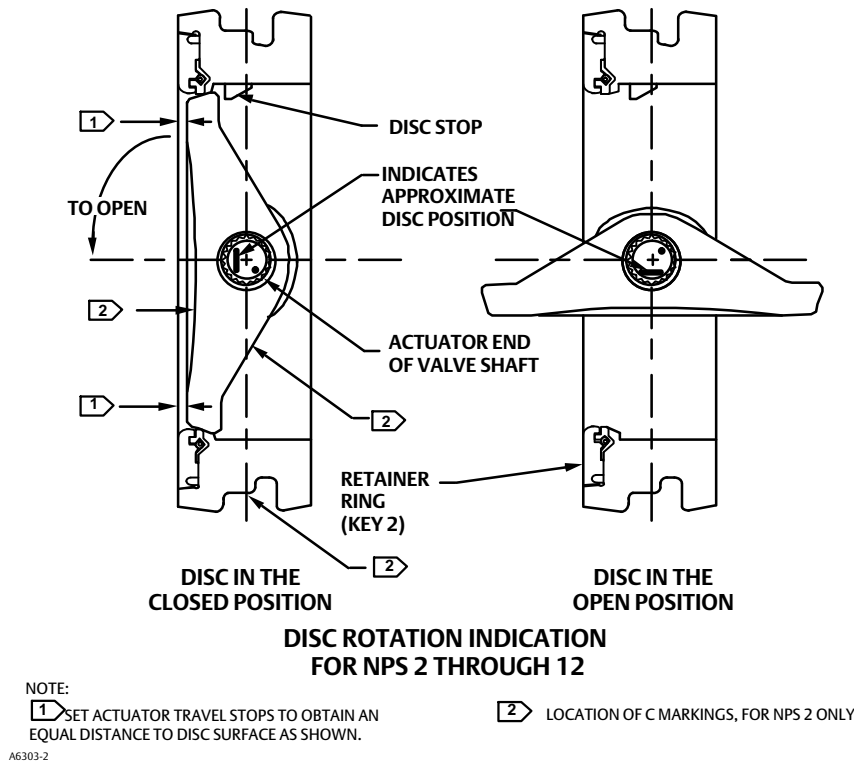

CAUTION

Do not rotate the disc past 90 degrees in the open direction. Rotating the disc past 90 degrees can damage the seal ring or other component parts.

Note

PTFE, NOVEX, and Phoenix III seal rings used in other valve types are not interchangeable with seal rings used in the 8560 valve. The 8560 seal rings are not interchangeable with seal rings in any other valve type. To order seal rings for this valve, provide the serial number on the valve.

1. Installing PTFE seal rings:

- a. The valve disc should be open while installing the seal ring. If not, rotate the disc to the open position as shown in figure 10.
- b. Hook the spring ends together, insert the spring (see figure 11) into the groove in the seal ring, and work the spring into the recess in the PTFE seal ring.
- c. Install the seal ring assembly into the slot in the valve body as shown in figure 11. Refer to Installing the retainer ring steps below.

Figure 11. Available Seal Configurations

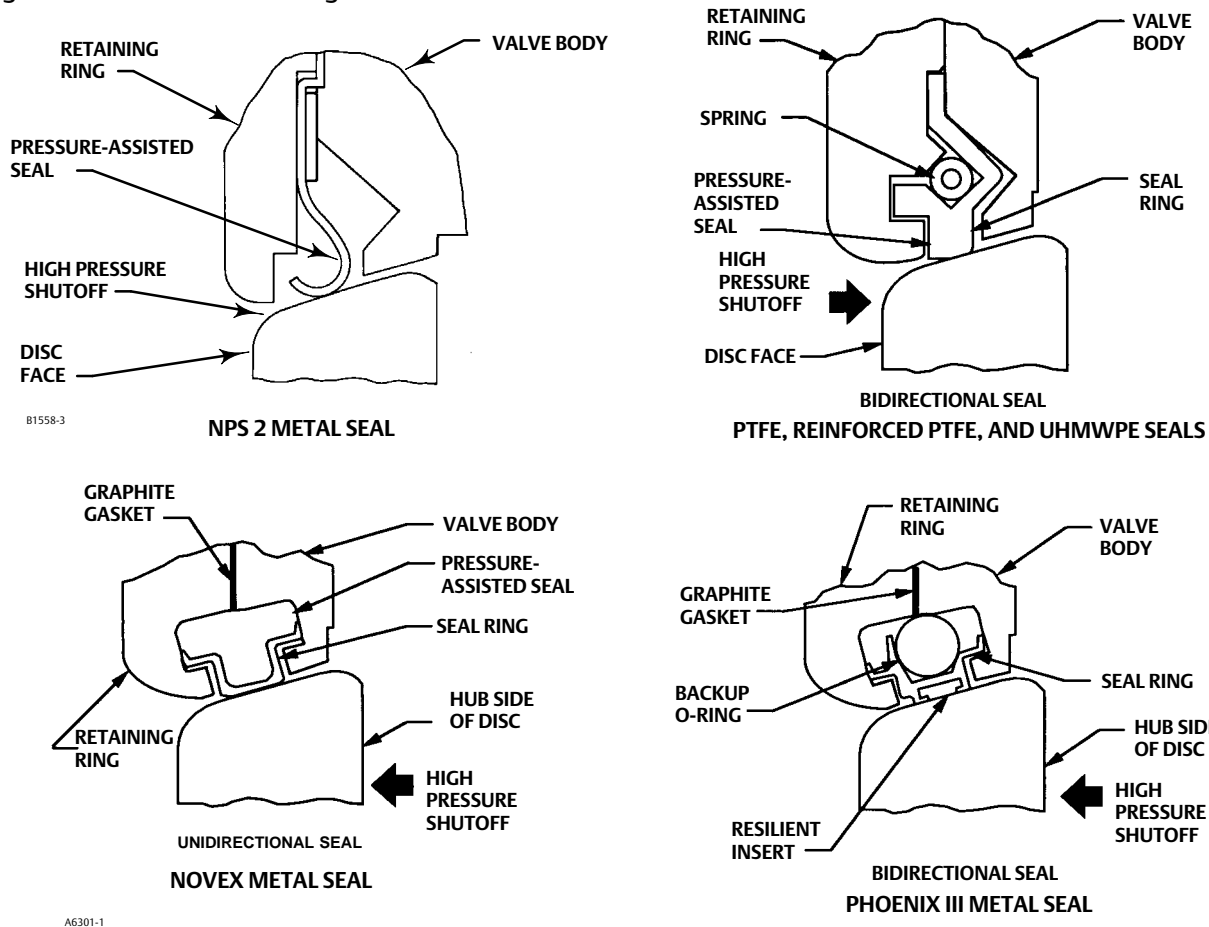

2. Installing metal seals:

Note

For metal seals only, it may be necessary to apply a dry film lubricant or equivalent moly disulfide to the sealing surfaces of the disc, seal and the seal retainer groove. Prior to applying the lubricant the sealing surfaces should be inspected for injurious defects. Surfaces can be polished using a scuffing hand pad or equivalent. The edge of the seal that contacts the retaining ring groove should also be inspected and polished if necessary.

Note

Use the appropriate lubrication on parts when used in oxygen service, or where the lubrication is incompatible with the process media.

- a. Rotate the disc to the open position as shown in figure 10.

CAUTION

The seal ring will be damaged if the disc remains in the closed position during seal and retainer ring assembly.

- b. Install the metal seal ring assembly (see figure 11).
3. Installing the retainer ring:
- a. Valves with PTFE seal rings do not require a retainer ring gasket (key 16).
 - b. Valves with metal seals require a retainer ring gasket (key 16).

CAUTION

When handling the new retainer ring gasket, be sure to avoid kinking, cracking, or breaking the gasket. Damage to the gasket can cause leakage between the seal retainer and valve body.

- c. Lay the gasket (key 16) down so that it is accurately centered on the valve body.
4. For valves with press-fit retainer rings
- a. Wipe excessive oil off the retainer ring outside diameter, and off the retainer counterbore in the valve body.
 - b. Rotate the disc to the open position.
 - c. Lay the retainer ring on the valve body.
 - d. Use a press, or a soft-faced hammer to press the retainer ring into its groove in the valve body.

CAUTION

It takes a considerable amount of force with a hammer to drive the retainer ring into place. Be sure not to damage retainer ring surfaces when installing the ring.

- e. The retainer ring is properly seated when the face of the retainer ring is flush with the face of the valve body.
- f. To ensure proper seal performance for metal seals, you may need to use the hammer to drive the disc open for the first few times. When closing the valve, use the C-clamps discussed in the next few steps.

CAUTION

Do not damage the gasket seating surfaces on either the valve body or the retainer ring when installing or removing the C-clamps. Protect the gasket surface by using a soft material between the clamp and valve body/retaining ring serrations to avoid damage.

- g. Use three C-clamps to hold the retainer in place. Locate one of the C-clamps near the travel stop in the valve body, and the other two at 120 degrees from the stop.
 - h. When cycling the disc for the first three times, use a dead-blow hammer with a soft head to drive the disc closed. Also, you may need to use the hammer to drive the disc open for the first few times.
5. For valves with screwed retainer rings
- a. Match the retainer ring with the holes in the valve by punching two holes in the gasket to locate where the screw holes are in the valve.
 - b. Lay the retainer ring over the gasket, while lining it up with the punched holes. Also insert two retainer screws (key 17). Finger tighten them.
 - c. Press the remaining screws through the gasket material and finger tighten them. When all retainer screws are in place, tighten them in a crisscross pattern.
 - d. The retainer ring is properly seated when the retainer face is nearly flush with the face of the valve.
6. Turn the disc into and out of the seal ring several times, to help break in the seal and reduce actuator torque requirements during adjustment.
7. If replacing the packing, remove all packing parts from the valve body. Upon re-assembly of the valve, refer to the Packing Maintenance procedures to replace the packing.

Seal Ring Maintenance for NPS 2

This procedure is to be performed if the control valve is not shutting off properly (that is, leaking downstream). This procedure does not require removing the actuator from the valve body. Part key numbers are shown in figure 15.

⚠ WARNING

Refer to the **WARNING** at the beginning of the Maintenance section in this instruction manual.

1. Isolate the control valve from line pressure, and relieve pressure from the valve body. Shut off and disconnect all lines from the power actuator.

⚠ WARNING

The edges of a rotating disc have a shearing effect that may result in personal injury. To help prevent such injury, stay clear of the disc edges when rotating the disc (key 3).

CAUTION

Damage to the disc (key 3) may occur if the disc is not closed when the valve is being removed from the pipeline. If necessary, pressure the actuator temporarily to retain the disc in the closed position while removing the valve from the pipeline.

2. Unscrew the flange bolts, and remove the valve from the pipeline.

3. Unscrew the machine screws (key 17), and remove the seal retainer (key 2). Also remove the retainer clip (key 30).
4. Remove the seal ring or seal ring assembly (key 4). The spring (key 5) is removed with a PTFE seal ring.
5. For 316 stainless steel seal ring assemblies, replace the gaskets (key 4C) if the entire seal ring assembly is not replaced. Scrape off the old gaskets from both sides of the seal ring and the seal ring sides of the valve body (key 1) and seal retainer. Clean the gasket surfaces.
6. Reconnect or mount the actuator (if it was removed) before proceeding.

For an actuator with adjustable travel, also adjust the actuator before proceeding. This is necessary due to the measurements that must be made during the actuator adjustment process.

Refer to the Actuator Mounting section of this manual and to the separate actuator instruction manual for mounting and adjusting instructions.

7. The valve should be closed during seal ring installation to permit accurate centering of the seal. To install the new seal ring:

For a PTFE seal, if the spring (key 5) was disassembled, hook the spring ends together. Work the spring into the recess in the seal ring (key 4). Install the seal ring and spring assembly into the recess in the valve body as shown in figure 15. For a complete 316 stainless steel seal ring assembly, install the seal ring assembly as shown in figure 15.

CAUTION

New seal ring gaskets (key 4C) are very fragile and must be handled very carefully to avoid gasket kinking, cracking, or breakage that can cause leakage between the seal ring, seal retainer, and valve body. To avoid gasket damage, make sure that the valve body is lying flat so that the gaskets do not shift before the following steps are completed.

8. For a 316 stainless steel seal ring on which the gaskets will be replaced, lay the following parts down in order so that they are accurately centered on the valve body: one new gasket; the seal ring oriented as shown in figure 15; and the second new gasket.
9. Attach the seal retainer and, if used, the retainer clips and washers to the valve body and secure with the machine screws. Tighten the machine screws evenly so as not to crack or break the 316 stainless steel seal ring gaskets, if used.

Be certain the disc is closed before installing the valve according to the Installation section of this instruction manual.

Disc, Drive Shaft, and Bearing Maintenance for NPS 3 through 12

This procedure is to be performed when replacing the valve disc, drive shaft, taper pins, hollow pins, and bearings due to wear or damage to one or more component parts.

Key numbers are shown in figure 14 unless otherwise noted.

Disassembly

1. Loosen the packing flange nuts (key 101). This allows the drive shaft (key 8) to turn without the friction caused by the packing.
2. Remove the actuator using the steps provided in the Removing the Actuator procedures above, and remove the seal ring using the steps provided in the seal ring maintenance procedures above.
3. Place the valve on a flat working surface with the seal ring slot facing down.
4. Use blocks to raise the valve body high enough to allow the disc to be rotated to the fully open position (see figure 10).

5. Rotate the disc (key 3) to the fully open position.
6. Locate the small ends of the taper pins. Drive the two taper pins (key 10) out towards the larger end of the pins. (Note: Attempting to drive the taper pins in the opposite direction only tightens the pins.) Also, remove the hollow pins (key 9) from the disc/shaft connection using the tool shown in figure 13.

Note

Make the tools for removal and installation of the hollow pin shown in figure 13.

7. Unscrew and remove the packing flange nuts (key 101), and the packing flange (key 102).

⚠ WARNING

Once the shaft has been removed in the following step, the disc may fall out of the valve body cavity. To avoid personal injury and property damage, support the disc to prevent it from falling as the shaft is being removed.

8. Pull the shaft out of the valve body, and remove the disc (key 3) from the valve body bore.
9. If the packing is to be replaced, remove all the packing parts from the valve body. Upon re-assembly of the valve, refer to the Packing Maintenance procedures to replace the packing parts.
10. Remove both of the bearings (key 6) from the valve body. For CL150 valves with metal bearings, refer to the following note.

Note

CL150 valves with metal bearing assemblies have three parts. A disc spacer, bearing, and bearing spacer (keys 7, 6, and 13) are used in place of a single piece bearing. The disc spacers may fall out of the valve when the disc is removed. If needed for re-assembly, retain disc spacer and bearing spacer parts.

11. Clean all the sealing surfaces and parts, and inspect and/or obtain replacements before assembly.

Assembly

1. Install the bearings (key 6):

When installing the bearings in the opposite side of the valve body bore, repeat the following procedures.

- For PEEK/PTFE CL150 and CL300 metal bearings, one piece bearings: Position the bearing edge to match the valve body bore, and insert the one piece bearing/disc spacer into the bearing bore with the bearing tab facing away from the disc stop as shown in figure 12.
- For CL150 metal bearings, three piece assemblies: Bearings for CL150 valves are an assembly made up of three parts: disc spacer, bearing, and bearing spacer (keys 7, 6, and 13) as shown in the metal bearing detail shown in figure 14.
 - a. Install the bearing spacer (key 13) into the bearing bore.
 - b. Install the bearing into the bearing bore until the bearing is flush with the valve body bore.

- c. When installing the disc spacer (key 7) position the curved side to match the valve body bore, and position it with the tab on the spacer pointing away from the disc stop as shown in figure 12.

Note

The disc spacer will have to be held in place when installing the disc and inserting the shaft through the valve body, bearings, bearing spacer, and disc. To help hold the spacer in place, apply some lubricant.

CAUTION

To avoid product damage, protect the disc sealing surfaces while inserting the disc into the valve body bore.

2. Position the disc to be certain that the holes in the disc are towards the actuator side of the valve. Carefully insert the disc into the valve body bore while protecting the disc sealing surfaces.
3. Install the shaft (key 8):
 - For PEEK/PTFE CL150 and CL300 metal bearings, one piece bearings: Slide the shaft through the valve body bore and bearing. Position the disc as stated above and slide the shaft through the disc and outer bearing. Refer to step 4 below.
 - For CL150 metal bearings, three piece assemblies: Slide the shaft into the valve body bore and bearing spacer. Position the disc spacer as stated above and hold it in place. Slide the shaft through the bearing and into the disc. Position the second disc spacer, and hold it in place. Slide the shaft through the disc spacer and into the outer bearing.

Installing the hollow pin and taper pin

4. Place the valve body on a flat working surface with the slot for the seal ring facing *up*. Block the valve body high enough to allow the disc to be rotated into the open position as shown in figure 13.

Figure 12. Orientation of Bearing/Spacer Tab

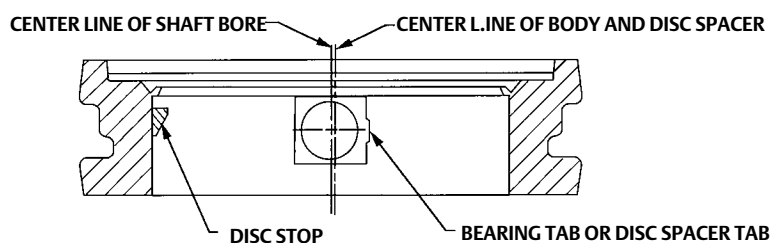

A6357-1

5. Rotate the disc to the open position. On the end of the drive shaft, locate the disc position mark on the end of the drive shaft. Rotate the shaft until it is in the appropriate disc position as shown in figure 13.

Note

Make sure the taper and hollow pins are free of particulate matter before continuing.

6. Line-up both holes in the disc hub with the holes in the drive shaft (key 8). (Note: The hole in the drive shaft is off-set to prevent the shaft from being installed in the wrong position. Be sure the hole in the shaft is lined up with the hole in the disc hub.)
7. Insert the hollow pins (key 9), into the disc hub as shown in figure 13.

Using the tool shown in figure 13, tap the hollow pin down into the disc hub and shaft until the hollow pin bottoms on the stop in the disc.

8. Insert the taper pins (key 10) into the hollow pins. Using a flat end punch, drive the taper pins into the hollow pins until solid contact is felt. Anchor the pins in place by staking them with a center-punch and hammer. The disc and shaft should rotate smoothly.
9. Install the seal ring assembly using the appropriate instructions in the Seal Ring Maintenance procedures.
10. Install the packing parts using the appropriate instructions provided in the Packing Maintenance procedures. Refer to the Actuator Mounting procedures before installing the valve in the pipeline.

Disc, Shaft Assembly and Bearing Maintenance for NPS 2

This procedure is to be performed to replace the valve disc, shaft, and taper pin assembly if the disc does not rotate in response to rotation of the actuator end of the valve shaft. Unless otherwise indicated, part key numbers are shown in figure 15.

Disassembly

1. Remove the seal ring according to steps 1 through 5 of the Replacing Seal Ring section.

CAUTION

Use a wheel puller to separate actuator parts from the valve shaft. Driving the parts off the valve shaft could move the valve bearings and disc away from the centered position, damaging the disc and valve body.

2. Remove the cap screws and, if used, the hex nuts. Remove the clamp if the strap is used. Remove the actuator from the valve body while referring to the separate actuator instruction manual for assistance.
3. Rotate the disc (key 3) to the fully open position.
4. Locate the half of the disc that has two C markings cast into it as shown in figure 10. Drive the two taper pins (key 3C) out toward the C-marked side of the disc. Attempting to drive the taper pins in the opposite direction only tightens the pins.
5. Unscrew and remove the packing flange nuts (key 101), packing followers (key 114), and packing flanges (key 102) if used, from both sides of the valve.

⚠ WARNING

Once the shaft has been removed in the following step, the disc may fall from the valve. To avoid personal injury and disc damage, support the disc to prevent it from falling as the shaft is being removed.

6. Pull the shaft out through the actuator side of the valve.
7. Remove the disc from the valve body.
8. Remove the packing rings (key 108), the packing washers (key 115) if used, and the packing box ring (key 107).

9. If either of the bearings (key 6) require maintenance or replacement, remove them.

CAUTION

When replacing a valve disc or shaft, a new disc/shaft/taper pin assembly (key 3) should be used. Using a new disc with a used shaft requires drilling and reaming new taper pin holes in the shaft. The extra set of taper pin holes weakens the shaft and may cause it to fail in service.

10. Clean the packing boxes and metal packing box parts.

Assembly

1. Drop in the new bearings. Make sure to orient the tab in the bearing with the slot in the seal.
2. Insert the disc into the valve body. Be certain the taper pin holes in the disc are on the actuator side of the valve. Also be certain the letter C stamped on either face of the disc is on the same side of the valve as the letter C stamped on the outside of the valve (figure 10).
3. Slide the shaft through the valve body and disc.
4. Install the disc and spacers into the valve body. Insert the shaft into the valve body and through the disc.
5. Slide the shaft all the way into the valve body.
6. To ensure that the direction of taper in the shaft taper pin holes matches that of the disc taper pin holes, temporarily install the packing follower (key 114) or, if used, the packing flange (key 102) with rotation tag (key 19). With the disc fully opened, rotate the shaft until the line on the end of the shaft indicates the open position, as shown in figure 10. Insert the taper pins (key 3C), small end first, into the taper pin holes on the C-marked side of the disc. Do not drive in the pins. Remove the packing follower or flange.

Actuator Mounting

Re-install the seal ring and packing rings using the appropriate procedures before installing the actuator on the valve. Mount the actuator on the valve body in accordance with the instructions in the actuator instruction manual and this section.

In the Packing Maintenance/Removing the Actuator steps, you should have noted the position of the mark on the end of the valve shaft, and its relationship to the actuator shaft. If not, determine the configuration needed to match your application.

Be certain that the disc is rotating counterclockwise to open when viewed from the actuator side of the valve, and that the disc is not rotated beyond its limits.

1. Orientate the valve drive shaft correctly to match the actuator or handlever position, and install it into the actuator and actuator lever arm until the mounting pads mate with each other.
2. Tighten the actuator-mounting cap screws (key 14, figure 14) to the appropriate bolt torque from table 7.

CAUTION

The valve disc stop, in the valve body bore is not to be used as a power actuator travel stop (see figure 9). Use the actuator travel stops to limit the rotation of the valve disc. It is possible to damage the valve component parts if full actuator thrust is applied to the valve disc stop.

For actuators with an adjustable turnbuckle, such as the 1051, 1052, or 1061 actuator, the turnbuckle must be adjusted so that the valve is closed (determined by measuring as shown in figure 7) when the diaphragm or piston is against the actuator travel stop.

For manually operated actuators or actuators without adjustable linkage, such as the 1066 or 1066SR actuator, make certain that the travel of the actuator stops before the disc rotates past the closed position.

REMOVAL TOOL DIMENSIONS				
Shaft Diameter	ØA	B	C	ØD
mm				
12.7	3.91	28.43	6.35	4.19
15.88	4.60	38.10	7.87	23.37
19.05	5.13	44.45	9.65	5.41
25.4	7.00	59.44	12.70	7.26
31.75	9.50	76.20	19.05	9.78
38.1	10.82	88.90	19.05	11.10
44.45	12.37	114.30	22.35	12.65
Inch				
1/2	0.154	1.12	0.25	0.165
5/8	0.181	1.50	0.31	0.192
3/4	0.202	1.75	0.36	0.213
1	0.275	2.34	0.50	0.286
1-1/4	0.374	3.00	0.75	0.385
1-1/2	0.426	3.50	0.75	0.437
1-3/4	0.487	4.50	0.88	0.498

INSTALLATION TOOL DIMENSIONS					
Shaft Diameter	ØA	ØB	ØC	D	E
mm					
12.7	12.7	3.68	6.35	127.0	4.83
15.88	12.7	4.57	7.62	127.0	4.83
19.05	12.7	5.23	8.89	127.0	4.83
25.4	12.7	7.00	10.41	127.0	4.83
31.75	19.05	10.00	13.59	146.0	6.35
38.1	19.05	11.56	15.24	146.0	6.35
44.45	19.05	31.21	16.76	146.0	6.35
Inch					
1/2	0.50	0.145	0.250	5.00	0.19
5/8	0.50	0.180	0.300	5.00	0.19
3/4	0.50	0.206	0.350	5.00	0.19
1	0.50	0.275	0.410	5.00	0.19
1-1/4	0.75	0.395	0.535	5.75	0.25
1-1/2	0.75	0.455	0.600	5.75	0.25
1-3/4	0.75	0.520	0.660	5.75	0.25

Figure 13. Taper Pin and Hollow Pin Removal and Installation

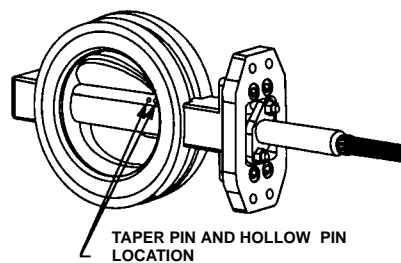
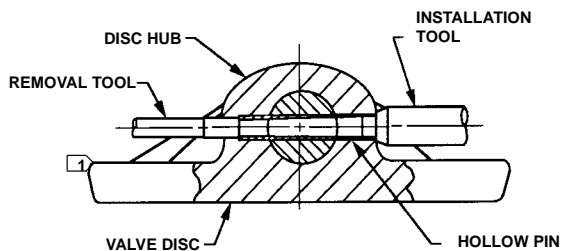
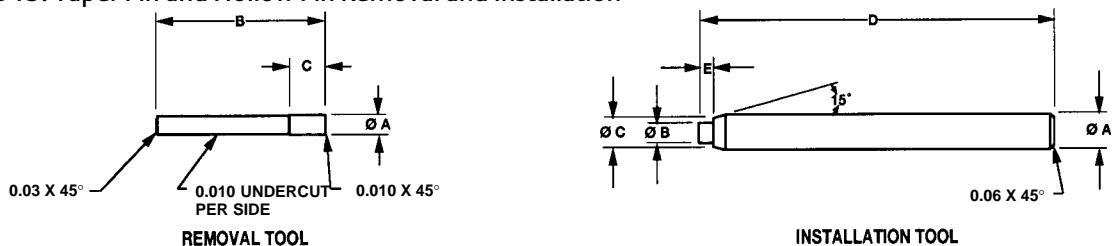

NOTE:
 1. REMOVE THE HOLLOW PIN FROM THIS SIDE OF THE DISC HUB.
 INSTALL THE HOLLOW PIN FROM THE OPPOSITE SIDE OF DISC HUB.

A6356

Table 7. Recommended Bolt Torques for Actuator/Mounting Cap Screws and Nuts

VALVE SIZE, NPS	RECOMMENDED BOLT TORQUE	
	N•m	lb•ft
CL150 Valves		
2 ⁽¹⁾ , 3, 4, 6, & 8	88	65
10 & 12	135	100
CL300 Valves		
2, 3, 4, & 6	88	65
8 & 10	135	100
12	183	135

1. Value for NPS 2 also applies to CL600 Valves.

Note

To obtain proper shutoff, the closed position of the A41/8560 valves must be set with the disc parallel to the retaining ring. Don't use the disc stop to set the actuator travel stops.

3. Adjust the actuator travel stop to limit the open and closed positions of the valve disc. (If necessary, refer to the actuator instruction manual for more information about adjustments.) Do not use the disc stop as a actuator travel stop as discussed in the **Caution** above.
4. For actuators with adjustable turnbuckles, adjust the turnbuckle to bring the disc to the fully closed position at the end of the actuator stroke. If necessary, refer to the appropriate actuator instruction manual for assistance.
5. If using a manual handwheel or handlever actuator, refer to the appropriate actuator instruction manual for mounting positions and adjustments.
6. To determine the fully closed disc position (zero degrees of disc rotation), measure the distances between the positions on the disc face as shown in figure 10. Use the actuator to rotate the disc while re-checking the two measurements. Repeat adjustment until the two measurements are equal.

Parts Ordering

When corresponding with your [Emerson sales office](#) or Local Business Partner about this equipment, always mention the valve serial number.

▲ WARNING

Use only genuine Fisher replacement parts. Components that are not supplied by Emerson Automation Solutions should not, under any circumstances, be used in any Fisher valve, because they may void your warranty, might adversely affect the performance of the valve, and could cause personal injury and property damage.

ENVIRO-SEAL Packing Arrangements

Retrofit kits and repair kits are listed in the tables below. For additional parts and repair information, refer to the ENVIRO-SEAL Packing System for Rotary Valves instruction manual ([D101643X012](#)) or contact your Emerson sales office for assistance.

Repair Kits for ENVIRO-SEAL Packing

Repair Kits include replacement parts for key 105 and 106 for the shaft diameters listed below.

ENVIRO-SEAL Packing Repair Kits

SHAFT DIAMETER ⁽¹⁾	
mm	Inches
12.7	1/2
15.9	5/8
19.1	3/4
25.4	1
31.8	1-1/4
38.1	1-1/2
Parts Included in Kit	
Key	Description
105	Packing set
106	Anti-extrusion washer

1. Diameter through the packing box.

Retrofit Kits for ENVIRO-SEAL Packing

Retrofit kits include new parts for the key numbers listed in the table below (see figure 8 for part locations).

ENVIRO-SEAL Packing Retrofit Kits

SHAFT DIAMETER ⁽¹⁾	
mm	Inches
12.7	1/2
15.9	5/8
19.1	3/4
25.4	1
31.8	1-1/4
38.1	1-1/2
Parts Included in Kit	
Key	Description
100	Packing stud
101	Packing nut
102	Packing flange
103	Spring pack ass'y
105	Packing set
106	Anti-extrusion washer
107	Packing box ring
111	Tag
112	Tie cable

1. Diameter through the packing box.

Parts List

Note

Part numbers are shown for recommended spares only. For part numbers not shown, contact your [Emerson sales office](#) or Local Business Partner.

Key	Description	Part Number
1	Valve Body If you need a new valve body, order by valve size, serial number and desired material.	
2*	Seal Retainer	See following table
3	Valve Disc, NPS 3 through 12	
3	Disc/Shaft Assembly, NPS 2 only	
3A	Shaft, NPS 2 only	
3B	Valve Disc, NPS 2 only	
3C	Taper Pin, NPS 2 only (2 req'd)	
4*	Seal Ring	
	PTFE	
	NPS 2	75B0387X012
	NPS 3	75B0020X012
	NPS 4	75B0042X012
	NPS 6	75B0003X012
	NPS 8	75B0311X012
	NPS 10	75B0312X012
	NPS 12	75B0313X012
	UHMWPE	
	NPS 2	75B0387X022
	NPS 3	75B0020X022
4*	Seal Ring (continued)	
	NPS 4	75B0042X022
	NPS 6	75B0003X022
	NPS 8	75B0311X022
	NPS 10	75B0312X022
	NPS 12	75B0313X022
	Glass filled PTFE	
	NPS 2	75B0387X032
	NPS 3	75B0020X032
	NPS 4	75B0042X032
	NPS 6	75B0003X032
	Glass filled PTFE	
	NPS 8	75B0311X032
	NPS 10	75B0312X032
	NPS 12	75B0313X032
	NOVEX S31600 SST	
	NPS 2	17A7544X022
	NPS 3	75B1108X012
	NPS 4	75B1109X012
	NPS 6	75B1110X012
	NPS 8	75B0341X012
	NPS 10	75B1112X012
	NPS 12	75B1113X012
	NOVEX S21800	
	NPS 3	75B1108X022
	NPS 4	75B1109X022
	NPS 6	75B1110X022
	NPS 8	75B0341X022
	NPS 10	75B1112X022
	NPS 12	75B1113X022

Key	Description	Part Number	Key	Description	Part Number
	Phoenix III S31600/PTFE			NPS 6	
	NPS 3	75B1115X012		Class 150	75B1136X032
	NPS 4	75B1116X012		Class 300	75B1101X012
	NPS 6	75B1117X012		NPS 8	
	NPS 8	75B0351X012		CL150	75B1136X042
	NPS 10	75B0337X012		CL300	75B1102X012
	NPS 12	75B0339X012		NPS 10	
4C	Gasket, Included in 2-inch NOVEX S31600 SST Seal Ring			CL150	75B1136X052
				CL300	75B1103X012
5*	Spring			NPS 12	
	S31600 SST			CL150	75B1136X062
	NPS 2	12A9022X012		CL300	75B1104X012
	NPS 3	75B0021X012	7*	Disc Spacer (2 req'd)	
	NPS 4	75B0043X012		w/ Metal Bearings, CL150 only	
	NPS 6	75B0004X012		NPS 3	75B1176X012
	NPS 8	75B0012X012		NPS 4	75B1176X022
	NPS 10	75B0029X012		NPS 6	75B1176X032
	NPS 12	75B0036X012		NPS 8	75B1176X042
	R30003			NPS 10	75B1176X052
	NPS 2	12A9022X062		NPS 12	75B1176X062
	NPS 3	75B0021X052	8*	Drive Shaft	see following table
	NPS 4	75B0043X052	9*	Hollow Pin	See following table
	NPS 6	75B0004X052	10*	Taper Pin	See following table
	NPS 8	75B0012X052	11	Adaptor Plate	
	NPS 10	75B0029X052	12	Socket Head Cap Screw (4 req'd)	
	NPS 12	75B0036X052	13*	Bearing Spacer (2 req'd)	
6*	Bearing (2 req'd)			w/ Metal Bearings, CL150 only	
	PEEK/PTFE			NPS 3	75B1137X012
	NPS 2	75B0620X012		NPS 4	75B1137X022
	NPS 3			NPS 6	75B1137X032
	CL150	75B1066X012		NPS 8	75B1137X042
	CL300	75B1073X012		NPS 10	75B1137X052
	NPS 4			NPS 12	75B1137X062
	CL150	75B1067X012	14	Hex Head Cap Screw, Steel (4 req'd)	
6*	Bearing (2 req'd) (continued)		14	Stud Bolt, SST (4 req'd)	
	CL300	75B1074X012	15*	Backup Ring	See following table
	NPS 6		16*	Gasket, Graphite	
	CL150	75B1068X012		w/ Metal and Phoenix III seals	
	CL300	75B1075X012		NPS 3	75B1124X022
	NPS 8			NPS 4	75B1124X032
	CL150	75B1069X012	16*	Gasket, Graphite (continued)	
	CL300	75B1076X012		NPS 6	75B1124X042
	NPS 10			NPS 8	75B1545X012
	CL150	75B1070X012		NPS 10	75B1545X022
	CL300	75B1077X012		NPS 12	75B1545X032
	PEEK/PTFE		17	Hex Socket Cap Screw	
	NPS 12			NPS 2 (2 req'd)	
	CL150	75B1071X012		NPS 3 (14 req'd for single flange-style valve)	
	NPS 12			NPS 4 and 6 (16 req'd for single flange-style valve)	
	CL300	75B1078X012		NPS 8 through 12 (20 req'd for single flange-style valve)	
	316/Nitride		18	Mfg Label	
	NPS 2	75B0599X012	19	Drive Screw, w/ nameplate	
	NPS 3		20	Hex Nut (4 req'd)	
	CL150	75B1136X012	21	Nameplate	
	CL300	75B1099X012	22	Lead Seal & Wire	
	NPS 4		23	Bottom Cap, 12-inch only	
	CL150	75B1136X022	24	Bottom Cap Stud, 12-inch only	
	CL300	75B1100X012	25	Bottom Cap Hex Nut, 12-inch only	
			27	Bottom Cap Gasket, 12-inch only	
			29	Flow Arrow, 3- through 12-inch	
			30	Retainer Clip, 2-inch only	

Packing

Note

Parts in this section are listed by shaft diameter (inches).

SHAFT DIAMETER	VALVE SIZE	
	CL150	CL300
1/2	2 & 3	2
5/8	4	3
3/4	6	4
1	8	6
1-1/4	10	8
1-1/2	12	10
1-3/4	---	12

Key Description

100	Packing Stud (2 req'd)	
101	Packing Nut (2 req'd)	
102	Packing Flange	
103	Spring Pack Assembly, ENVIRO-SEAL & FFKM	
105*	Packing Set	
	PTFE/Carbon filled PTFE	
	1/2 inch	12A9016X022
	5/8 inch	1R5795X0012
	3/4 inch	12A8995X022
	1-inch	12A8832X022
	1-1/4 inch	12A8951X022
	1-1/2 inch	12A8935X022
	1-3/4 inch	12A9057X022
	ENVIRO-SEAL PTFE	
	1/2 inch	12B7053X012
	5/8 inch	12B7402X012
	3/4 inch	12B7414X012
	1-inch	12B7438X012
	1-1/4 inch	12B7450X012
	1-1/2 inch	12B7462X012
	1-3/4 inch	14B3049X012
105*	Packing Set (continued)	
	ENVIRO-SEAL Graphite	
	1/2 inch	13B8816X012
	5/8 inch	13B8816X032
	3/4 inch	13B8816X052
	1-inch	13B8816X092
	1-1/4 inch	13B8816X112
	1-1/2 inch	13B8816X142
	1-3/4 inch	13B8816X152
	FFKM/PTFE	
	1/2 inch	24B6254X012
	5/8 inch	24B6254X022
	3/4 inch	24B6254X032
	1-inch	24B6254X052
	1-1/4 inch	24B6254X062
	1-1/2 inch	24B6254X072
	FFKM/CRCC	
	1/2 inch	24B6255X012
	5/8 inch	24B6255X022
	3/4 inch	24B6255X032
	1-inch	24B6255X052

Key	Description	Part Number
	1-1/4 inch	24B6255X062
	1-1/2 inch	24B6255X072
106*	Anti-Extrusion Ring, ENVIRO-SEAL PTFE (2 req'd)	
	1/2 inch	12B7054X012
	5/8 inch	12B7406X012
	3/4 inch	12B7418X012
	1-inch	12B7442X012
	1-1/4 inch	12B7454X012
	1-1/2 inch	12B7466X012
	1-3/4 inch	14B3045X012
107*	Packing Box Ring	
	Standard Packing (by trim material)	
	1/2 inch	
	S31600	16A6082X012
	N08020	16A6082X042
	N10276	16A6082X092
	N04400	16A6082X082
	5/8 inch	
	S31600	16A6083X012
	N08020	16A6083X052
	N10276	16A6083X082
	N04400	16A6083X102
	3/4 inch	
	S31600	16A6084X012
	N08020	16A6084X082
	N10276	16A6084X072
	N04400	16A6084X032
	1-inch	
	S31600	16A6085X012
	N08020	16A6085X042
	N10276	16A6085X092
	N04400	16A6085X082
	1-1/4 inch	
	S31600	16A6086X012
	N08020	16A6086X042
	N10276	16A6086X092
	N04400	16A6086X082
	1-1/2 inch	
	S31600	16A6087X012
	N08020	16A6087X102
	N10276	16A6087X092
	N04400	16A6087X082
	1-3/4 inch, S31600 only	12A9058X012
107*	Packing Box Ring (continued)	
	ENVIRO-SEAL Packing	
	1/2 inch	16A6082X012
	5/8 inch	16A6083X012
	3/4 inch	16A6084X012
	1-inch	16A6085X012
	1-1/4 inch	16A6086X012
	1-1/2 inch	16A6087X012
	1-3/4 inch	12A9058X012
	FFKM	
	1/2 inch	14B6188X012
	5/8 inch	14B6190X012
	3/4 inch	14B6191X012
	1-inch	14B6195X012
	1-1/4 inch	14B6197X012
	1-1/2 inch	14B6198X012
108*	Packing Ring, Graphite Ribbon (4 req'd)	
	1/2 inch	12A9134X012
	5/8 inch	12A9135X012
	3/4 inch	12A9136X012
	1-inch	12A9137X012

*Recommended spare parts

Key	Description	Part Number	Key	Description	Part Number
	1-1/4 inch	12A9138X012		1/2 inch	14A8362X012
	1-1/2 inch	12A9139X012		5/8 inch	14A9771X012
	1-3/4 inch	12A9140X012		3/4 inch	14A8363X012
111	Tag			1-inch	14A8365X012
114	Packing Follower			1-1/4 inch	14A8366X012
115*	Packing Washer, Graphite Ribbon (3 req'd)			1-1/2 inch	14A8367X012
				1-3/4 inch	14A9772X012

Key 2* . Seal Retainer

VALVE STYLE	VALVE SIZE, NPS	MATERIAL					
		Steel	S31600 SST	S31700 SST	N08020	N10276	N04400
PTFE Seal Ring							
Wafer	2	75B0385X012	75B0385X022	75B0385X042	75B0385X052	75B0385X062	75B0385X072
	3	75B0019X012	75B0019X022	75B0019X032	75B0019X042	75B0019X062	75B0019X052
	4	75B0041X012	75B0041X022	75B0041X032	75B0041X042	75B0041X062	75B0041X052
	6	75B0002X012	75B0002X022	75B0002X032	75B0002X042	75B0002X062	75B0002X052
	8	75B0010X012	75B0010X022	75B0010X032	75B0010X042	75B0010X062	75B0010X052
	10	75B0027X012	75B0027X022	75B0027X032	75B0027X042	75B0027X062	75B0027X052
	12	75B0034X012	75B0034X022	75B0034X032	75B0034X042	75B0034X062	75B0034X052
NOVEX and Phoenix III Seal Ring							
Wafer	2	21B4667X012	21B4667X022	---	---	---	---
	3	75B1040X012	75B1040X072	75B1040X082	---	---	---
	4	75B1041X012	75B1041X072	75B1041X082	---	---	---
	6	75B1042X012	75B1042X072	75B1042X082	---	---	---
	8	75B1539X012	75B1539X022	75B1539X032	---	---	---
	10	75B1540X012	75B1540X022	75B1540X032	---	---	---
	12	75B1541X012	75B1541X022	75B1541X032	---	---	---
PTFE Seal Ring							
Single Flange	3	75B0085X012	75B0085X022	75B0085X032	75B0085X042	75B0085X062	75B0085X052
	4	75B0078X012	75B0078X022	75B0078X032	75B0078X042	75B0078X062	75B0078X052
	6	75B0050X012	75B0050X022	75B0050X032	75B0050X042	75B0050X062	75B0050X052
	8	75B0060X012	75B0060X022	75B0060X032	75B0060X042	75B0060X062	75B0060X052
	10	75B0067X012	75B0067X022	75B0067X032	75B0067X042	75B0067X062	75B0067X052
	12	75B0074X012	75B0074X022	75B0074X032	75B0074X042	75B0074X062	75B0074X052
NOVEX and Phoenix III Seal Ring							
Single Flange	3	75B1047X132	75B1047X072	75B1047X082	---	---	---
	4	75B1048X132	75B1048X072	75B1048X082	---	---	---
	6	75B1049X132	75B1049X072	75B1049X082	---	---	---
	8	75B1542X012	75B1542X022	75B1542X032	---	---	---
	10	75B1543X012	75B1543X022	75B1543X032	---	---	---
	12	75B1544X012	75B1544X022	75B1544X032	---	---	---

Key 8* . Shaft

VALVE SIZE, NPS	MATERIAL				
	17-4PH H1075	S20910	N08020	N10276	N04400
CL150					
2 ⁽¹⁾	75B0609X012	75B0609X022	75B0609X032	75B0609X042	75B0609X052
3	75B0018X012	75B0018X022	75B0018X032	---	75B0018X042
4	75B0040X012	75B0040X022	75B0040X032	75B0040X052	75B0040X042
6	75B0008X012	75B0008X022	75B0008X032	75B0008X052	75B0008X042
8	75B0016X012	75B0016X022	75B0016X032	75B0016X052	75B0016X042
10	75B0026X012	75B0026X022	75B0026X032	75B0026X052	75B0026X042
12	75B0033X012	75B0033X022	75B0033X032	75B0033X052	75B0033X042
CL300					
3	75B0023X012	75B0023X022	75B0023X032	75B0023X052	75B0023X042
4	75B0045X012	75B0045X022	75B0045X032	75B0045X052	75B0045X042
6	75B0006X012	75B0006X022	75B0006X032	75B0006X052	75B0006X042
8	75B0014X012	75B0014X022	75B0014X032	75B0014X052	75B0014X042
10	75B0031X012	75B0031X022	75B0031X032	75B0031X052	75B0031X042
12	75B0038X012	75B0038X022	75B0038X032	75B0038X052	75B0038X042

1. The NPS 2 valve is multi-rated to CL150, 300 and 600.

Key 9* . Hollow Pin (2 req'd)

VALVE SIZE, NPS	CL150				CL300			
	Shaft Material				Shaft Material			
	17-4PH H1075 & S20910	N08020	N10276	N04400	17-4PH H1075 & S20910	N08020	N10276	N04400
3	75B1122X012	75B1122X082	---	75B1122X152	75B1122X022	75B1122X092	75B1122X232	75B1122X162
4	75B1122X022	75B1122X092	75B1122X232	75B1122X162	75B1122X032	75B1122X102	75B1122X242	75B1122X172
6	75B1122X032	75B1122X102	75B1122X242	75B1122X172	75B1122X042	75B1122X112	75B1122X252	75B1122X182
8	75B1122X042	75B1122X112	75B1122X252	75B1122X182	75B1122X052	75B1122X122	75B1122X262	75B1122X192
10	75B1122X052	75B1122X122	75B1122X262	75B1122X192	75B1122X062	75B1122X132	75B1122X272	75B1122X202
12	75B1122X062	75B1122X132	75B1122X272	75B1122X202	75B1122X072	75B1122X142	75B1122X282	75B1122X212

Key 10* . Taper Pin (2 req'd)

VALVE SIZE, NPS	CL150				CL300			
	Shaft Material				Shaft Material			
	17-4PH H1075 & S20910	N08020	N10276	N04400	17-4PH H1075 & S20910	N08020	N10276	N04400
2	12A9019X072	12A9019X052	12A9019X042	12A9019X032	12A9019X072	12A9019X052	12A9019X042	12A9019X032
3	19A3749X012	19A3749X042	---	19A3749X032	F14119X0052	F14119X0062	F14119X0072	F14119X0082
4	F14119X0052	F14119X0062	F14119X0072	F14119X0082	G11299X0032	G1129940092	G1129940152	G1129940022
6	G11299X0032	G1129940092	G11299400152	G1129940022	F13668X0022	F1366840092	F13668X0032	F1366840022
8	F13668X0022	F1366840092	F13668X0032	F1366840022	G13725X0022	G1372540092	G13725X0082	G1372540022
10	G13725X0022	G1372540092	G13725X0082	G1372540022	75B0333X012	75B0333X022	75B0333X032	75B0333X042
12	75B0333X012	75B0333X022	75B0333X032	75B0333X042	75B0334X012	75B0334X022	75B0334X032	75B0334X042

Key 15* . Backup Ring (Use w/ Phoenix III Seal)

VALVE SIZE, NPS	MATERIAL				
	EPR	FKM (Fluorocarbon)	CR (Chloroprene)	Filled Silicone	NBR
3	75B1123X022	75B1123X092	75B1123X162	75B1123X502	75B1123X442
4	75B1123X032	75B1123X102	75B1123X172	75B1123X512	75B1123X452
6	75B1123X042	75B1123X112	75B1123X182	75B1123X522	75B1123X462
8	V110611X032	V110611X022	V110611X042	V110611X072	V110611X062
10	75B0344X012	75B0344X022	75B0344X032	75B0344X062	75B0344X052
12	75B0340X012	75B0340X022	75B0340X032	75B0340X062	75B0340X052

*Recommended spare parts

Figure 14. Valve Assembly for NPS 3 through 12

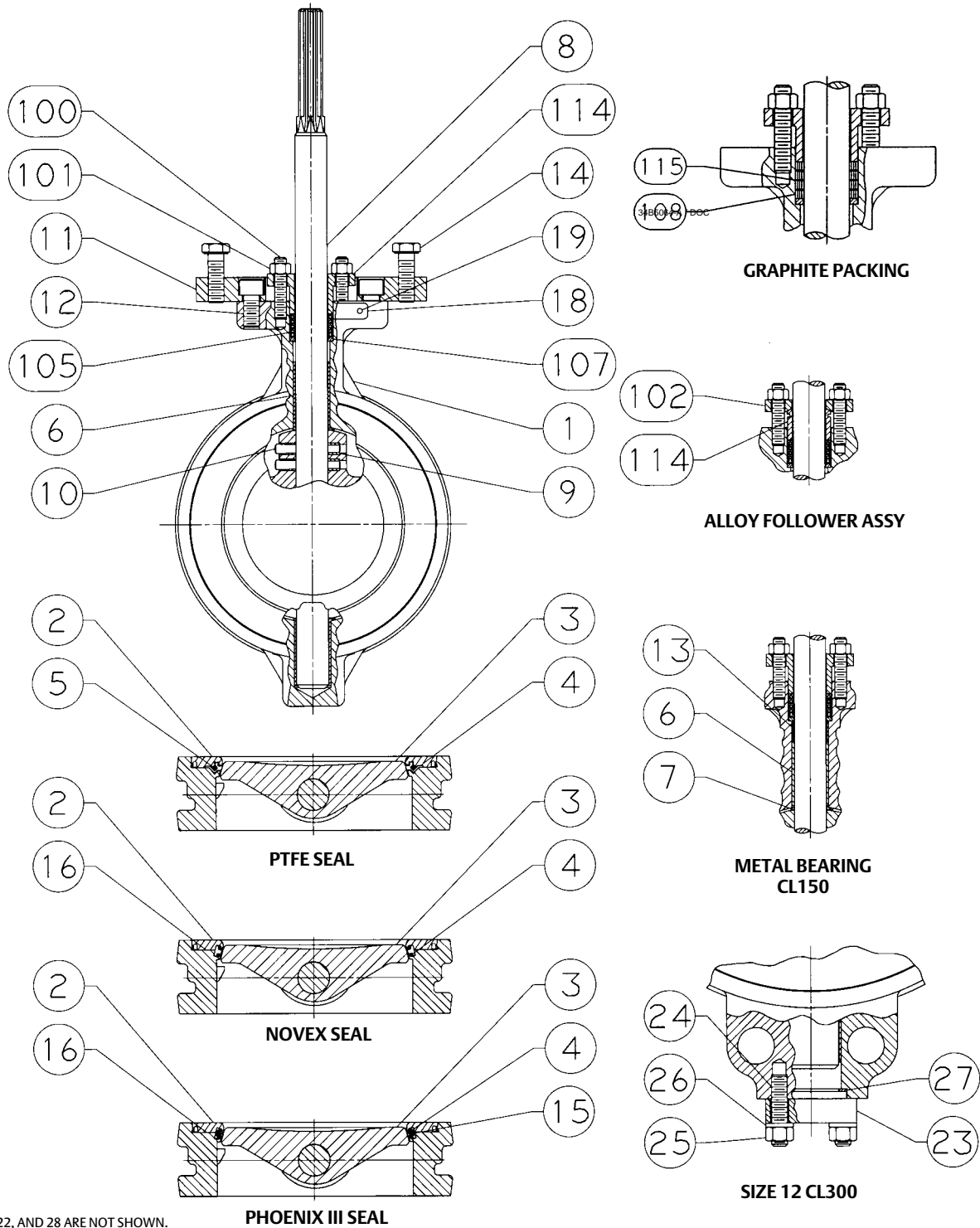

NOTE:
KEYS 21, 22, AND 28 ARE NOT SHOWN.
7580090-A

Figure 14. Valve Assembly for NPS 3 through 12 (Continued)

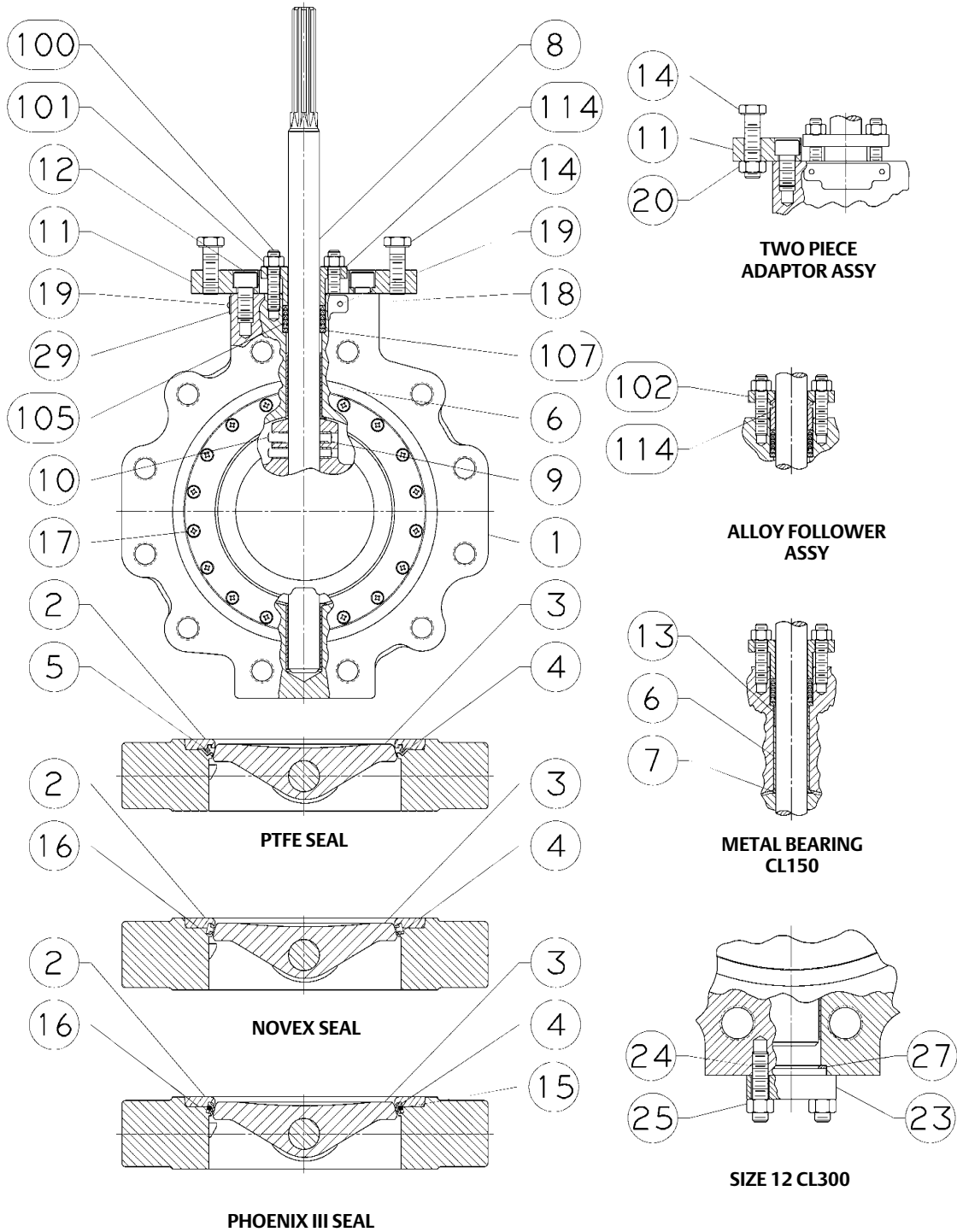

NOTE:
KEY NUMBERS NOT SHOWN ARE 21, 22, AND 115
7580092-B

SINGLE FLANGE-STYLE VALVE

Figure 15. Valve Assembly for NPS 2

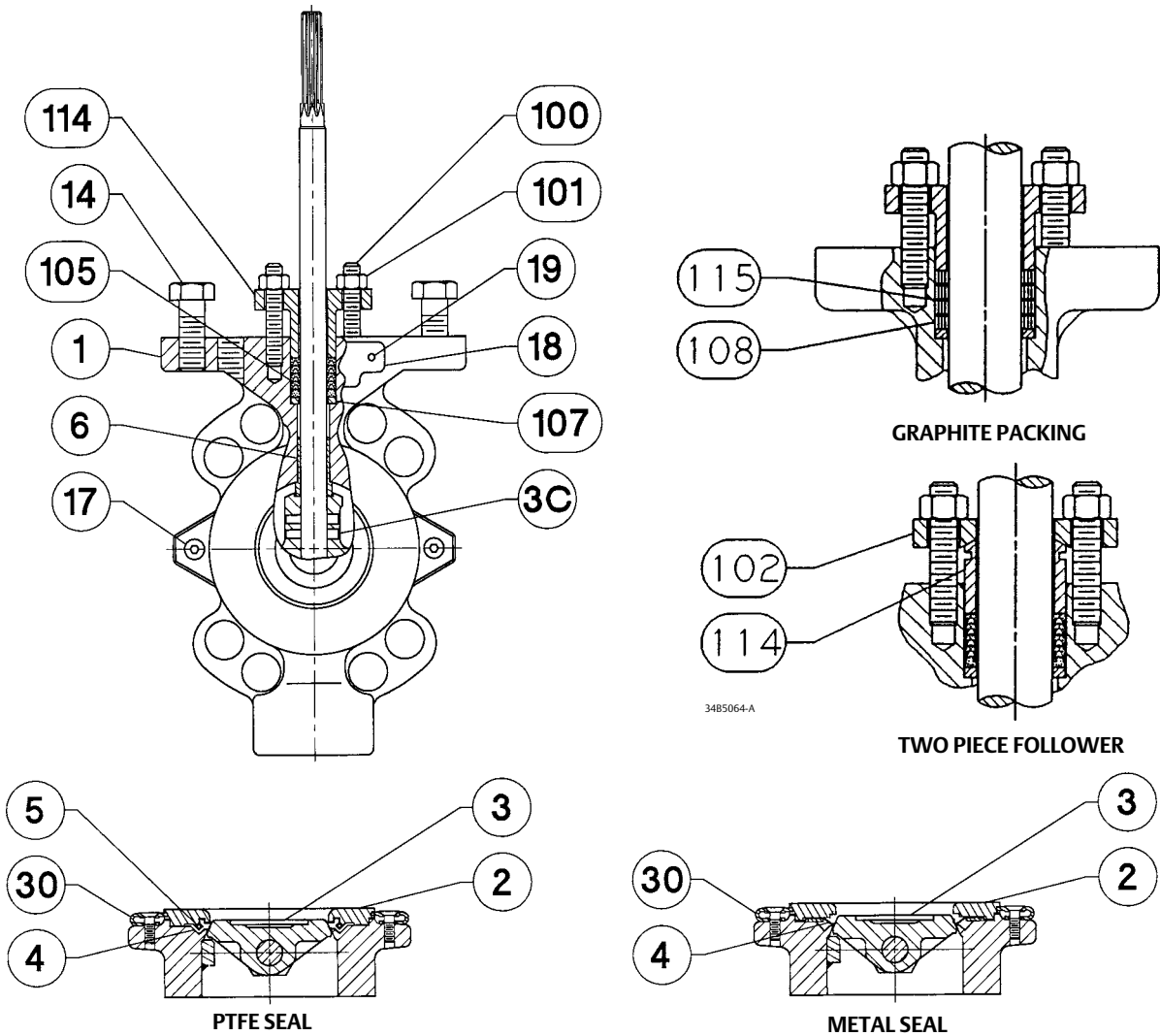

NOTE: PARTS 21 AND 22 NOT SHOWN
7580625

Fisher and ENVIRO-SEAL are marks owned by one of the companies in the Emerson Automation Solutions business division of Emerson Electric Co. Emerson Automation Solutions, Emerson, and the Emerson logo are trademarks and service marks of Emerson Electric Co. All other marks are the property of their respective owners.

The contents of this publication are presented for informational purposes only, and while every effort has been made to ensure their accuracy, they are not to be construed as warranties or guarantees, express or implied, regarding the products or services described herein or their use or applicability. All sales are governed by our terms and conditions, which are available upon request. We reserve the right to modify or improve the designs or specifications of such products at any time without notice. Neither Emerson, Emerson Automation Solutions, nor any of their affiliated entities assumes responsibility for the selection, use or maintenance of any product. Responsibility for proper selection, use, and maintenance of any product remains solely with the purchaser and end user.

Emerson Automation Solutions
Marshalltown, Iowa 50158 USA
Sorocaba, 18087 Brazil
Cernay 68700 France
Dubai, United Arab Emirates
Singapore 128461 Singapore

www.Fisher.com

