

670 Series Panel-Mounted Loading Regulators



P1127_670

**1-GAUGE PANEL
(671 AND 670 SERIES)**



P1128_670G-3

**2-GAUGE PANEL
(670 SERIES)**



P1130_670GV

**2-GAUGE PANEL WITH
CHANGEOVER VALVE
(670 SERIES)**

Figure 1. Typical Panel Layouts

Introduction

The Types 670, 671, 674 and 675 panel-mounted loading regulators (Figures 1, 2, 3 and 6) are compact, rugged units used primarily for manually loading pressure-balanced gas regulators and providing manual control for diaphragm actuator control valves. Applications include remote control of gas pressure to burners in refineries, power plants and various process furnaces. The Types 670 and 675 units use the Type 67CR or 67CFR pressure regulator, the Type 671 unit uses the Type 912 pressure regulator and the Type 674 unit uses the Type 1301F pressure regulator.

Three basic panels are available within the product line as shown in Figures 1 and 6, each having one pressure regulator connected to one or two gauges

or two gauges and a changeover valve. A single gauge typically shows loading pressure to the control valve. With two gauges, one gauge shows the loading pressure and the other gauge can be connected to show downstream control pressure or any other pressure up to 300 psig / 20.7 bar. Manual backup of pneumatic controllers can be handled with those 670 Series units having a changeover valve. With it the operator selects either the automatic controller output (displayed on one gauge) or the manual loader output (displayed on the other gauge and adjusted by the handwheel) as the signal to the control valve actuator.



www.fisherregulators.com



Bulletin 62.3:670

Specifications

This section lists the specifications for the 670 Series panel-mounted loading regulators. Factory specifications are stamped on the nameplate fastened on the regulator at the factory.

Available Configurations

See Table 1

End Connections

Inlet: 1/4 NPT internal

Outlet: Types 670 and 675—1/4 NPT internal;
Type 671—3/8 NPT internal;
Type 674—1/4 NPT internal

Maximum Allowable Inlet Pressure

Without Changeover Valve: 250 psig / 17.2 bar

With Changeover Valve: 50 psig / 3.4 bar

Maximum Outlet Pressure

See Table 1

Maximum Emergency Outlet Pressure

See Table 1

Outlet Pressure Ranges

Types 670 and 675⁽¹⁾: 3 to 18 psig / 0.21 to 1.2 bar
5 to 30 psig / 0.34 to 2.1 bar; 30 to 50 psig / 2.1 to 3.4 bar; and 35 to 100 psig / 2.4 to 6.9 bar except 35 to 50 psig / 2.4 to 3.4 bar with change over valve

Type 671: 0 to 1 psig / 0 to 0.07 bar; 0 to 5 psig / 0 to 0.34 bar

Type 674: 10 to 75 psig / 0.69 to 5.2 bar;
50 to 150 psig / 3.4 to 10.3 bar;
100 to 225 psig / 6.9 to 15.5 bar

Pressure Registration

Internal

Construction Materials

Panel Tubing: Copper, PVC-coated copper, aluminum or 316 (316 Stainless steel)

Regulator Body

Types 670 and 675: Die-cast aluminum

Type 671: Die-cast zinc

Type 674: Brass

Regulator Spring Case

Types 670 and 675: Die-cast zinc/Stainless steel

Type 671: Die-cast zinc

Type 674: Forged brass or steel

Panel

Types 670, 670F and 671: Zinc

Types 670FG, 670G, 670FGV and 670GV: Steel

Handwheel: Die-cast aluminum

Construction Materials (continued)

Other Regulator Parts

Diaphragm: Nitrile (NBR)

Valve Disk: Nitrile (NBR)

Diaphragm Plate: Plated steel

Spring: Plated steel

Filter Cartridge (Type 67CFR Regulator Only):

Cellulose (**standard**) or Stainless steel or Brass

Temperature Capabilities

-20 to 180°F / -29 to 82°C

Pressure Gauges

Connection: 1/8 NPT external fitting on back of case

Ranges: Standard ranges shown in Table 2 with other ranges available upon request

Face Colors: White with black numerals

Case Color: Black

Gauge Identification: White engraving on black laminated plastic plate below gauge indicates units and function. Up to 16 characters per line, 3 lines, are available.

Regulator Port Diameters

Types 670 and 675: 0.125 in. / 3.2 mm

Type 671: 0.073 in. / 1.9 mm (**standard**);

0.094 in. / 2.4 mm (optional)

Type 674: 0.078 in. / 2.0 mm

Operating Influences⁽²⁾

670 Series: As shown in Figure 4, output pressure changes less than 5 psig / 0.34 bar when the input pressure changes between 20 to 140 psig / 1.4 to 9.7 bar

Type 671: As shown in Figure 5, output pressure changes less than 1 in. w.c. / 2 mbar when the input pressure changes between 20 to 140 psig / 1.4 and 9.7 bar

Regulator Flow Capacity

See appropriate pressure regulator bulletin

Internal Relief for Pressure Regulators

Adequate for relieving only minor build-up situations. Refer to the appropriate pressure regulator bulletin to determine if external relief is required.

1. These pressure ranges are recommended, but all springs used in the Type 67CR or 67CFR regulators can be adjusted down to 0 psig / 0 bar.

2. Defined in ISA Standard S51.1-1979.

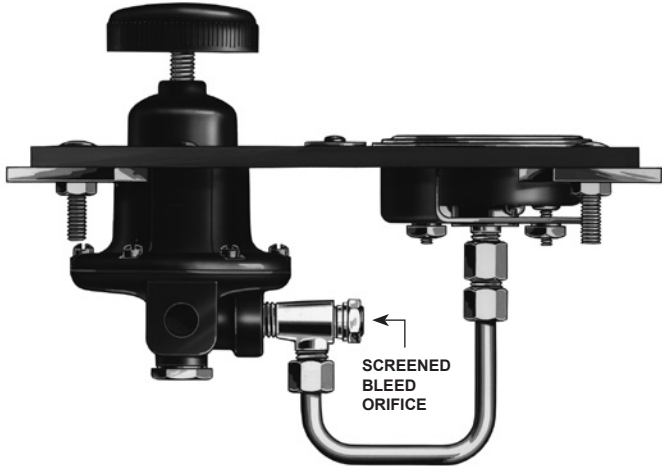

W0532

Figure 2. Type 670 Panel Loader



W6110-1/IL

Figure 3. Side View of Type 671 Panel Loader Using Type 912 Regulator

Features

- **Control Flexibility**—With a changeover valve, the operator can deliver pressure to the control valve from the manual loader, a controller or bypass the panel completely.
- **Gauge Identification**—Big, clear, white-on-black labels (see Figure 1) show gauge function and units at a glance.
- **Convenient Fingertip Control**—Turn the panel-mounted handwheel clockwise to increase or counterclockwise to decrease pressure to the control valve while watching the high visibility black-on-white gauges.
- **Easy Connections**—Unit comes with all the hardware necessary to connect the loading pressure gauge to the pressure regulator.
- **Versatility**—Pressure regulators are suitable for a variety of gaseous fluids including natural gas, propane and air.
- **Compact Size**—The slim profiles of the regulators are ideal for installations where space behind the panel is limited.

Bulletin 62.3:670

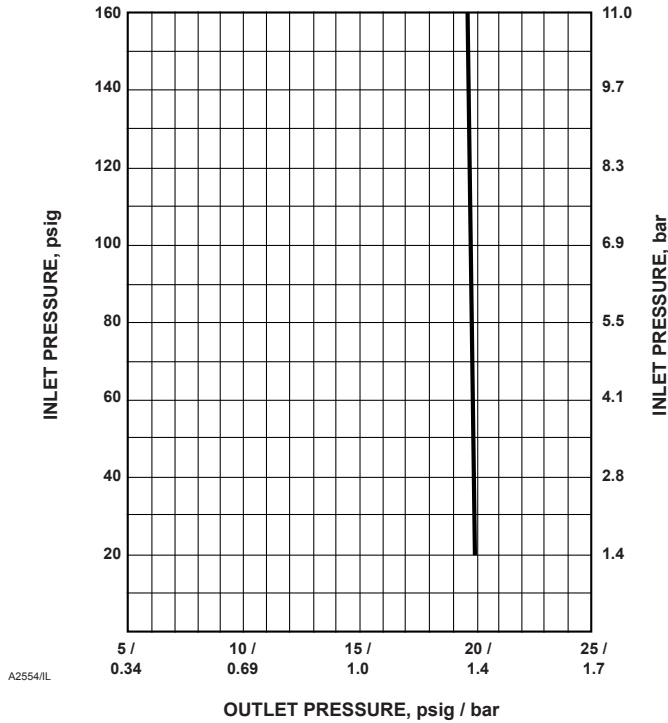

NOTE:
TEST CONDUCTED USING A CONSTANT FLOW RATE OF
50 STANDARD CUBIC FEET PER HOUR AT 60°F AND
14.7 psia (1.3 NORMAL CUBIC METERS PER HOUR AT 0°C
AND 1.01325 bar, ABSOLUTE)

Figure 4. Pressure Variation of Type 67CR Regulator

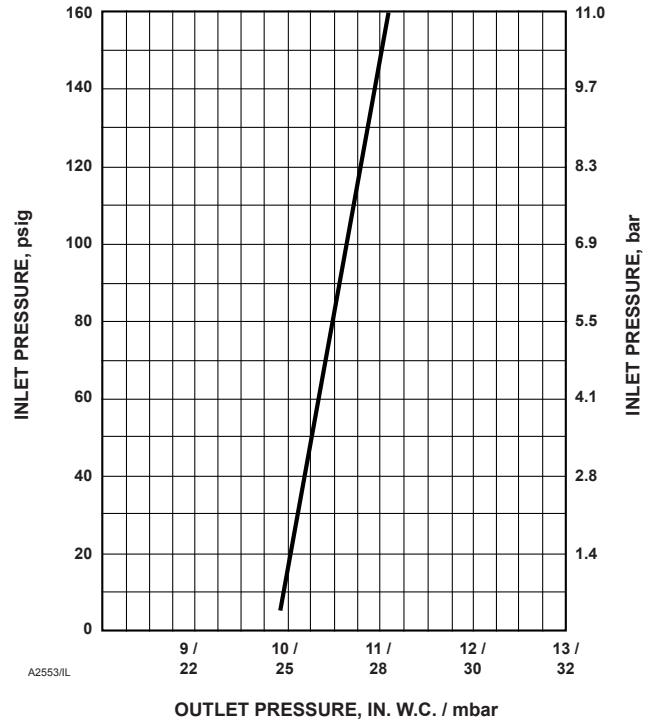

NOTE:
TEST CONDUCTED USING A CONSTANT FLOW RATE OF
50 STANDARD CUBIC FEET PER HOUR AT 60°F AND
14.7 psia (1.3 NORMAL CUBIC METERS PER HOUR AT 0°C
AND 1.01325 bar, ABSOLUTE)

Figure 5. Pressure Variation of Type 912 Regulator

Table 1. Available Configurations

TYPE NUMBER	NUMBER OF GAUGE	DESCRIPTION	REGULATOR TYPE NUMBER	MAXIMUM INLET PRESSURE	MAXIMUM OUTLET PRESSURE	MAXIMUM EMERGENCY OUTLET PRESSURE
670	1	Basic 1-gauge panel	67CR	250 psig / 17.2 bar	100 psig / 6.9 bar	110 psig / 7.6 bar
670F	1	1-gauge panel; regulator has filter	67CFR			
670FG	2	2-gauge panel; regulator has filter	67CFR			
670FGV	2	2-gauge panel with 3-way changeover valve; regulator has filter	67CFR	50 psig / 3.4 bar	50 psig / 3.4 bar	55 psig / 3.8 bar
670G	2	Basic 2-gauge panel	67CR	250 psig / 17.2 bar	100 psig / 6.9 bar	110 psig / 7.6 bar
670GV	2	2-gauge panel with 3-way or 4-way changeover valve	67CR	50 psig / 3.4 bar	50 psig / 3.4 bar	55 psig / 3.8 bar
671	1	Basic 1-gauge panel	912N	250 psig / 17.2 bar	5 psig / 0.34 bar	10 psig / 0.69 bar
674G	2	Basic 2-gauge panel	1301F	6000 psig / 414 bar	225 psig / 15.5 bar	250 psig / 17.2 bar
675G	2	Basic 2-gauge panel	67CR	250 psig / 17.2 bar	100 psig / 6.9 bar	110 psig / 7.6 bar

Table 2. Pressure Gauge Ranges - Triple Scale

psig	Pa	bar
0 to 10	0 to 0.6 K	0 to 0.69
0 to 30	0 to 0.2 M	0 to 2.1
0 to 60	0 to 0.4 M	0 to 4.1
0 to 160	0 to 1.1 M	0 to 11.0
0 to 300	0 to 2 M	0 to 20.7

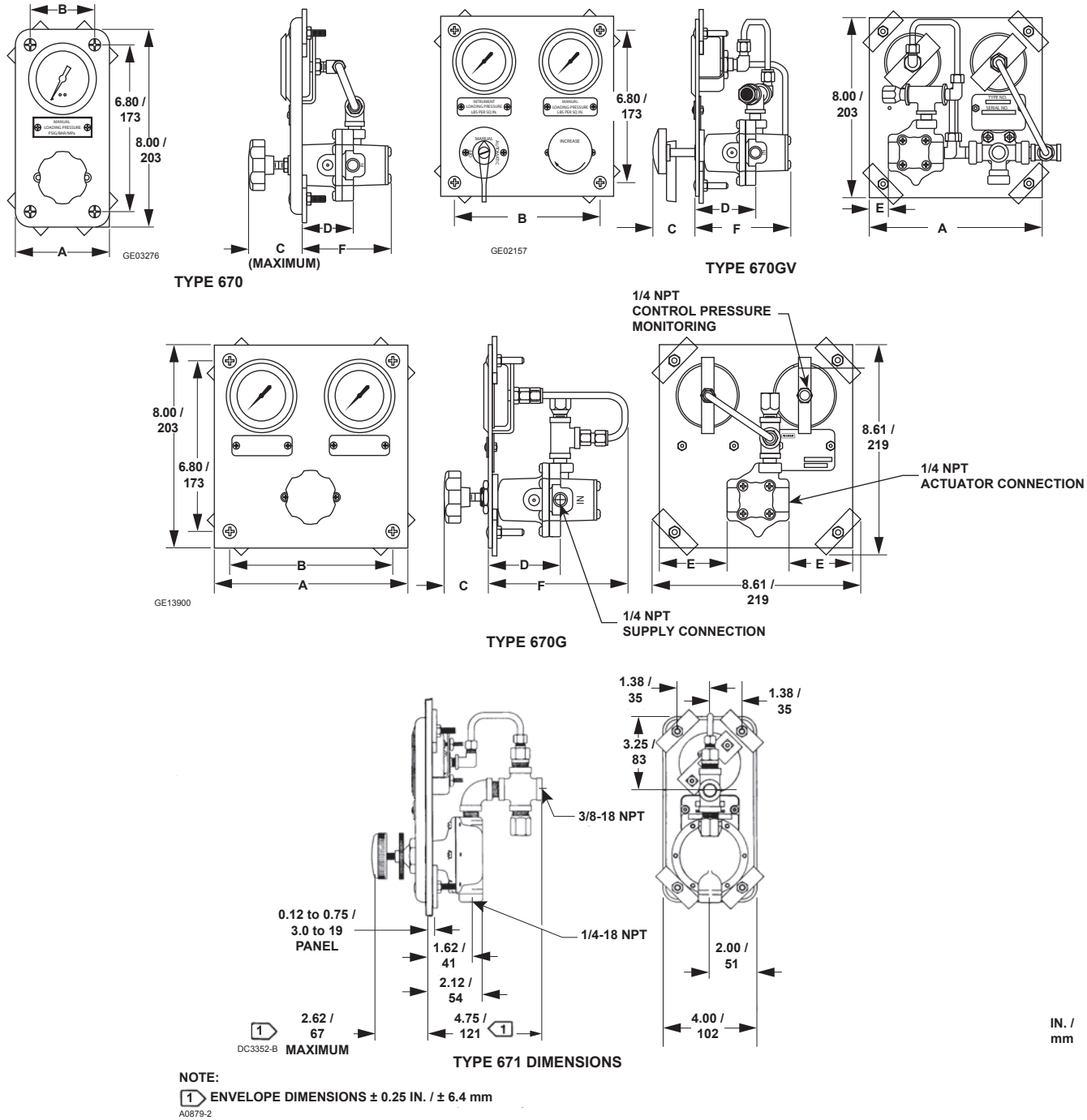

Figure 6. Dimensions

Table 3. Dimension Table

TYPE NUMBER	DIMENSION													
	A		B		C		D		E		F ⁽¹⁾		Panel Count	
	In.	mm	In.	mm	In.	mm	In.	mm	In.	mm	In.	mm	In.	mm
670	4.00	102	2.80	71	2.55	65	2.15	55	0.72	18	3.66	93	3.25 x 7.25	83 x 184
670F	4.00	102	2.80	71	2.70	69	2.00	51	----	----	6.00	152	3.25 x 7.25	83 x 184
670G	8.00	203	6.80	173	2.01	51	2.69	68	2.72	69	5.73	146	7.25 x 7.25	184 x 184
670FG	8.00	203	6.80	173	2.40	61	2.40	61	----	----	7.10	180	7.25 x 7.25	184 x 184
670GV	8.00	203	6.80	173	2.01	51	2.69	68	0.72	18	4.20	107	7.25 x 7.25	184 x 184
670FGV	8.00	203	6.80	173	2.40	61	2.40	61	----	----	7.10	180	7.25 x 7.25	184 x 184
671	4.00	102	2.80	71	2.60	66	2.10	53	----	----	----	----	3.25 x 7.25	83 x 184

1. Dimension F refers to the depth to which those regulators with filters extend behind the panel.

Bulletin 62.3:670

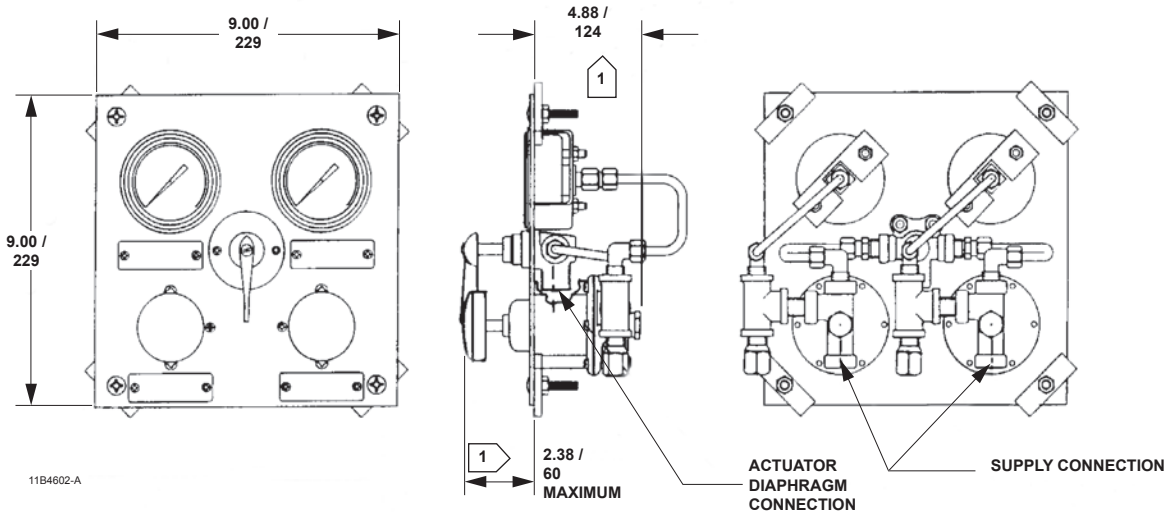

TYPE 675G DIMENSIONS

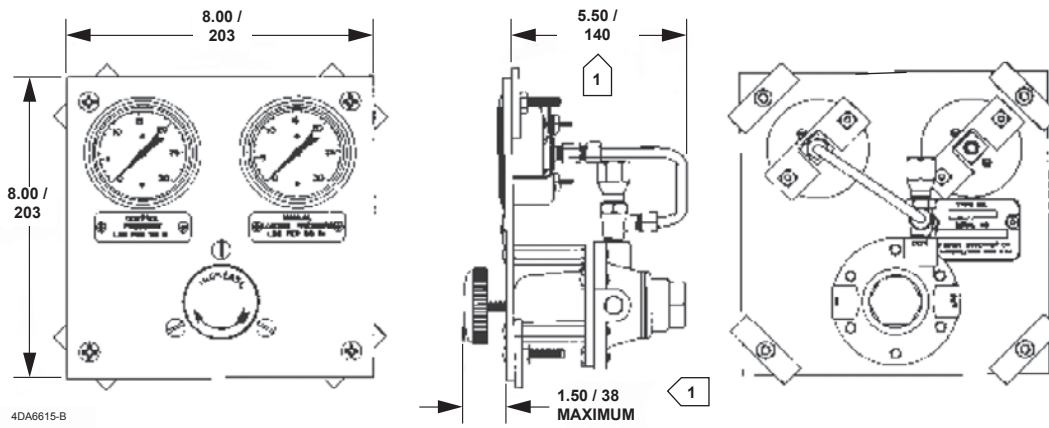

TYPE 674G DIMENSIONS

NOTE:
 ENVELOPE DIMENSIONS ± 0.25 IN. / ± 6.4 mm
 B2405/IL

IN. /
 mm

Figure 6. Dimensions (continued)

Installation

Dimensions for installation clearances are shown in Figure 6.

Ordering Information

When ordering, complete the ordering guide on this page. Refer to the Specifications section on page 2. Review the description to the right of each specification and the information in each referenced table or figure. Specify your choice whenever a selection is offered.

Ordering Guide

Type (See Table 1 for Construction details)

(Select One)

- 670
- 670F
- 670FG
- 670FGV
- 670G
- 670GV
- 671
- 674G
- 675G

- 0 to 10 psig / 0 to 0.6 kPa / 0 to 0.69 bar
- 0 to 30 psig / 0 to 0.2 MPa / 0 to 2.1 bar
- 0 to 60 psig / 0 to 0.4 MPa / 0 to 4.1 bar
- 0 to 160 psig / 0 to 1.1 MPa / 0 to 11.0 bar
- 0 to 300 psig / 0 to 2 MPa / 0 to 20.7 bar

Changeover Valve

- Yes
- No

Outlet Pressure Range (Select One)

Types 670 and 675

- 3 to 18 psig / 0.21 to 1.2 bar
- 5 to 30 psig / 0.34 to 2.1 bar
- 30 to 50 psig / 2.1 to 3.4 bar
- 35 to 100 psig / 2.4 to 6.9 bar except 35 to 50 psig / 2.4 to 3.4 bar with change over valve

Type 671

- 0 to 1 psig / 0 to 0.07 bar
- 0 to 5 psig / 0 to 0.34 bar

Type 674

- 10 to 75 psig / 0.69 to 5.2 bar
- 50 to 150 psig / 3.4 to 10.3 bar
- 100 to 225 psig / 6.9 to 15.5 bar

Pressure Gauge Ranges⁽¹⁾ (Select One)

1. Other ranges available upon request.

Industrial Regulators

Emerson Process Management Regulator Technologies, Inc.

USA - Headquarters
McKinney, Texas 75070 USA
Tel: +1 800 558 5853
Outside U.S. +1 972 548 3574

Asia-Pacific
Shanghai 201206, China
Tel: +86 21 2892 9000

Europe
Bologna 40013, Italy
Tel: +39 051 419 0611

Middle East and Africa
Dubai, United Arab Emirates
Tel: +971 4811 8100

Natural Gas Technologies

Emerson Process Management Regulator Technologies, Inc.

USA - Headquarters
McKinney, Texas 75070 USA
Tel: +1 800 558 5853
Outside U.S. +1 972 548 3574

Asia-Pacific
Singapore 128461, Singapore
Tel: +65 6770 8337

Europe
Bologna 40013, Italy
Tel: +39 051 419 0611
Chartres 28008, France
Tel: +33 2 37 33 47 00

Middle East and Africa
Dubai, United Arab Emirates
Tel: +971 4811 8100

TESCOM

Emerson Process Management Tescom Corporation

USA - Headquarters
Elk River, Minnesota 55330-2445, USA
Tels: +1 763 241 3238
+1 800 447 1250

Europe
Selmsdorf 23923, Germany
Tel: +49 38823 31 287

Asia-Pacific
Shanghai 201206, China
Tel: +86 21 2892 9499

For further information visit www.fisherregulators.com

The Emerson logo is a trademark and service mark of Emerson Electric Co. All other marks are the property of their prospective owners. Fisher is a mark owned by Fisher Controls International LLC, a business of Emerson Process Management.

The contents of this publication are presented for informational purposes only, and while every effort has been made to ensure their accuracy, they are not to be construed as warranties or guarantees, express or implied, regarding the products or services described herein or their use or applicability. We reserve the right to modify or improve the designs or specifications of such products at any time without notice.

Emerson Process Management Regulator Technologies, Inc. does not assume responsibility for the selection, use or maintenance of any product. Responsibility for proper selection, use and maintenance of any Emerson Process Management Regulator Technologies, Inc. product remains solely with the purchaser.