

Fisher™ 656 Diaphragm Actuator

The Fisher 656 actuator is a bracket-mounted, direct-acting, diaphragm actuator for either throttling or on-off service. Principal applications include operation of butterfly valves and built-in turbine valves, louvers, dampers, and other similar equipment.

Features

- **Mounting Versatility**—Four tapped holes in the actuator base permit either bracket or plate mounting.
- **Long Actuator Travel**—Deep casings provide up to 105 mm (4.125 inches) of maximum travel with a size 60 actuator.
- **Application Versatility**—Wide spring selection is available for nearly any control application. Spring selection procedures are quick and accurate.
- **Severe Service Capability**—Rugged yoke and casings provide stability and corrosion resistant protection.

Installation

The actuator may be installed in any position. Dimensions are shown in figure 1.

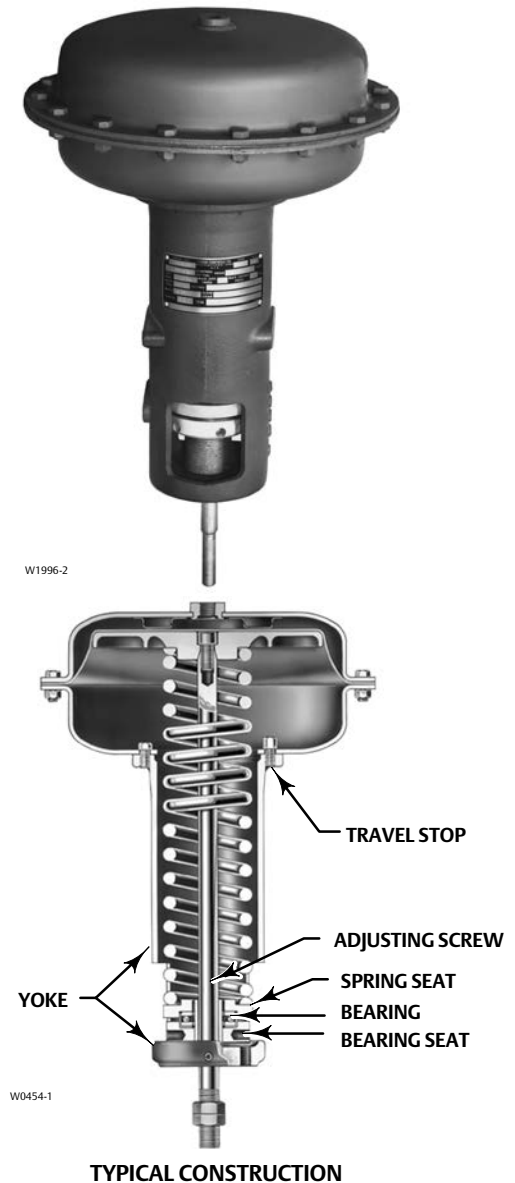

TYPICAL CONSTRUCTION

Fisher 656 Actuator

Specifications

Maximum Recommended Casing Operating Pressure⁽¹⁾

2.4 bar (35 psig)

Maximum Allowable Casing Pressure⁽²⁾⁽⁴⁾

Actuator Size	Maximum Casing Pressure for Actuator Sizing ^(2a) , Bar (Psig)	Maximum Excess Diaphragm Pressure ^(1a) , Bar (Psig)	Maximum Diaphragm Casing Pressure ^(2a,3a) , Bar (Psig)
30	8.6 (125)	1.0 (15)	9.7 (140)
40	4.5 (65)	0.69 (10)	5.2 (75)
60	2.8 (40)	0.69 (10)	3.4 (50)

1a. Additional pressure may be added when the actuator is at full travel. If the Maximum Excess Diaphragm Pressure is exceeded, damage to the diaphragm or diaphragm casing might result. See the Maximum Pressure Limitation section.
 2a. Maximum diaphragm casing pressure must not be exceeded and must not produce a force on the actuator stem greater than the maximum allowable actuator output thrust or the maximum allowable stem load. See the Maximum Pressure Limitation section.
 3a. This maximum casing pressure is not to be used for normal operating pressure. Its purpose is to allow for typical regulator supply settings and/or relief valve tolerances.

Net Stem Force Output

See table 1

Springs Commonly Used with Rotary Valves

See table 2

Maximum Travel

ACTUATOR SIZE	MAXIMUM RATED STEM TRAVEL mm (INCHES)	
	Standard Travel Stop	Optional Travel Stop
30	54 (2.125)	Not available
40	89 (3.5)	76 (3)
60	105 (4.125)	97 (3.8125)

1. Control and stability may be impaired if this pressure is exceeded.
 2. Exceeding this pressure can cause damage to the diaphragm, diaphragm casing, or other parts.
 3. For fluid and temperature capabilities of optional materials, consult your [Emerson sales office](#) or Local Business Partner.
 4. The pressure/temperature limits in this bulletin and any applicable standard or code limitation for valve should not be exceeded

Operating Temperature Range⁽⁴⁾

- -40 to 82°C (-40 to 180°F) with Nitrile Elastomer
- -40 to 149°C (-40 to 300°F) with Silicone Diaphragm

Construction Materials

Part Description	Construction Material
Diaphragm	Nitrile ⁽³⁾ (standard)
Diaphragm plate and yoke	Cast iron
Diaphragm casings, spring, spring seats, travel stop, stem, bearings, bearing seat, and bearing race	Steel
Adjustment screw	Brass

Casing Pressure Connection

1/4 NPT internal

Mounting and Stem Thread Information

See figure 1

Actuator Weight

Actuator Size	Approximate Shipping Weight, kg (Pounds)
30	23 (50)
40	32 (70)
60	73 (160)

Options

Top-mounted handwheel/adjustable travel stop

Ordering Information

When ordering, specify:

1. Actuator type and size
2. Spring range (see table 2)
3. Handwheel or optional travel stop
4. Loading pressure range and volume requirement

Table 1. Stem Force Output and Other Actuator Data

ACTUATOR SIZE	TYPICAL SPRINGS ⁽¹⁾			NET STEM FORCE ⁽²⁾			EFFECTIVE DIAPHRAGM AREA	
	Maximum Range	Part Number	Color Code	Stem Fully Retracted ⁽³⁾	Stem Fully Extended ⁽⁴⁾ , with Diaphragm Loading as Shown	Stem Fully Retracted ⁽³⁾	Stem Fully Extended ⁽⁴⁾	
	Metric Units							
	Bar	---	---	Newtons	Newtons	Bar	cm ²	
30	0.17 to 0.66	1F361627032	Aluminum and orange	734	2322	1.4	425	310
	0.21 to 0.86	1K509827032	Aluminum and dark green	939	1735			
	0.29 to 1.2	1N751527032	Aluminum and red	1321	698			
	0.26 to 1.3	1F177027092	Tan	1143	525			
	0.27 to 1.6	1F177127092	Brown	1232	1699	2.1		
0.21 to 1.8	1F177227092	Pink	939	1108				
40	0.21 to 0.88	1L217427042	White	1468	2424	1.4	645	445
	0.41 to 1.9	1L217327042	Dark green	2802	1201	2.1		
	0.30 to 2.2	1N844027082	None ⁽⁵⁾	2002	1632	2.4		
60	0.26 to 0.90	1K162727082	None ⁽⁵⁾	3541	5360	1.4	1387	1032
	0.24 to 1.1	1N937327082	None ⁽⁵⁾	3350	3336			
	0.49 to 1.9	1K162827082	None ⁽⁵⁾	6503	3034	2.1		
	0.48 to 2.3	1P270227042	None ⁽⁵⁾	6410	2224			
	US Units							
	Psig	---	---	Pounds	Pounds	Psig	Square Inches	
30	2.5 to 9.6	1F361627032	Aluminum and orange	165	522	20 psig	66	48
	3.0 to 12.5	1K509827032	Aluminum and dark green	211	390			
	4.3 to 17.6	1N751527032	Aluminum and red	297	157			
	3.7 to 18.4	1F177027092	Tan	257	118			
	3.9 to 23.9	1F177127092	Brown	277	382	30 psig		
3.1 to 26.1	1F177227092	Pink	211	249				
40	3.1 to 12.7	1L217427042	White	330	545	20 psig	100	69
	6.0 to 27.4	1L217327042	Dark green	630	270	30 psig		
	4.3 to 31.2	1N844027082	None ⁽⁵⁾	450	367	35 psig		
60	3.7 to 13.1	1K162727082	None ⁽⁵⁾	796	1205	20 psig	215	160
	3.5 to 16.1	1N937327082	None ⁽⁵⁾	753	750			
	7.1 to 27.0	1K162827082	None ⁽⁵⁾	1462	682	30 psig		
	6.9 to 33.5	1P270227042	None ⁽⁵⁾	1441	500			

1. Others available; consult with your [Emerson sales office](#) or Local Business Partner for spring characteristics.
2. For maximum rated stem travel with standard travel stop and zero handwheel limitation.
3. Stem force equals initial spring compression with zero loading pressure.
4. Stem force equals: (loading pressure X diaphragm area with stem fully extended) minus force of springs at maximum compression. Higher pressures can be used, but they must not exceed maximum allowable casing pressure or create stem force greater than safe load limit of any control device component.
5. Part number stamped on spring.

Table 2. Springs Commonly Used with Rotary Valves

INPUT SIGNAL	WITH POSITIONER	1.4 BAR (20 PSIG)			2.4 BAR (35 PSIG)		
	WITHOUT POSITIONER	0.2 to 1.0 BAR (3 to 15 PSIG)			0.4 to 2.1 BAR (6 to 30 PSIG)		
ACTUATOR SIZE		30	40	60	30	40	60
MAXIMUM RATED TRAVEL⁽¹⁾, mm (INCHES)		54 (2.125)	89 (3.5)	105 (4.125)	54 (2.125)	89 (3.5)	105 (4.125)
SPRING PART NUMBER⁽²⁾		1K509827032	1K217427042	1K162727082	1F177227092	1L217327042	1K162827082

1. With standard travel stop and zero handwheel limitation.
2. For torque outputs using common springs, contact your Emerson sales office or Local Business Partner.

Table 3. Dimensions

ACTUATOR SIZE	DIMENSION									
	A	C	E		H	J	S (Stem Thread)	X	Y (4 Holes)	
			Without Handwheel	With Handwheel					Bolt Circle Diameter	Thread
mm										
30	67	289	314	490	54	171	1/2-20	19	73	3/8-16 UNC
40	79	333	454	723	64	222	3/4-16	19	73	3/8-16 UNC
60	79	473	692	1014	64	222	3/4-16	32	99	1/2-13 UNC
Inches										
30	2.62	11.38	12.38	19.32	2.12	6.75	See above	0.75	2.88	See above
40	3.12	13.12	17.88	28.38	2.50	8.75		0.75	2.88	
60	3.12	18.62	27.25	39.94	2.50	8.75		1.25	3.88	

Figure 1. Dimensions (also see table 3)

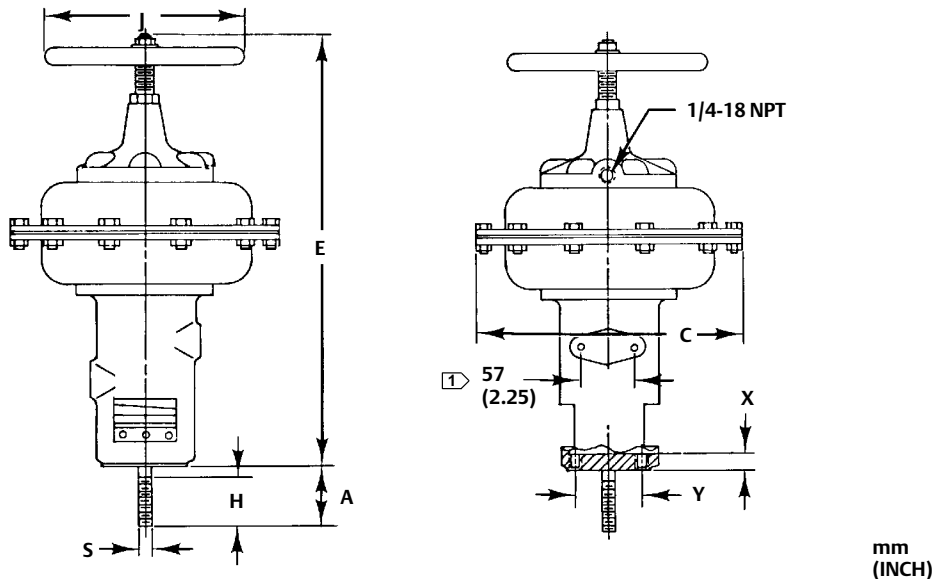

Note:

① Duplicated on opposite side; each hole 5/16-18 UNC-2B tapped 13 (0.50) deep.

Neither Emerson, Emerson Automation Solutions, nor any of their affiliated entities assumes responsibility for the selection, use or maintenance of any product. Responsibility for proper selection, use, and maintenance of any product remains solely with the purchaser and end user.

Fisher is a mark owned by one of the companies in the Emerson Automation Solutions business unit of Emerson Electric Co. Emerson Automation Solutions, Emerson, and the Emerson logo are trademarks and service marks of Emerson Electric Co. All other marks are the property of their respective owners.

The contents of this publication are presented for informational purposes only, and while every effort has been made to ensure their accuracy, they are not to be construed as warranties or guarantees, express or implied, regarding the products or services described herein or their use or applicability. All sales are governed by our terms and conditions, which are available upon request. We reserve the right to modify or improve the designs or specifications of such products at any time without notice.

Emerson Automation Solutions
Marshalltown, Iowa 50158 USA
Sorocaba, 18087 Brazil
Cernay, 68700 France
Dubai, United Arab Emirates
Singapore 128461 Singapore

www.Fisher.com

