

# Fisher™ 4196 Temperature Indicating Controllers

Fisher 4196 temperature indicating controllers show process temperature and set point on an easy-to-read process scale. The controllers are used in industries requiring accurate process monitoring and temperature control.

A temperature bulb (figure 6) measures process temperature. A 4196 controller then compares

process temperature with an operator-adjusted set point. The controller delivers a pneumatic signal to a control element. The control element changes the process temperature toward the set point.

Controller types are available for proportional-only, proportional-plus-reset, proportional-plus-reset-plus-rate, and differential gap for on-off control.



W5823

PIPESTAND-MOUNTED CONTROLLER

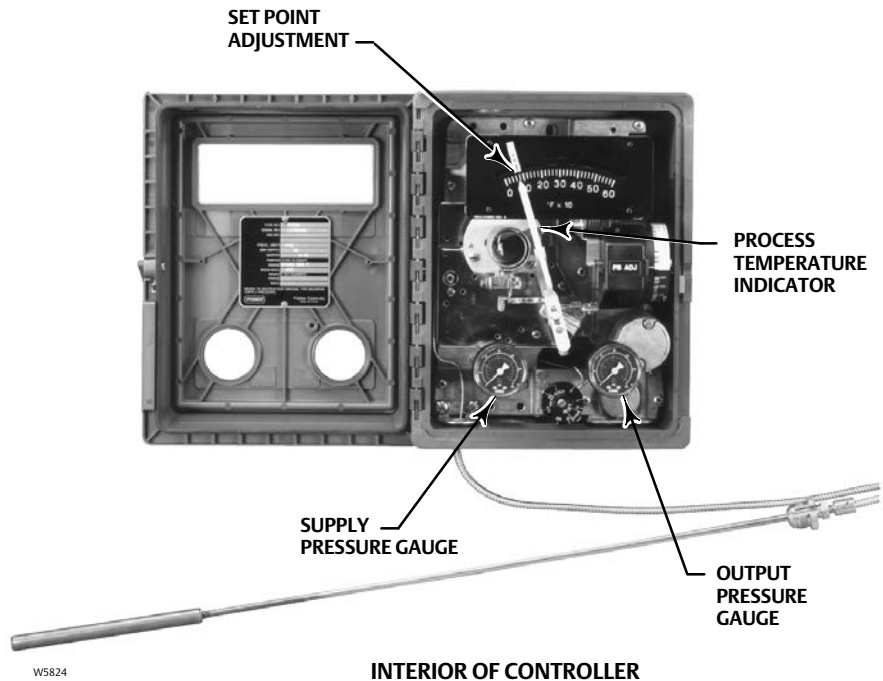

W5824

INTERIOR OF CONTROLLER

**Specifications**

**Available Configurations**

See table 1

**Process Sensor Range (Input Signal)**

Type: Temperature between -73 and 371°C (-100 and 700°F). See table 2 for available ranges  
 Minimum Span: 60°C or 100°F  
 Maximum Span: 300°C or 600°F

**Output Signal**

Proportional or Proportional-Plus-Reset Range:  
 ■ 0.2 to 1.0 bar (3 to 15 psig) or ■ 0.4 to 2.0 bar (6 to 30 psig)

Differential Gap Output: ■ 0 and 1.4 bar (0 and 20 psig) or ■ 0 and 2.4 bar (0 and 35 psig)

**Action:** Field-reversible between ■ direct (increasing sensed temperature increases output pressure) or ■ reverse (increasing sensed temperature decreases output pressure)

**Process Scale**

Matched to the range of the sensing element as standard. Optional<sup>(1)</sup> scales available.

**Supply and Output Connections**

1/4 NPT internal

**Supply Pressure Requirements<sup>(2)</sup>**

See table 3

**Supply Pressure Medium**

Air or non-corrosive Natural Gas

**Remote Set Point Pressures**

■ 0.2 to 1.0 bar (3 to 15 psig) or ■ 0.4 to 2.0 bar (6 to 30 psig)

**Maximum Allowable Pressure in Closed Vessel (For Temperature Element Assembly)<sup>(3)</sup>**

9.7 mm (3/8-Inch) Diameter Temperature Bulb:  
69 bar (1000 psig)

14.3 mm (9/16-Inch) Diameter Temperature Bulb:  
34.5 bar (500 psig)

**Construction Materials**

See table 4

**Controller Adjustments**

Proportional Band: 5 to 500% of process scale range  
 Reset: Adjustable from 0.01 to more than 74 min per repeat (from 100 to less than 0.0135 repeats per min)  
 Differential Gap Controllers: Adjustable from 1 to 100% of process scale range  
 Set Point: Continuously adjustable from 0 to 100% of the scale range

**Controller Performance**

Repeatability: 0.4% of output span  
 Dead Band: Less than 0.4% of process scale range  
 Time Constant of Temperature Bulb: 6 to 12 seconds for a 93°C (200°F) span (bare bulb in agitated liquid)

**Steady-State Air Consumption<sup>(4)(5)</sup>**

0.2 to 1.0 Bar (3 to 15 psig) Output:  
0.08 m<sup>3</sup>/hr (2.8 scfh)  
 0.4 to 2.0 Bar (6 to 30 psig) Output:  
0.07 m<sup>3</sup>/hr (2.5 scfh)

**Operative Ambient Temperature Limits<sup>(2)(6)</sup>**

-40 to 70°C (-40 to 160°F)

-continued-

**Table of Contents**

Features .....	4	Remote Set Point Option .....	9
Construction Features .....	6	Auto/Manual Station Option .....	9
Principle of Operation .....	7	External Feedback Option .....	10
Proportional-Only Controllers .....	7	Installation .....	11
Proportional-Plus-Reset .....	7	Ordering Information .....	14
Proportional-Plus-Reset-Plus Rate Controllers .....	7	Applications .....	14
Differential Gap Controllers .....	7	Construction .....	14
Anti-Reset Windup Option .....	7		

**Specifications (continued)**

**Hazardous Area Classification**

Complies with the requirements of ATEX Group II Category 2 Gas and Dust

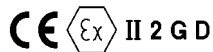

Meets Customs Union technical regulation TP TC 012/2011 for Groups II/III Category 2 equipment

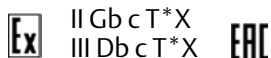

**Housing**

Designed to NEMA 3 (Weatherproof) and IEC 529 IP54 specifications

**Mounting**

Controller can be mounted on ■ actuator, ■ panel, ■ wall, or ■ pipestand

**Approximate Weight**

4.5 kg (10 lb)

Note: Specialized instrument terms are defined in ANSI/ISA Standard 51.1 - Process Instrument Terminology.

1. Consult your [Emerson sales office](#) or Local Business Partner for additional information.

2. The pressure/temperature limits in this document and any applicable standard or code limitation should not be exceeded.

3. At 40°C (100°F)

4. Normal m<sup>3</sup>/hr--normal cubic meters per hour (m<sup>3</sup>/hr, 0°C and 1.01325 bar, absolute). Scfh--standard cubic feet per hour (ft<sup>3</sup>/hr, at 60°F and 14.7 psig).

5. Without auto/manual switch. With auto/manual switch add 0.01 m<sup>3</sup>/hr (0.5 scfh).

6. Also for transportation and storage limits.

**Table 1. Available Configurations**

TYPE NUMBER <sup>(1)</sup>	CONFIGURATIONS						
	Proportional-Only Suffix Letter A	Proportional-Plus Reset Suffix Letter B	Proportional-Plus Reset-Plus-Rate Suffix Letter C	Differential Gap Suffix Letter S	Anti-Reset Windup Suffix Letter F	Remote Set Point Suffix Letter M	Internal Auto/Manual Station Suffix Letter E
4196A	X	---	---	---	---	---	---
4196AE	X	---	---	---	---	---	X
4196AM	X	---	---	---	---	X	---
4196AME	X	---	---	---	---	X	X
4196B	---	X	---	---	---	---	---
4196BE	---	X	---	---	---	---	X
4196BF	---	X	---	---	X	---	---
4196BFE	---	X	---	---	X	---	X
4196BM	---	X	---	---	---	X	---
4196BME	---	X	---	---	---	X	X
4196BFM	---	X	---	---	X	X	---
4196BFME	---	X	---	---	X	X	X
4196C	---	---	X	---	---	---	---
4196CE	---	---	X	---	---	---	X
4196CF	---	---	X	---	X	---	---
4196CFE	---	---	X	---	X	---	X
4196CM	---	---	X	---	---	X	---
4196CME	---	---	X	---	---	X	X
4196CFM	---	---	X	---	X	X	---
4196CFME	---	---	X	---	X	X	X
4196S	---	---	---	X	---	---	---
4196SE	---	---	---	X	---	---	X
4914HSM	---	---	---	X	---	X	---
4196SME	---	---	---	X	---	X	X

1. Reverse-acting constructions are designated by an R added to the type number.

**Table 2. Available Temperature Ranges of Temperature Bulbs<sup>(1)</sup>**

TEMPERATURE SPAN		ELEMENT RANGE	OPERATING RANGE	TEMPERATURE BULB DIAMETER	OVERRANGE LIMITS <sup>(2)</sup>		MAXIMUM TEMPERATURE <sup>(3)</sup>	
°C Minimum	°C Maximum	°C	°C	mm	°C Minimum	°C Maximum	°C	
Metric Units	100	100	0 to 100	-15 to 150	9.5	-10	150	230
			50 to 150			40	200	
			-15 to 85			-25	135	
	150	150	0 to 150	-30 to 160	14.3	-15	225	190
			60	60		-20 to 40	-30 to 95	
	60	60	0 to 60	-30 to 95	14.3	-6	90	400
			60 to 120	38 to 150		54	150	
	150	150	-75 to 75	-75 to 135	14.3	-90	150	590
			50 to 200	-5 to 200		35	275	
	170	200	0 to 200	-75 to 230	14.3	-20	300	590
275	300	0 to 300	-75 to 370	-30		450		
°F Minimum	°F Maximum	°F	°F	Inch	°F Minimum	°F Maximum	°F	
U. S. Units	175	200	0 to 200	0 to 300	3/8	-20	300	450
			50 to 250			30	350	
			100 to 300			80	400	
	250	300	0 to 300	-25 to 325	9/16	-30	450	375
	100	100	0 to 100	-25 to 200		-10	150	
	100	100	50 to 150	75 to 300	9/16	40	200	750
			100 to 200	75 to 300		65	250	
	125	150	50 to 200	-25 to 225	9/16	35	275	1100
	270	300	100 to 400	25 to 400		70	550	
	300	400	0 to 400	-100 to 450	9/16	-40	600	1100
525	600	0 to 600	-100 to 700	-60		900		

1. Contact your [Emerson sales office](#) or Local Business Partner about other spans and ranges.  
 2. All temperature bulbs are tested to +50 percent of overrange limits. With travel stops in place, if the overrange limits are exceeded, the controller may require recalibration.  
 3. With travel stops in place, temperatures in excess of these values may cause permanent damage to the temperature element.

## Features

- **Easy Maintenance**—Simple design allows fast, easy maintenance and minimal spare parts inventory.
- **Easy Adjustment**—Adjusting the set point, adjusting the zero and span of the process pointer, and switching between direct and reverse action are accomplished quickly and without special tools. Also, no interaction occurs when the set point and proportional band are adjusted.
- **Vibration Resistance**—The simple design and low mass of internal parts allow the controller to withstand the vibrations found in most plant environments.
- **Highly Visible Display**—Two red pointers on a 114 mm (4-1/2 inch), white-on-black scale show process temperature and deviation from set point at a glance. Two other gauges monitor supply and output pressures.
- **Low Air/Gas Consumption**—The relay and nozzle design reduces the steady-state consumption rate to as low as 0.07 m<sup>3</sup>/hr (2.5 scfh); less than the 6 scfh requirement set for the oil and gas industry by the US Environmental Protection Agency (New Source Performance Standards Subpart OOOO, EPA-HQ-QAR-2010-0505).
- **Corrosion Resistance**—Tough plastic housing resists corrosive environments. Internal constructions are available to resist corrosive supply pressure media such as sour gas.

**Table 3. Supply Pressure Data**

Output Signal Range		Normal Operating Supply Pressure <sup>(1)</sup>	Maximum Pressure to Prevent Internal Damage <sup>(2)</sup>
Bar	0.2 to 1.0 or 0 and 1.4 (differential gap)	1.4	2.8
	0.4 to 2.0 or 0 and 2.4 (differential gap)	2.4	2.8
Psig	3 to 15 or 0 and 20 (differential gap)	20	40
	6 to 30 or 0 and 35 (differential gap)	35	40

1. If this pressure is exceeded, control stability may be impaired.  
2. If this pressure is exceeded, damage to the controller may result.

**Table 4. Construction Materials**

Part	Standard Material	Optional Material
Thermal element assembly	N09902 nickel alloy and S30300 (303 stainless steel) <sup>(1)</sup>	---
Case and cover	Polyester plastic	---
Exterior tubing	Copper	■Stainless steel or ■polyethylene
Exterior fittings	C36000 (brass)	■Stainless steel or ■polyethylene
Interior tubing	S30400 (304 stainless steel)	---
Nozzle	S30300	---
Flapper	S31600 (316 stainless steel)	---
Relay springs	■S30200 (302 stainless steel) or ■steel	---
Relay O-rings	Nitrile	---
Relay diaphragms	Nitrile	---
Other relay metal parts	■Aluminum or ■stainless steel	---
Feedback bellows assembly	C51000 (bronze)	S32100 (321 stainless steel)
Supply and output gauges	Brass (wetted parts only)	Stainless steel (wetted parts only)
Bushing	Stainless steel	---
Thermowell	Stainless steel	■Carbon steel or ■N04400 nickel alloy
Remote set point element	■N09902 nickel alloy or ■S30300	---

1. For the temperature bulb, capillary tube, and armor.

Figure 1. Controller Construction Detail

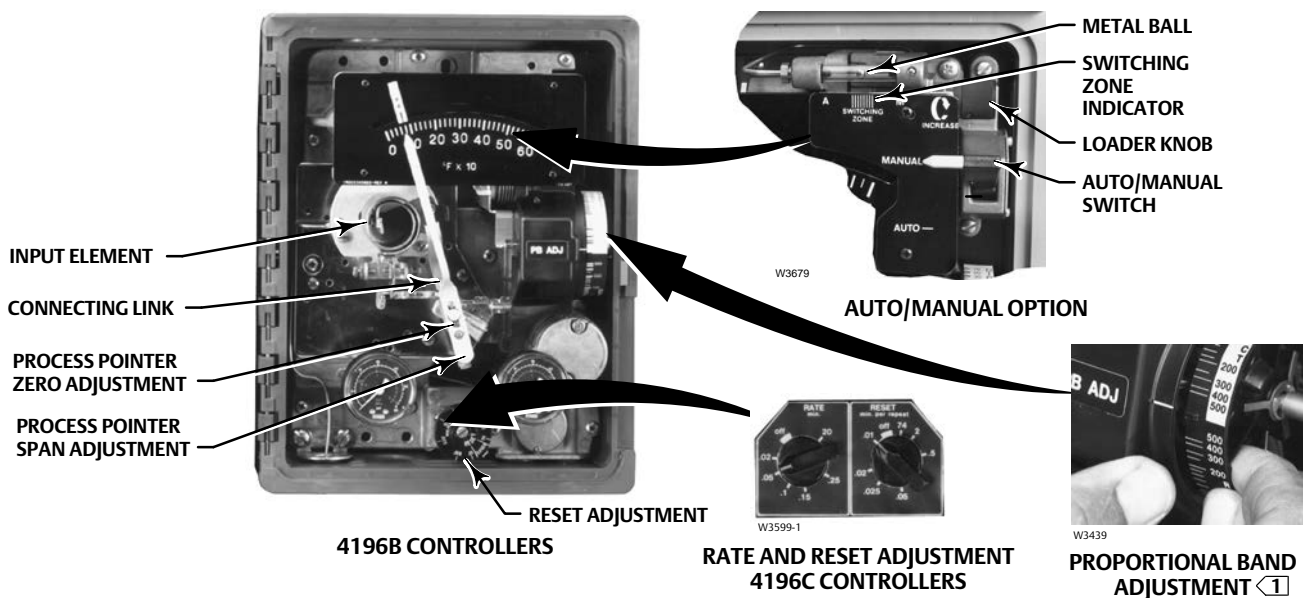

Note:

◻ White portion of proportional band adjustment enables direct controller action; black portion enables reverse controller action.

W5824

## Construction Features

### Simplified Relay Maintenance

A clean-out wire provides a fast, easy means of cleaning the relay primary orifice during service.

### Pressure Protection for the Case

A rubber plug in the plastic case pops out to vent excessive pressure buildup inside the case before structural damage can occur.

### Easy Direct/Reverse Switching

Controller action can be switched from direct to reverse or vice versa by simply loosening the screws on the proportional band cover and moving the cover out to rotate the proportional band knob to the desired action (see figure 1).

### Easy Mode Conversion

Conversion from proportional to proportional-plus-reset control requires the addition of a reset valve and

two pieces of tubing. Conversion from proportional to proportional-plus-reset-plus-rate control requires the addition of a reset/rate valve and three pieces of tubing. Conversion from proportional to differential gap control requires the addition of one piece of tubing. These conversions require removing the controller from the case.

### Anti-Reset Windup

Anti-reset windup is available with proportional-plus-reset and proportional-plus-reset-plus-rate controllers. A relief valve can be adjusted to limit reset windup on either increasing or decreasing output.

### Remote Set Point

The capability of adjusting the set point from a remote location is available as an option with all 4196 controllers.

### Auto/Manual Capability

An optional internal auto/manual station permits smooth, bumpless transfer between automatic control and manual operation without disturbing the controller output. A positive-acting, two-position

switch, showing either automatic or manual control mode, is clearly visible with the controller cover closed.

## External Feedback

In controller override applications, this option minimizes reset windup in the secondary controller. This option is available only with the two-mode (4196B) controllers.

## Principle of Operation

The schematic diagram in figure 2 emphasizes detail of construction variations between control modes. Refer to table 1 to relate type number suffixes to the construction variations.

## Proportional-Only Controllers (4196A)

The input element is connected to the process pointer and to the flapper by connecting links. As the process temperature increases (in a direct-acting controller), the flapper moves toward the nozzle, restricting flow through the nozzle and increasing nozzle pressure. When this occurs, relay action increases the output pressure (delivery) of the controller. Output pressure is fed back to the proportional bellows. The action of the proportional bellows counters the flapper movement that resulted from the process temperature change and backs the flapper away from the nozzle until the controller reaches a point of equilibrium.

The set point adjustment changes the proximity of the nozzle and flapper as does a change in process temperature except that, when the set point is changed, the nozzle moves with respect to the flapper.

The proportional band adjustment knob positions the nozzle on the flapper. Increasing (widening) the proportional band moves the nozzle to a position on the flapper where less flapper motion occurs, decreasing the gain of the controller. Decreasing (narrowing) the proportional band moves the nozzle toward a position where more flapper motion occurs, increasing the gain. Controller action is changed from direct to reverse by turning the proportional band adjustment knob to position the nozzle to a point on the flapper where the direction of the flapper motion versus input motion is reversed (see flapper detail in

figure 2). With the controller in the reverse-acting mode, an increase in process temperature causes a decrease in output pressure.

## Proportional-Plus-Reset Controllers (4196B)

This controller operation is similar to that of proportional-only controllers except that output pressure is fed back to the reset bellows as well as to the proportional bellows. In operation, proportional-plus-reset controllers minimize the offset between the process temperature and set point.

## Proportional-Plus-Reset-Plus-Rate Controllers (4196C)

Figure 3 shows details of the reset/rate option. Controllers with this option have a rate valve, an adjustable restriction that momentarily maintains the controller gain to accelerate the corrective action for slow temperature systems. A proportional-plus-reset-plus-rate controller responds to a change in process temperature as follows:

First, the rate action delays the gain reduction just long enough to allow the system to respond to the change, but not long enough for the system to become unstable. Then, the low gain provided by the proportional action keeps the system stable. Finally, reset action slowly increases the gain and returns the process temperature toward set point.

## Differential Gap Controllers (4196S)





In this version, feedback pressure does not counteract the change in flapper position. Instead, the change is reinforced because feedback pressure is piped directly to the reset bellows only. This construction causes the controller output to switch from full supply pressure to zero pressure or vice versa.

## Anti-Reset Windup Option

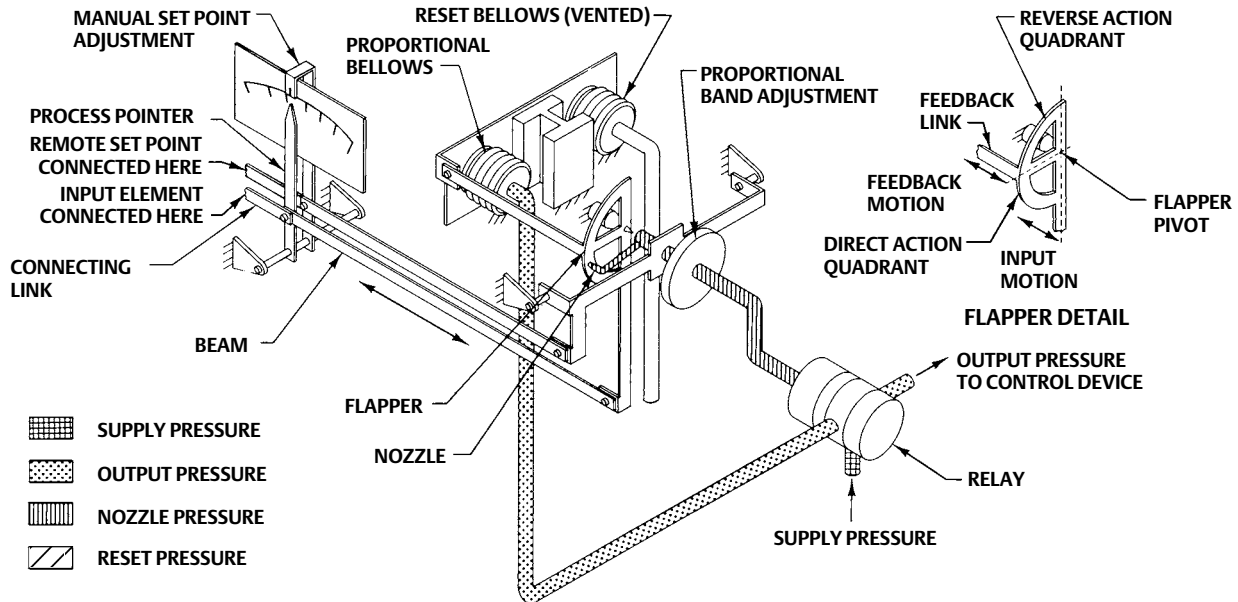
Anti-reset windup is available on all 4196B and 4196C controllers and is designated by the suffix letter F in the type number. The differential relief valve operates when the difference between proportional bellows pressure and reset bellows pressure reaches a predetermined value. Anti-reset windup reduces overshoot of the process temperature that can result from large or prolonged deviation from set point. This option can be adjusted to operate on either increasing or decreasing output pressure.

Figure 2. Schematic of Fisher 4196 Temperature Controllers



-  SUPPLY PRESSURE
-  OUTPUT PRESSURE
-  NOZZLE PRESSURE
-  RESET PRESSURE

PROPORTIONAL-ONLY CONTROL

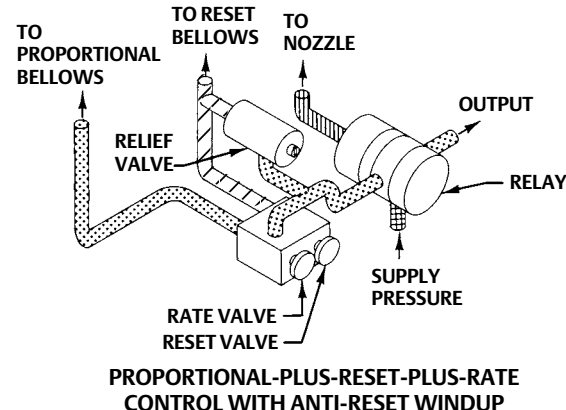
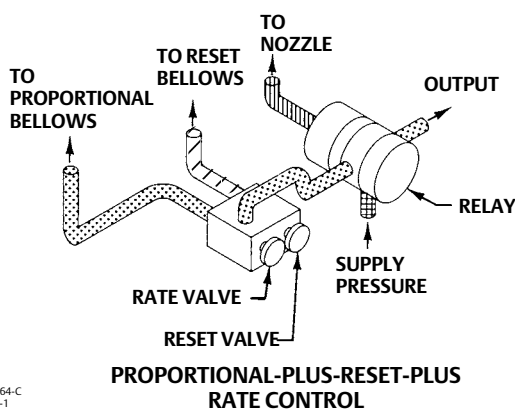
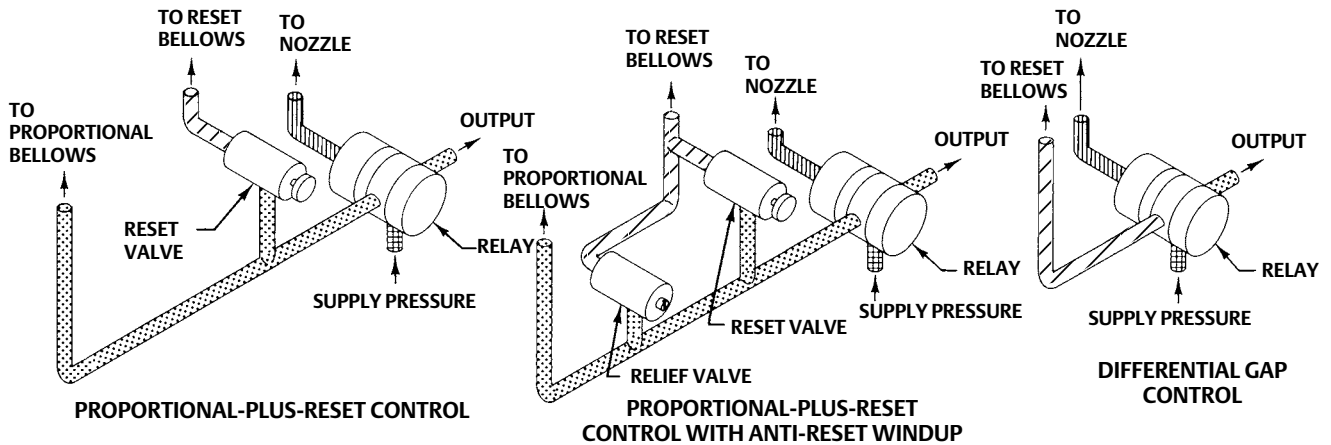

46A9764-C  
C0573-1



Figure 3. Schematic of Reset/Rate Option

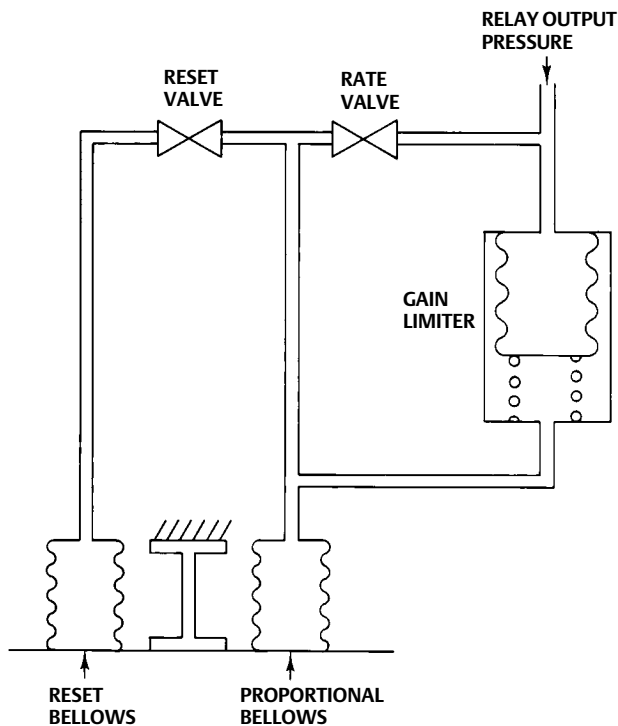

19AS000-A  
A3237-2

## Remote Set Point Option

The optional capability to change the controller set point from a remote location is available with all 4196 controllers. This option is designated by the suffix letter M in the type number.

## Auto/Manual Option

Controllers with the auto/manual option (designated by the suffix letter E in the type number) have piping on the output side of the relay as shown in figure 4. Supply pressure to the relay is also applied to the manual loader. The manual loader, functioning as a regulator, applies pressure to one side of the plastic tube and to the auto/manual switch. Output pressure from the relay registers on the other side of the plastic tube as well as in the auto/manual switch.

When the auto/manual switch is in the MANUAL position, the output of the manual loader becomes the output of the controller. The output of the manual loader is adjustable using the manual loader knob.

When the auto/manual switch is in the AUTO position, the output of the relay is channeled through the switch to become the output of the controller.

Before the auto/manual switch is operated, the output of the relay must equal the output of the manual loader to avoid bumping the process. Adjusting the set point varies the pressure on the left-hand side of the plastic tube. Adjusting the manual loader knob varies the pressure on the right-hand side. When the pressures are equal, the metal ball is centered in the tube. Pressure imbalance will force the ball to one end of the tube where it forms a seal, blocking air flow through the tube.

Figure 4. Schematic of Auto/Manual Option

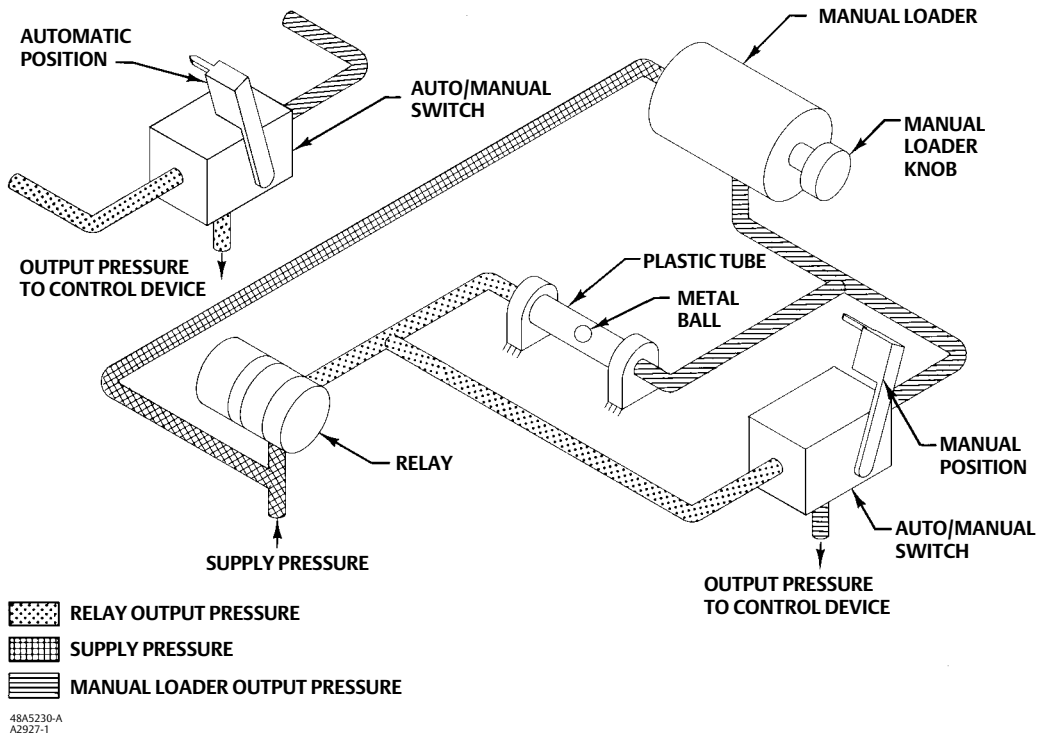

### External Feedback Option

External feedback is available with all 4196B controllers. Controllers with this option have an external process connection on the bottom of the controller case (see figure 8). This connection breaks the positive feedback (reset) loop inside the controller and brings it outside (see figure 5). The connection allows the positive feedback loops of two controllers (primary and secondary) to be tied together when the controllers are used in an override application. Thus connected, the feedback loop of the secondary controller tracks the primary controller, minimizing reset windup.

Figure 5. Schematic of External Feedback Option

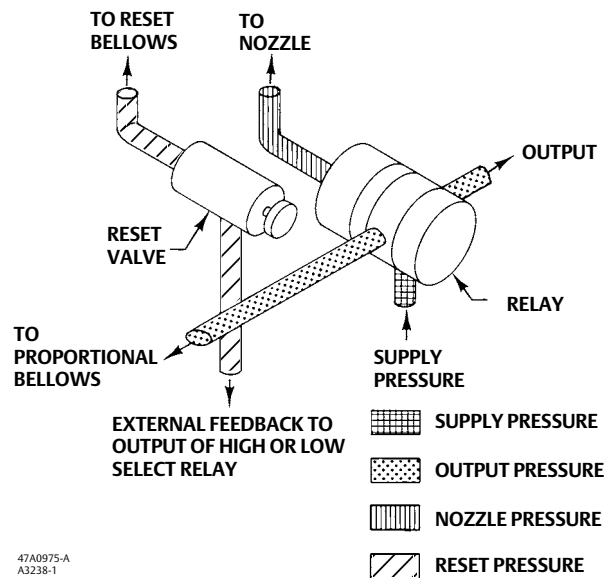

## Installation

In a typical installation, a 4196 temperature controller mounts on a pipestand. The capillary tube length determines the installation site.

When installing a controller, the vent must point down. When the temperature bulb (dimensions shown in table 5 and figure 6) is used within a closed vessel, the bulb screws into a bushing (see figure 7) that penetrates the vessel. Where pressure within the closed vessel exceeds the limits of the temperature

bulb or when the process fluid is corrosive, the temperature bulb screws into a thermowell (see figure 7) that penetrates the vessel. Lag type bushings and thermowells (also shown in figure 7) are used where extra length is required, such as installation in a process vessel that is coated with insulation. Dimensions for bushings and thermowells are shown in figure 7 and tables 6 and 7.

See figure 8 for basic controller dimensions. Figure 9 shows dimensions for specific mounting configurations.

Figure 6. Dimensions for Temperature Bulb with Adjustable Union (also see table 5)

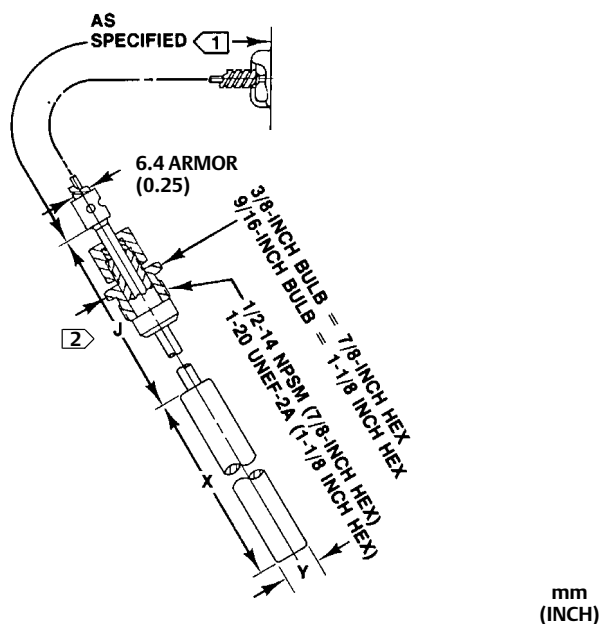

Notes:

- 1 Available in 4.6 and 7.6 m (15 and 25 foot) lengths. Minimum bending radius is 25 mm (1 inch).
- 2 Bendable extension length, Minimum bending radius is 32 mm (1-1/4 inch).
- 3. Temperature bulb may be used with either bushing or thermowell connection parts per SAMA RC6-10.

38A2273-E  
A6921-1

Table 5. Dimensions for Temperature Bulb with Adjustable Union

SAMA STYLE	TEMPERATURE SPANS		DIMENSION						
	°C	°F	B(1)	J		X		Y	
				mm	Inch	mm	Inch	mm	Inch
Adjustable Union (Standard Construction)	100 and 150	200 and 300,	1/2-14 NPSM	445	17.50	145	5.70	10	0.38
	60, 150 through 300	100 and 150, 300 through 600	1-20 UNEF-2A	584	23.00	178	7.00	14	0.56

1. NPSM--National Straight Pipe Threads for Mechanical Joints; UNEF--Unified Thread-Extra

Figure 7. Bushing and Thermowell Dimensions (also see tables 6 and 7)

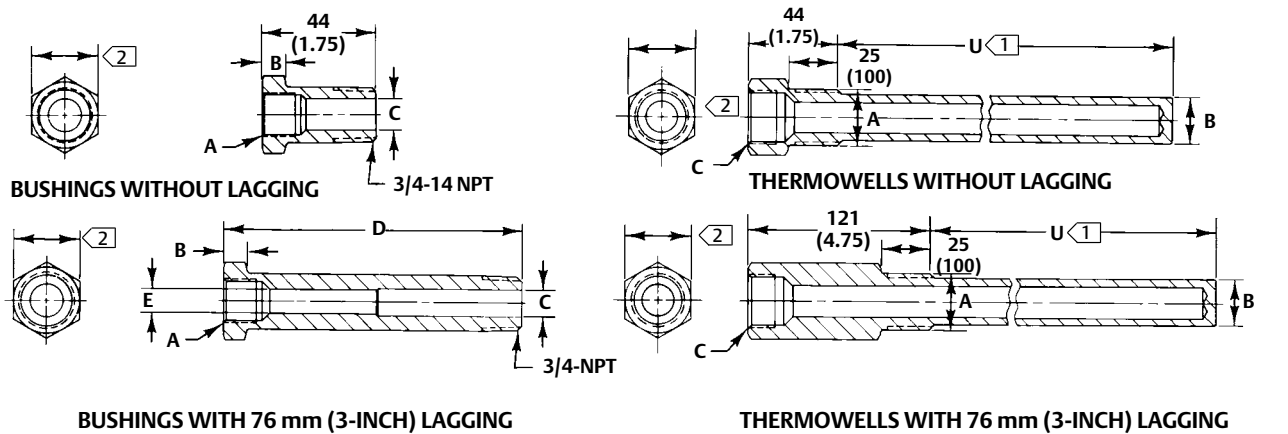

mm  
(INCH)

Notes:

- ① Tolerances for this dimension are as follows:  
± 1.5 mm (0.06 inch) when length is 305 mm (12 inches) or less  
± 3.2 mm (0.125 inch) when length is greater than 305 mm (12 inches)
- ② 7/8-inch hex for 3/8-inch temperature bulb; 1-1/8-inch hex for 9/16-inch temperature bulb

A3240-3

Table 6. Bushing Dimensions

TEMPERATURE BULB DIAMETER		A <sup>(1)</sup>	BUSHINGS WITHOUT LAGGING				BUSHINGS WITH LAGGING							
			B		C		B		C		D		E	
mm	Inch		mm	Inch	mm	Inch	mm	Inch	mm	Inch	mm	Inch	mm	Inch
10	3/8	1/2-14 NPSM	11	0.44	11	0.44	11	0.44	12	0.47	113	4.44	11	0.44
14	9/16	1-20 UNEF	19	0.75	16	0.63	19	0.75	17	0.66	121	4.75	16	0.63

1. Seat area per SAMA Standard RC-17-10.

Table 7. Thermowell Dimensions

TEMPERATURE BULB DIAMETER		A	B		C <sup>(1)</sup>	U (INSERTION LENGTH)	
mm	Inch		mm	Inch		mm	Inch
10	3/8	1/2-14 NPT 3/4-14 NPT	16 20	0.63 0.77	1/2-14 NPSM-2B	191	7.5
						267	10.5
						206	16
14	9/16	3/4-14 NPT	22	0.88	1-20 UNEF-2B	191	7.5
						267	10.5
						406	16
						610	24

1. Seat area per SAMA Standard RC-17-10.

Figure 8. Controller Dimensions

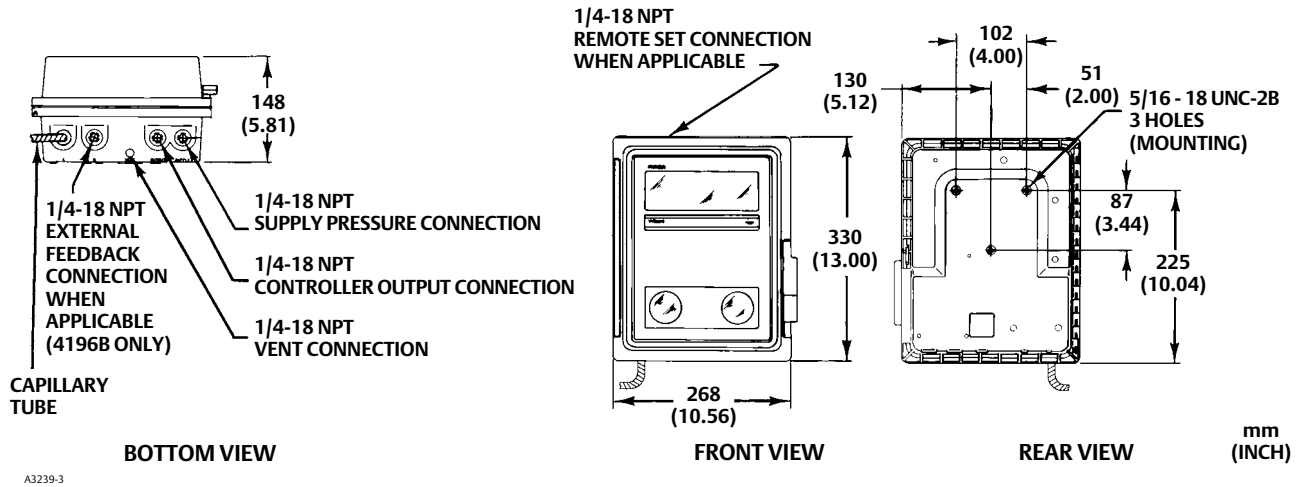
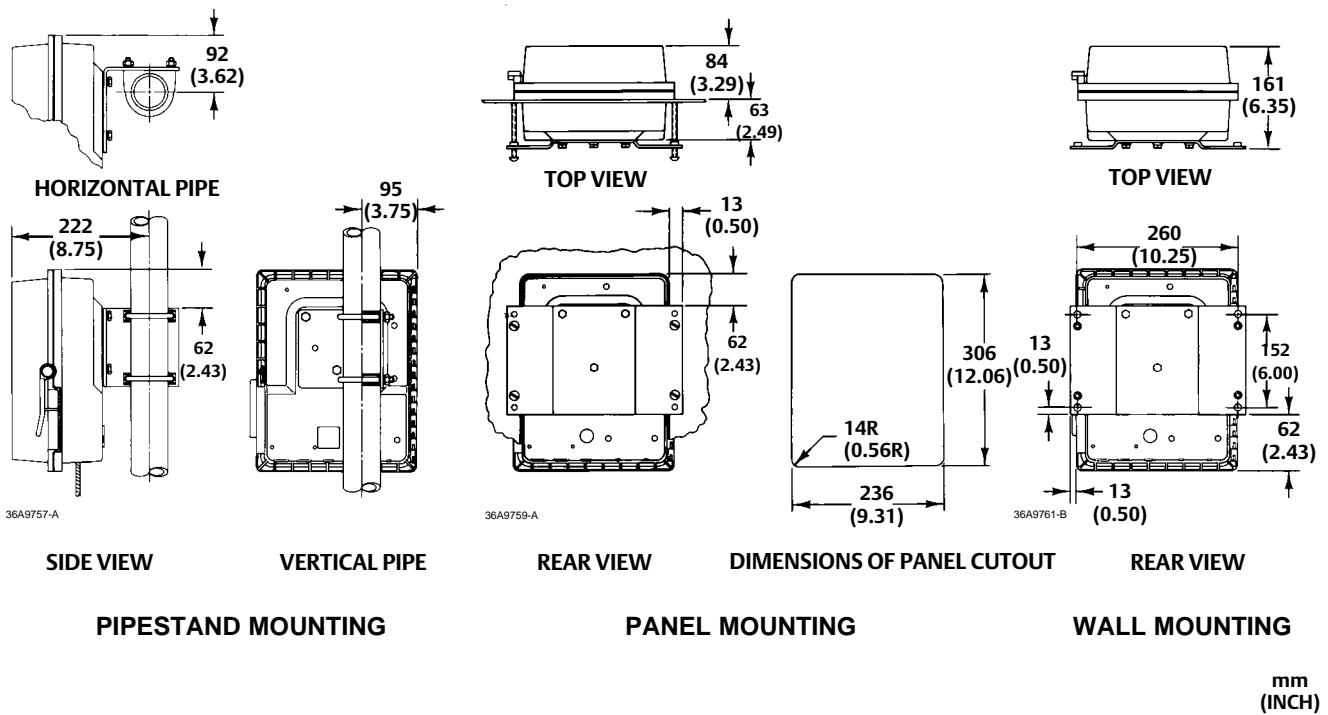

Figure 9. Mounting Dimensions



## Ordering Information

### Applications

When ordering, specify:

1. Description of the service
2. Temperature range of the process
3. Ambient temperature
4. Velocity of the process fluid (if measuring the temperature of a process fluid flowing through a pipe)
5. Pressure in the process vessel (if closed)
6. Bushing or thermowell. Specify either bushing or thermowell (If required) when the temperature bulb

is used in a closed vessel. Refer to figure 7 for available sizes. Specify straight-shank or tapered-shank thermowell. Tapered-shank thermowells, with their high strength-to-weight ratio, permit operation in higher process fluid velocities than do straight-shank thermowells.

### Construction

Refer to the Specifications section and the Construction Features section. Carefully review each specification and feature, specifying your choice whenever a selection is offered. Pipestand mounting hardware will be supplied unless some other mounting method is specified.

Refer to table 1 for type numbers (add R to any type number if reverse action is desired).



## Product Bulletin

34.6:4196  
August 2017

**4196 Temperature Controllers**  
D200054X012

---

Neither Emerson, Emerson Automation Solutions, nor any of their affiliated entities assumes responsibility for the selection, use or maintenance of any product. Responsibility for proper selection, use, and maintenance of any product remains solely with the purchaser and end user.

Fisher is a mark owned by one of the companies in the Emerson Automation Solutions business unit of Emerson Electric Co. Emerson Automation Solutions, Emerson, and the Emerson logo are trademarks and service marks of Emerson Electric Co. All other marks are the property of their respective owners.

The contents of this publication are presented for informational purposes only, and while every effort has been made to ensure their accuracy, they are not to be construed as warranties or guarantees, express or implied, regarding the products or services described herein or their use or applicability. All sales are governed by our terms and conditions, which are available upon request. We reserve the right to modify or improve the designs or specifications of such products at any time without notice.

Emerson Automation Solutions  
Marshalltown, Iowa 50158 USA  
Sorocaba, 18087 Brazil  
Cernay 68700 France  
Dubai, United Arab Emirates  
Singapore 128461 Singapore

[www.Fisher.com](http://www.Fisher.com)

