

Fisher™ 4194 Differential Pressure Indicating Controllers

Fisher 4194 (low pressure) differential pressure indicating controllers show process differential pressure and set point on an easy-to-read process scale. The controllers sense two different pressures and compare the difference between these pressures with an operator-adjusted set point. A pneumatic signal is then delivered to a control element to change the process differential pressure toward the set point. The controllers use a capsular element for differential

pressure up to 2.0 bar (30 psi). They are available for proportional only, proportional-plus-reset, and differential gap control. The controller is also available (see table 1) with anti-reset windup, internal auto/manual station, and remote set point adjustability (see table 1). 4194 controllers are used in industry where process monitoring and accurate measurement of differential pressures are required.



W5850-1

CONTROLLER YOKE-MOUNTED ON ACTUATOR OF CONTROL VALVE

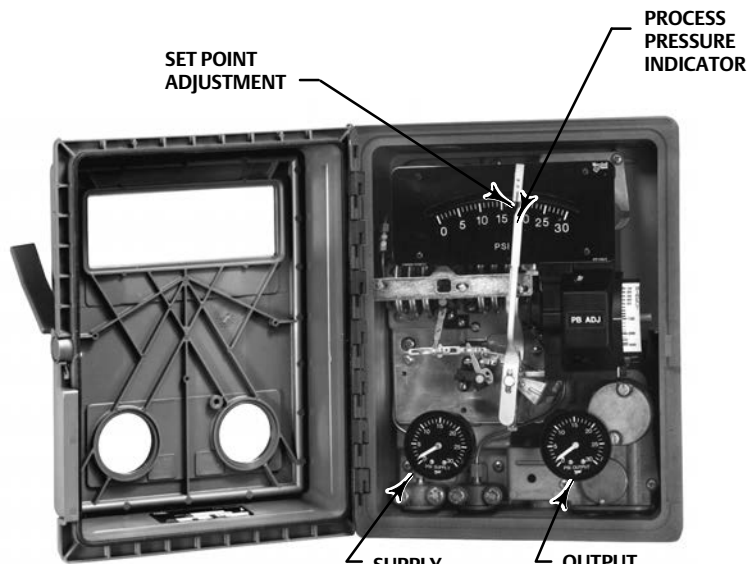

W5827-2

INTERIOR OF CONTROLLER

Specifications

Available Configurations

See table 1

Sensing Element Range (Input Signal)

See table 2

Process Scale

■ Linear, ■ square root, or ■ others on request⁽¹⁾

Process Connections

Standard: 1/4 NPT internal stainless steel (all input ranges)

Optional: 1/2 NPT external stainless steel

Output Signal

Proportional or Proportional-Plus-Reset Range:

■ 0.2 to 1.0 bar (3 to 15 psig) or ■ 0.4 to 2.0 bar (6 to 30 psig)

Differential Gap Output: ■ 0 and 1.4 bar (0 and 20 psig) or ■ 0 and 2.4 bar (0 and 35 psig)

Action: Field-reversible between ■ direct (increasing sensed pressure increases output pressure) or ■ reverse (increasing sensed pressure decreases output pressure)

Supply and Output Connections

1/4 NPT internal

Supply Pressure Requirements⁽²⁾

See table 3

Supply Pressure Medium

Air or non-corrosive Natural Gas

Remote Set Point Pressures

■ 0.2 to 1.0 bar (3 to 15 psig) or ■ 0.4 to 2.0 bar (6 to 30 psig)

Construction Materials

See table 4

Controller Adjustments

Proportional Band: 5 to 500% of process scale range

Reset: Adjustable from 0.01 to more than 74 min per repeat (from 100 to less than 0.0135 repeats per min)

Differential Gap Controllers: Adjustable from 1 to 100% of process scale range

Set Point: Continuously adjustable from 0 to 100% of the scale range.

■ *Internal Set Point Adjustment (standard):* Internal adjustment knob

Controller Performance⁽³⁾

Repeatability: 0.09% of process scale range

Dead Band: Less than 0.2% of process scale range

Typical Frequency Response: 1.5 Hz and 90 deg phase shift with 3.05 m (10 feet) of 6.44 mm (1/4 inch) tubing and 1639 cm³ (100 in.³) volume

Steady-State Air Consumption⁽³⁾⁽⁴⁾

0.2 to 1.0 Bar (3 to 15 psig) Output:

0.08 m³/hr (2.8 scfh)

0.4 to 2.0 Bar (6 to 30 psig) Output:

0.07 m³/hr (2.5 scfh)

Operative Ambient Temperature Limits⁽²⁾⁽⁵⁾

-40 to 70°C (-40 to 160°F)

Hazardous Area Classification

Complies with the requirements of ATEX Group II Category 2 Gas and Dust

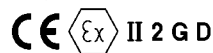

Meets Customs Union technical regulation TP TC 012/2011 for Groups II/III Category 2 equipment

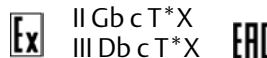

Mounting

Controller can be mounted on ■ actuator, ■ panel, ■ wall, or ■ pipestand

Approximate Weight

4.5 kg (10 lb)

NOTE: Specialized instrument terms are defined in ANSI/ISA Standard 51.1 - Process Instrument Terminology.

1. Consult your [Emerson sales office](#) or Local Business Partner for additional information.

2. The pressure/temperature limits in this document, and any applicable code or standard should not be exceeded.

3. Normal m³/hr--normal cubic meters per hour (m³/hr, 0°C and 1.01325 bar, absolute). Scfh--standard cubic feet per hour (ft³/hr, at 60°F and 14.7 psig).

4. Without auto/manual switch. With auto/manual switch add 0.01 normal m³/hr (0.5 scfh).

5. Also for transportation and storage limits.

Table 1. Available Configurations

TYPE NUMBER ⁽¹⁾	CONFIGURATIONS						
	Proportional-Only	Proportional-Plus Reset	Proportional-Plus Reset-Plus-Rate ⁽²⁾	Differential Gap	Anti-Reset Windup	Remote Set Point	Internal Auto/Manual Station
4194A	X	---	---	---	---	---	---
4194AE	X	---	---	---	---	---	X
4194AM	X	---	---	---	---	X	---
4194AME	X	---	---	---	---	X	X
4194B	---	X	---	---	---	---	---
4194BE	---	X	---	---	---	---	X
4194BF	---	X	---	---	X	---	---
4194BFE	---	X	---	---	X	---	X
4194BM	---	X	---	---	---	X	---
4194BME	---	X	---	---	---	X	X
4194BFM	---	X	---	---	X	X	---
4194BFME	---	X	---	---	X	X	X
4194C	---	---	X	---	---	---	---
4194CE	---	---	X	---	---	---	X
4194CF	---	---	X	---	X	---	---
4194CFE	---	---	X	---	X	---	X
4194CM	---	---	X	---	---	X	---
4194CME	---	---	X	---	---	X	X
4194CFM	---	---	X	---	X	X	---
4194CFME	---	---	X	---	X	X	X
4194S	---	---	---	X	---	---	---
4194SE	---	---	---	X	---	---	X
4914HSM	---	---	---	X	---	X	---
4194SME	---	---	---	X	---	X	X

1. Reverse-acting constructions are designated by an R added to the type number.
2. Consult your [Emerson sales office](#) or Local Business Partner for information on rate.

Features

- **Easy Maintenance**—Simple design of the controller allows fast, easy maintenance and minimal spare parts inventory.
- **Easy Adjustment**—Adjusting the set point and the zero and span of the process pointer and switching between direct and reverse action are accomplished quickly and without special tools. Also, the set point and proportional band can be adjusted with no interaction between the two adjustments.
- **Vibration Resistant**—Simple design and low mass of internal parts allow the controller to withstand vibration encountered in most plant environments.
- **Low Air/Gas Consumption**—The relay and nozzle design reduces the steady-state consumption rate to as low as 0.07 m³/hr (2.5 scfh); less than the 6 scfh requirement set for the oil and gas industry by the US Environmental Protection Agency (New Source Performance Standards Subpart OOOO, EPA-HQ-QAR-2010-0505).
- **Corrosion Resistant**—Tough plastic housing resists corrosive environments. Internal constructions are available to resist a corrosive supply pressure media.
- **Mounting Versatility**—The controller can mount directly on the actuator or it can mount on a pipestand, on a wall, or in a panel.
- **Highly Visible Display**—Two red pointers on a 114 mm (4-1/2 inch) long white-on-black scale show differential pressure and deviation from set point at a glance. Two other gauges monitor supply and output pressures.

Table 2. Process Sensor (Capsular Element) Ranges, and Pressure Ratings

AVAILABLE CAPSULAR ELEMENT RANGES		MINIMUM ⁽¹⁾ DIFFERENTIAL SPAN		MAXIMUM ALLOWABLE ⁽²⁾ DIFFERENTIAL PRESSURE		STATIC PRESSURE OPERATING RANGE				MAXIMUM ALLOWABLE ⁽³⁾ STATIC PRESSURE	
						Minimum		Maximum			
Bar	Psid	Bar	Psid	Bar	Psid	Bar	Inches of Mercury	Bar	Psig	Bar	Psig
0 to 0.4	0 to 5	0.2	2.5	0.4	5	-0.4	-10	0.4	5	0.5	7.5
0 to 0.7	0 to 10	0.4	5.0	0.7	10	-0.7	-20	0.7	10	1.0	15.0
0 to 1.4	0 to 20	0.7	10.0	1.4	20	-1.0	-30	1.4	20	2.1	30.0
0 to 2.0	0 to 30	1.0	15.0	2.0	30	-1.0	-30	2.0	30	3.1	45.0

1. Span is adjustable between minimum shown and maximum of the capsular element operating range and can be positioned anywhere within this range. For example, if a (0 to 2.0 bar (0 to 30 psid) capsular element is used and the minimum span of 1.0 bar (15 psid) is set, the process indication can be calibrated to a range of 0 to 1.0 bar (0 to 15 psid), 1.0 to 2.0 bar (15 to 30 psid), or any value between the minimum and maximum values of the operating range.
 2. Maximum difference between the two input supply pressures.
 3. Capsular element may be pressured to this valve (after reaching travel stop at upper range limit) without permanent zero shift of structural damage to controller components.

Table 3. Supply Pressure Data

Output Signal Range		Normal Operating Supply Pressure ⁽¹⁾	Maximum Pressure to Prevent Internal Damage ⁽²⁾
Bar	0.2 to 1.0 or 0 and 1.4 (differential gap)	1.4	3.4
	0.4 to 2.0 or 0 and 2.4 (differential gap)	2.4	3.4
Psig	3 to 15 or 0 and 20 (differential gap)	20	50
	6 to 30 or 0 and 35 (differential gap)	35	50

1. If this pressure is exceeded, control stability may be impaired.
 2. If this pressure is exceeded, damage to the controller may result.

Table 4. Construction Materials

Part	Standard Material	Optional Material
Case and cover	Polyester plastic	---
Exterior tubing	Copper	Aluminum, stainless steel, steel, or polyethylene
Exterior fittings	C36000 (brass)	Aluminum, stainless steel, steel, or polyethylene
Interior tubing	S30400 (304 stainless steel)	---
Capsular element	N09902 (Nickel alloy)	---
Nozzle	S30300 (303 stainless steel)	---
Flapper	S31600 (316 stainless steel)	---
Relay springs	S30200 (302 stainless steel) or steel	---
Relay O-rings	Nitrile	---
Relay diaphragms	Nitrile	---
Other relay metal parts	Aluminum or stainless steel	---
Feedback bellows assembly	C51000 (bronze)	S32100 (321 stainless steel)
Supply and output gauges	Brass (wetted parts only)	Stainless steel (wetted parts only)
Remote set point bellows	N09902	---

Figure 1. Operational Schematic of Fisher 4194 Differential Pressure Controllers

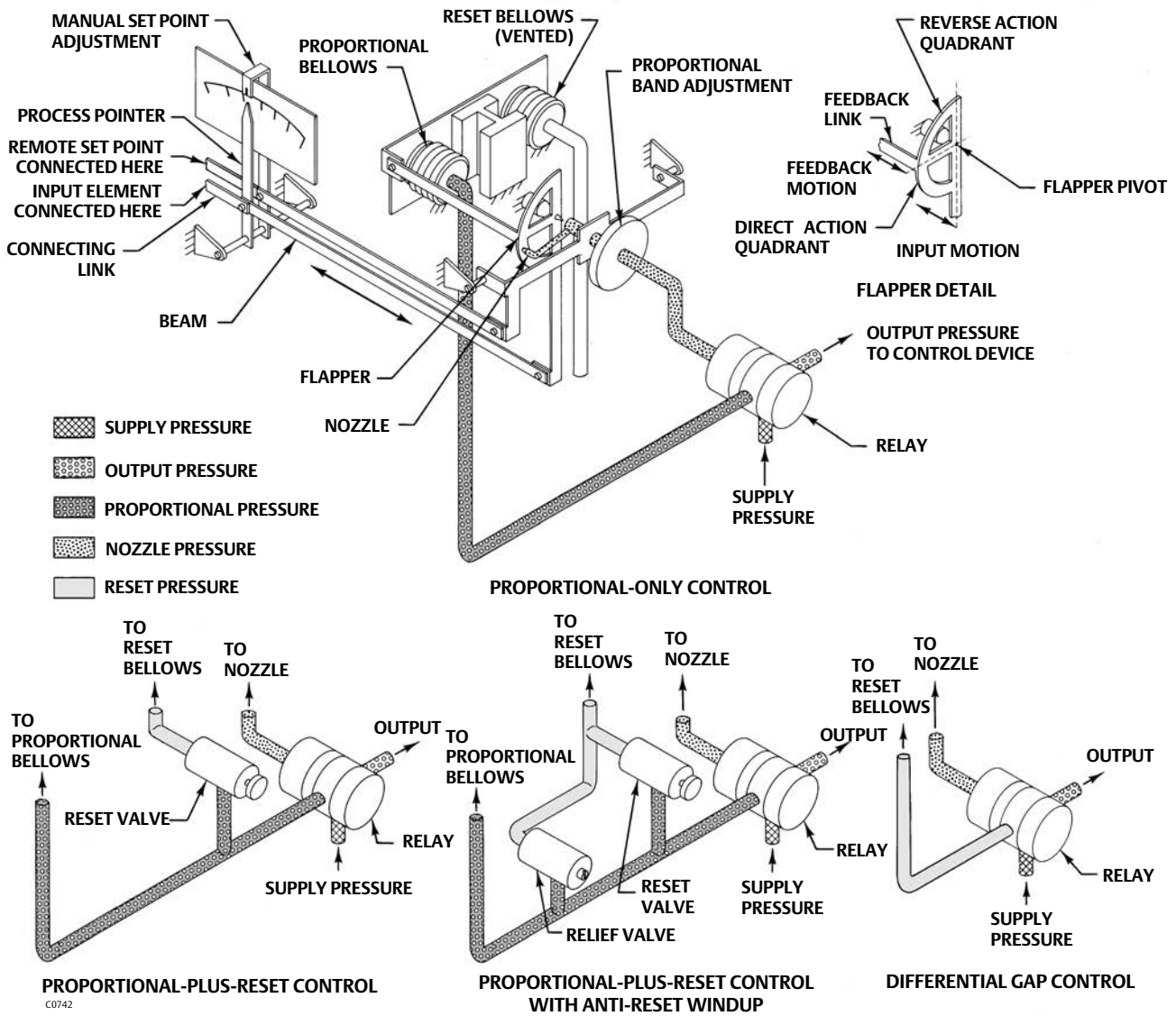

Principle of Operation

Refer to figure 1 (proportional-only control). The input element is connected to the process pointer and flapper by a connecting linkage. As the process differential pressure increases (in a direct-acting controller), the flapper moves toward the nozzle, restricting flow through the nozzle and increasing nozzle pressure. When this occurs, relay action increases the output pressure (delivery) of the controller. Output pressure is fed back to the

proportional bellows. The action of the proportional bellows counters the flapper movement that resulted from the process differential pressure change, and backs the flapper away from the nozzle. Set point adjustment also changes the proximity of the nozzle and flapper; however, when the set point is changed, the nozzle moves with respect to the flapper. When the controller is in the reverse-acting mode (see flapper detail in figure 1), an increase in process differential pressure causes a decrease in output pressure.

Figure 2. Controller Construction Detail

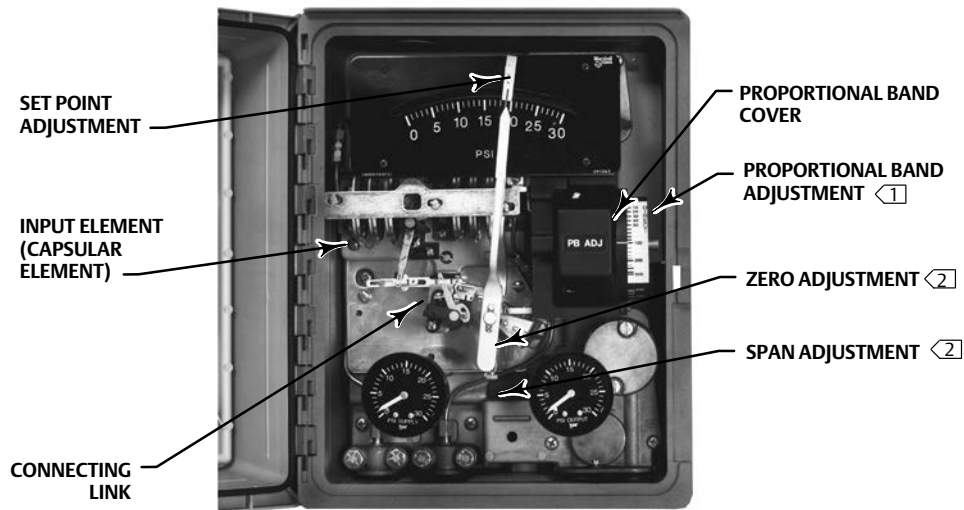

Notes:

① White portion of adjustment enables direct controller action; black portion enables reverse controller action.

② For the process pointer.

W3612-1

In addition to the proportional-only (4194A) version, a controller is available for proportional-plus-reset control (4194B). In this controller, output pressure is fed back to the reset bellows as well as to the proportional bellows.

Anti-reset windup is available on all controllers with reset. Remote set point is available on all controllers.

The 4194S controller provides differential gap control. In this version, feedback pressure is piped directly to the reset bellows, reinforcing the change in flapper position rather than counteracting it. This construction causes the controller output to switch from full supply pressure to zero pressure or vice versa.

The schematic diagram (figure 1) emphasizes detail of construction variations between control modes. Refer to table 1 for a complete description of type number suffixes.

Construction Features

Simplified Relay Maintenance

A clean-out wire provides a fast, easy means of cleaning the relay primary orifice during service.

Pressure Protection for the Case

A rubber plug in the plastic case pops out to prevent excessive pressure buildup from occurring inside the case before structural damage can take place.

Easy Direct/Reverse Switching

Controller action can be switched from direct to reverse or vice versa by simply loosening the screws on the proportional band cover and moving the cover out to rotate the proportional band knob to the desired action (see figure 2).

Figure 3. Typical Yoke Mounting

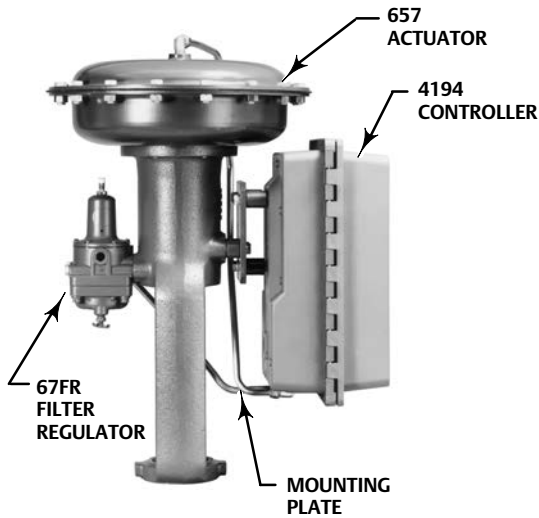

W5661

Easy Mode Conversion

Conversion from proportional to proportional-plus-reset control requires the addition of a reset valve and two pieces of tubing. Conversion from proportional to differential gap control requires the addition of one piece of tubing.

Anti-Reset Windup

Anti-reset windup is available with proportional-plus-reset controllers. Relief valve may be installed to limit reset windup in either direction.

Remote Set Point

The capability of adjusting the set point from a remote location is available as an option on 4194 controllers.

Auto/Manual Capability

An internal auto/manual station is available for smooth bumpless transfer from automatic to manual and manual to automatic control of the controller output.

Figure 4. Controller Dimensions

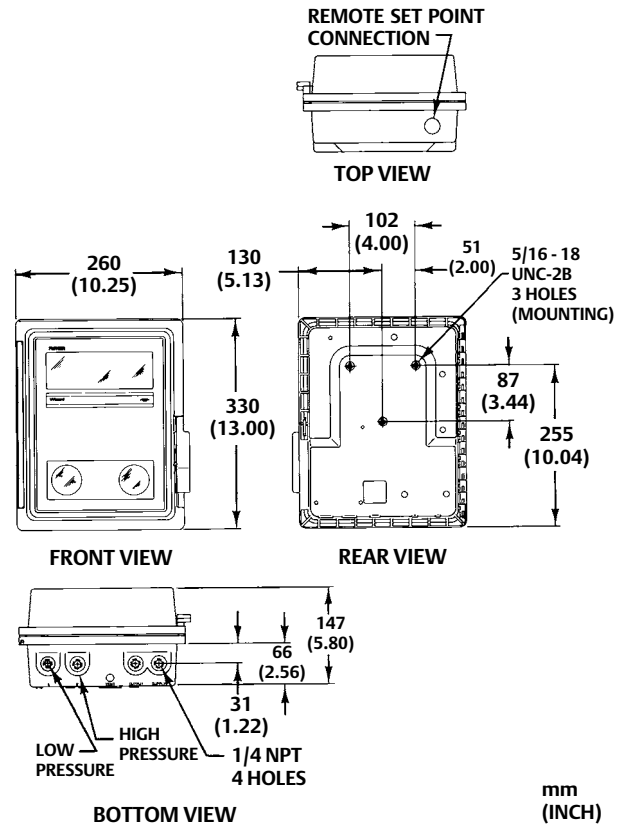

46A9765-A
A5710-1

Installation

The 4194 differential pressure controllers may be shipped alone for a separate installation or for installation on a control valve actuator. The controllers can also be mounted on a pipe stand, on a wall, or in a panel. When a controller is mounted on an actuator and a positioner is not used, the controller will usually be opposite the supply regulator as shown in figure 3. If a positioner is used, the supply regulator can be mounted on the actuator casing.

The controller must be installed so that the vent opening faces down. Basic controller dimensions are shown in figure 4. Dimensions for specific mounting methods are shown in figure 5.

Figure 5. Mounting Dimensions

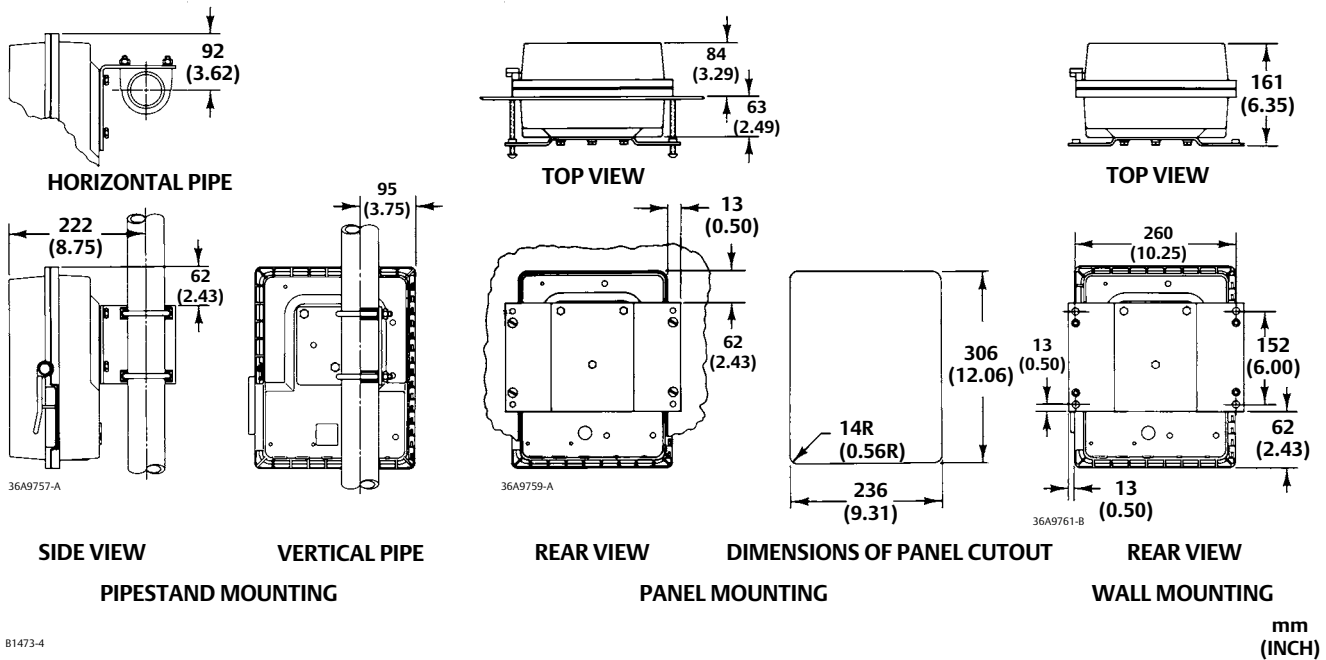

B1473-4

Ordering Information

When ordering, specify:

Application

1. Description of the service, such as throttling or on-off
2. Pressure range, composition, and temperature of process fluid
3. Ambient temperature

Construction

Refer to the specifications and the Construction Features section. Carefully review each specification and feature, indicating your choice whenever a selection is to be made. Refer to table 1 for type numbers; add R to any type number if reverse action is desired.

Neither Emerson, Emerson Automation Solutions, nor any of their affiliated entities assumes responsibility for the selection, use or maintenance of any product. Responsibility for proper selection, use, and maintenance of any product remains solely with the purchaser and end user.

Fisher is a mark owned by one of the companies in the Emerson Automation Solutions business unit of Emerson Electric Co. Emerson Automation Solutions, Emerson, and the Emerson logo are trademarks and service marks of Emerson Electric Co. All other marks are the property of their respective owners.

The contents of this publication are presented for informational purposes only, and while every effort has been made to ensure their accuracy, they are not to be construed as warranties or guarantees, express or implied, regarding the products or services described herein or their use or applicability. All sales are governed by our terms and conditions, which are available upon request. We reserve the right to modify or improve the designs or specifications of such products at any time without notice.

Emerson Automation Solutions
Marshalltown, Iowa 50158 USA
Sorocaba, 18087 Brazil
Cernay 68700 France
Dubai, United Arab Emirates
Singapore 128461 Singapore

www.Fisher.com

