

Fisher™ 3570 Pneumatic Valve Positioners

Contents

Introduction	1
Scope of Manual	1
Description	2
Valve Positioner Type Numbers	2
Specifications	4
Educational Services	4
Installation, Mounting, and Connections	5
Installation	5
Diagnostic Test Connections (Optional)	6
Connections	7
Piping Sizes	7
Vent	8
Supply Pressure Connections	9
Cylinder Connections	10
Instrument Connection	10
Operating Information	11
Initial Adjustments	11
Adjustment Procedures	11
Changing Positioner Action	12
Split Range Operation	15
Initial Range Spring Extension Procedure for 3570P and 3570PC Positioners	15
Principle of Operation	17
3570, 3570C, 3570P, 3570PC, and 3571 Valve Positioners	17
3572 and 3576 Valve Positioners	18
3573 and 3577 Valve Positioners	19
Relay Operation	20
Maintenance	21
Troubleshooting	22
Converting a 3570 Valve Positioner to a 3570C Valve Positioner	23
Range Spring	24
Disassembly	24
Assembly	24

Figure 1. Fisher 3570 Positioner Mounted on 470 Actuator



W5566

Bias Spring	25
Disassembly	25
Assembly	25
Parts Ordering	25
Parts Kits	26
Positioner Repair Kits	26
Diagnostic Test Connection Kits	26
Parts List	26
Positioner Common Parts	26

Introduction

Scope of Manual

This manual provides installation, operation, adjustment, maintenance, and parts ordering information for Fisher 3570 pneumatic valve positioners. The various product types within this series are described later in this manual. Refer

to figure 1 for a typical mounting of a 3570 positioner. Refer to separate instruction manuals for information concerning the actuator, valve, and accessories.

Do not install, operate or maintain a 3570 positioner without being fully trained and qualified in valve, actuator, and accessory installation, operation, and maintenance. To avoid personal injury or property damage, it is important to carefully read, understand and follow all the contents of this manual, including all safety cautions and warnings. If you have any questions about these instructions, contact your [Emerson sales office](#) or Local Business Partner before proceeding.

Description

3570 pneumatic valve positioners are used with control valve assemblies to provide an accurate valve stem position that is proportional to the input signal received from a control device. The input signal range can be 0.2 to 1.0 bar (3 to 15 psig), 0.4 to 2.0 bar (6 to 30 psig), or another pneumatic input signal range, as required.

These positioners are normally used with pneumatic piston actuators. However, product types within the 3570 family can be used with pneumatic, long-stroke, cylinder actuators or with pneumatic diaphragm actuators.

Valve Positioner Type Numbers

3570 — Pneumatic valve positioner with two relays for use with Fisher 470 and 480 pneumatic piston actuators. See figure 4. The positioner includes three pressure gauges to monitor input signal, relay output pressure to the top of the actuator cylinder, and relay output pressure to the bottom (piston underside) of the actuator cylinder.

The 3570 positioner is mounted on the top of the actuator cylinder. The actuator stem position feedback is provided through extension of the range spring attached to the actuator piston rod.

3570C — Pneumatic valve positioner with automotive tire valves instead of pressure gauges. Tire valves can be used for clip-on test pressure gauges. The relay nozzles are locked in place with locknuts to resist unwanted nozzle movement due to vibration.

3570P — Pneumatic valve positioner with two relays for use with Fisher 490 pneumatic piston actuators. The positioner includes three pressure gauges to monitor input signal, relay output pressure to the top of the actuator cylinder, and relay output pressure to the bottom (piston underside) of the actuator cylinder.

The 3570P positioner is mounted alongside the actuator cylinder. Actuator stem position feedback is provided from the actuator-valve stem connector through a cable and spool assembly.

3570PC — Pneumatic valve positioner with automotive tire valves instead of pressure gauges. Tire valves can be used for clip-on test pressure gauges. The relay nozzles are locked in place with locknuts to resist unwanted nozzle movement due to vibration.

3571 (Discontinued)— Pneumatic valve positioner with two relays for use with long-stroke cylinder actuators. The positioner includes three pressure gauges to monitor input signal, relay output pressure to the top of the actuator cylinder, and relay output pressure to the bottom (piston underside) of the actuator cylinder.

The 3571 positioner is bracket-mounted to the side of the actuator. Actuator stem position feedback is provided through a wire from the actuator-valve stem connector.

3572 — Pneumatic valve positioner with one relay. The 3572 positioner is normally used on the 472 pneumatic piston actuator mounted on valve bodies having push-down-to-open (PDTO) action. The positioner includes two pressure gauges to monitor input signal pressure and relay output pressure to the top of the actuator cylinder.

The 3572 positioner is mounted on the top of the actuator cylinder. Actuator stem position feedback is provided through an extension of the actuator piston rod.

Table 1. Specifications

Available Configurations

See the positioner type number descriptions given above.

Input Signal

Standard Ranges: 0.2 to 1.0 bar (3 to 15 psig) or 0.4 to 2.0 bar (6 to 30 psig)

Optional Ranges: As desired, within the limits of the bellows

Split Ranges: Use one-half of either standard range when two control valves are operated by one output signal from a single control device

Output Signal

Type: Pneumatic pressure as required to maintain the correct valve stem position and seat load

Action: Field-reversible between direct and reverse

Resolution⁽¹⁾

0.2% of instrument pressure span

Repeatability⁽¹⁾

0.3% of total stroke or instrument pressure span

Pressure Connections

Vent: 3/8 NPT

All others: 1/4 NPT

Pressure Indications

3570C and 3570CP Positioners: Tire valves accept standard pressure gauge chucks (gauges not supplied)

All Other Types: Gauges supplied per table 3

Bellows Pressure Rating

Standard Bellows: 3.4 bar (50 psig)

Optional Bellows: 6.2 bar (90 psig)

Supply Pressure

Maximum: 10.4 bar (150 psig)

Minimum: 2.4 bar (35 psig)

Supply Medium

Air or Natural Gas

Supply medium must be clean, dry, and noncorrosive

Per ISA Standard 7.0.01

A maximum 40 micrometer particle size in the air system is acceptable. Further filtration down to 5 micrometer particle size is recommended. Lubricant content is not to exceed 1 ppm weight (w/w) or volume (v/v) basis. Condensation in the air supply should be minimized

Per ISO 8573-1

Maximum particle density size: Class 7

Oil content: Class 3

Pressure Dew Point: Class 3 or at least 10°C less than the lowest ambient temperature expected

Steady-State Air Consumption⁽²⁾

0.54 normal m³/h (20 scfh) with 6.9 bar (100 psig) supply pressure

Operative Ambient Temperature Limits⁽¹⁾

With Nitrile O-Rings and Diaphragms: -34 to 71°C (-30 to 160°F)

With Fluorocarbon O-Rings and Diaphragms (Optional): 0 to 104°C (32 to 220°F)

Hazardous Area Classification

Complies with the requirements of ATEX Group II Category 2 Gas and Dust

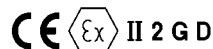

Meets Customs Union technical regulation TP TC 012/2011 for Groups II/III Category 2 equipment

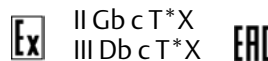

Options

- Restrictor (high-frequency filter for bellows)

Approximate Weight

2.7 kg (6 pounds) without optional mounting bracket or actuator/valve assembly

- continued -

Table 1. Specifications (Continued)

Declaration of SEP	Engineering Practice (SEP) and cannot bear the CE marking related to PED compliance.
Fisher Controls International LLC declares this product to be in compliance with Article 4 paragraph 3 of the PED Directive 2014/68/EU. It was designed and manufactured in accordance with Sound	However, the product <i>may</i> bear the CE marking to indicate compliance with <i>other</i> applicable European Community Directives.
<small>NOTE: Specialized instrument terms are defined in ANSI/ISA Standard 51.1 - Process Instrument Terminology. 1. For a 3570 or 3570C positioner mounted on a 470 or 480 actuator. Values do not apply to other constructions or actuator-valve combinations. 2. m³/h at 0°C, 1.01325 bar, absolute (Scfh at 60°F, 14.7 psia).</small>	

Table 2. Action Under Normal Operating Conditions

POSITIONER ACTION	DESIRED PISTON MOTION ⁽¹⁾	
	Down	Up
Direct-acting	Increasing input signal pressure to bellows	Decreasing input signal pressure to bellows
Reverse-acting	Decreasing input signal pressure to bellows	Increasing input signal pressure to bellows

1. Supply pressure is routed through relays to piston.

Table 3. Pressure Indications

PRESSURE MONITORED	NUMBER OF GAUGES SUPPLIED		STANDARD GAUGE RANGE ⁽¹⁾
	Two-Relay Positioner	One-Relay Positioner	
Positioner input signal pressure	1	1	0-30 psi/0-0.2 MPa/0-2 bar or 0-60 psi/0-0.4 MPa/0-4 bar
Cylinder (relay output) pressure	2	1	0-160 psi/0-1.1 MPa/0-11 bar

1. For gauges marked in other units and ranges, consult your [Emerson sales office](#).

3573 — Pneumatic valve positioner that is similar to The 3572 positioner with the relay output pressure piped to the bottom (piston underside) of the actuator cylinder. The 3573 positioner is normally used on the 473 pneumatic piston actuator with valve bodies having push-down-to-close (PDTTC) action.

3576 (Discontinued)— Pneumatic valve positioner with one relay for use on direct-acting pneumatic diaphragm actuators that require high operating pressures. The 3576 positioner includes two pressure gauges to monitor input signal pressure and relay output pressure to the top of the actuator diaphragm.

The 3576 positioner is bracket-mounted to the actuator yoke. Actuator stem position feedback is provided through a wire from the actuator-valve stem connector.

3577 (Discontinued)— Pneumatic valve positioner that is similar to 3576 positioner with the relay output pressure piped to the underside of the actuator diaphragm on reverse-acting pneumatic diaphragm actuators.

Specifications

Specifications for 3570 positioners are listed in table 1.

Educational Services

For information on available courses for 3570 positioners, as well as a variety of other products, contact:

Emerson Automation Solutions
Educational Services - Registration
Phone: 1-641-754-3771 or 1-800-338-8158
E-mail: education@emerson.com
emerson.com/fishervalvetraining

Installation, Mounting, and Connections

Installation

⚠ WARNING

- Always wear protective clothing, gloves, and eyewear when performing any installation operations to avoid personal injury.
- Personal injury or property damage may result from fire or explosion if natural gas is used as the supply medium and preventive measures are not taken. Preventive measures may include, but are not limited to, one or more of the following: Remote venting of the unit, re-evaluating the hazardous area classification, ensuring adequate ventilation, and the removal of any ignition sources. For information on remote venting of this positioner, refer to page 8.
- Check with your process or safety engineer for any additional measures that must be taken to protect against process media.
- If installing this into an existing application, also refer to the WARNING at the beginning of the Maintenance section of this instruction manual.

CAUTION

Do not use sealing tape on pneumatic connections. This instrument contains small passages that may become obstructed by detached sealing tape. Thread sealant paste should be used to seal and lubricate pneumatic threaded connections.

The positioner is usually mounted on the actuator at the factory. However, if the positioner and actuator are ordered separately, it is necessary to mount the positioner on the actuator. Before mounting the positioner, be certain the O-ring (key 33, figure 10) is in place in the cylinder (top connection) in the base of the positioner.

For appropriate actuator/positioner combinations, refer to the positioner type number descriptions given earlier in this instruction manual.

- For 3570, 3570C, 3572, and 3573 positioners, mount the positioner with two cap screws (key 32, figure 10). If the range and bias springs are not installed in the positioner, refer to the range spring and bias spring procedures in the Maintenance section.

Insert the threaded end of the spring retainer (key 19, figure 2) into the center of the range spring (see figure 2). Then, insert a screwdriver into the center of the range spring and extend the spring until the spring retainer can be screwed into the top of the actuator piston rod extension. Tighten the spring retainer into the top of the actuator piston rod extension. If the range spring and/or bias spring is not installed in the positioner, refer to the procedures for either spring in the Maintenance section.

- For 3570P and 3570PC positioners, attach the positioner extension and positioner to the cylinder mounting plate with the two cap screws (key 100, figure 13). Make the required pressure connections as described in the following procedure. Go to the initial range spring extension procedures for 3570P and 3570PC positioners.

Figure 2. Bias and Range Springs for Zero and Span Adjustments

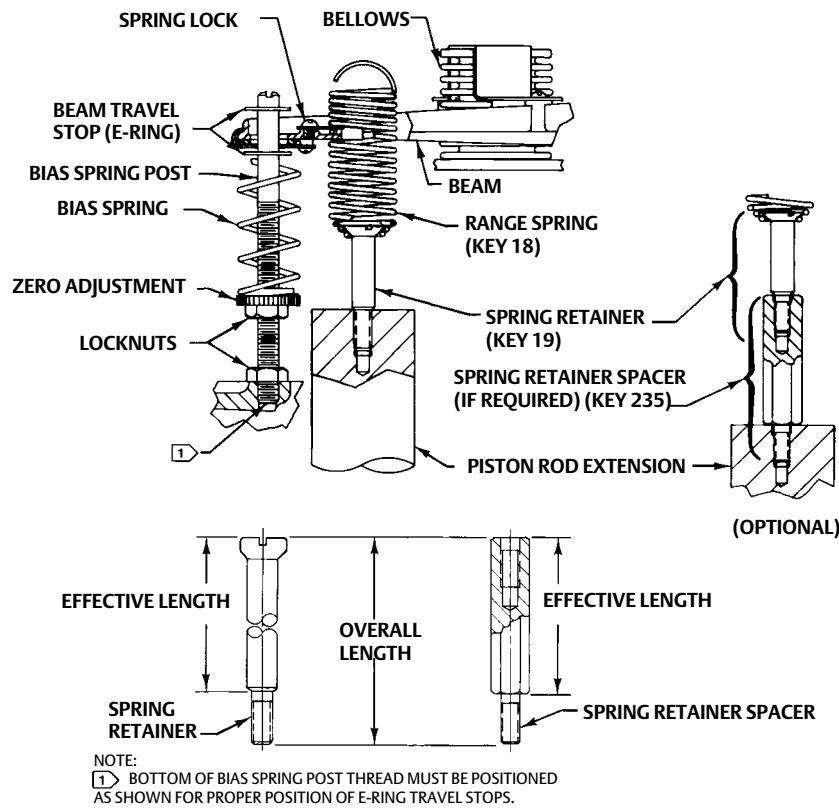

AJ7270-C
 1H8907-C
 1J2233-C
 B2402

Diagnostic Test Connectors (Optional)

Diagnostic test connectors are available from the factory, when the unit is ordered, or they can be installed on an existing control valve assembly in the field. These connectors are especially useful for “quick” connections when using the FlowScanner™ valve diagnostic system. The FlowScanner is a portable, microprocessor-based diagnostic and calibration system specifically designed for use with pneumatically-operated control valves.

To support diagnostic testing of the control valve assembly, the connectors, piping, and other hardware can be installed between the 3570 positioner and the actuator. A typical connector installation is shown in figure 3. For connectors, refer to the FlowScanner Diagnostic Connection kit listing in the parts list.

The hardware used includes 3/4 NPT pipe nipple, pipe tee, and pipe bushings with a 1/8 NPT pipe bushing for the connector. The connector consists of 1/8 NPT body and body protector (see figure 3).

1. Before assembling the pipe nipple, pipe tee, pipe bushings, actuator piping, and connector body, apply sealant to all threads.
2. Position the pipe tee, connector body, and body protector for easy access when doing diagnostic testing.

Figure 3. Diagnostic Test Connections

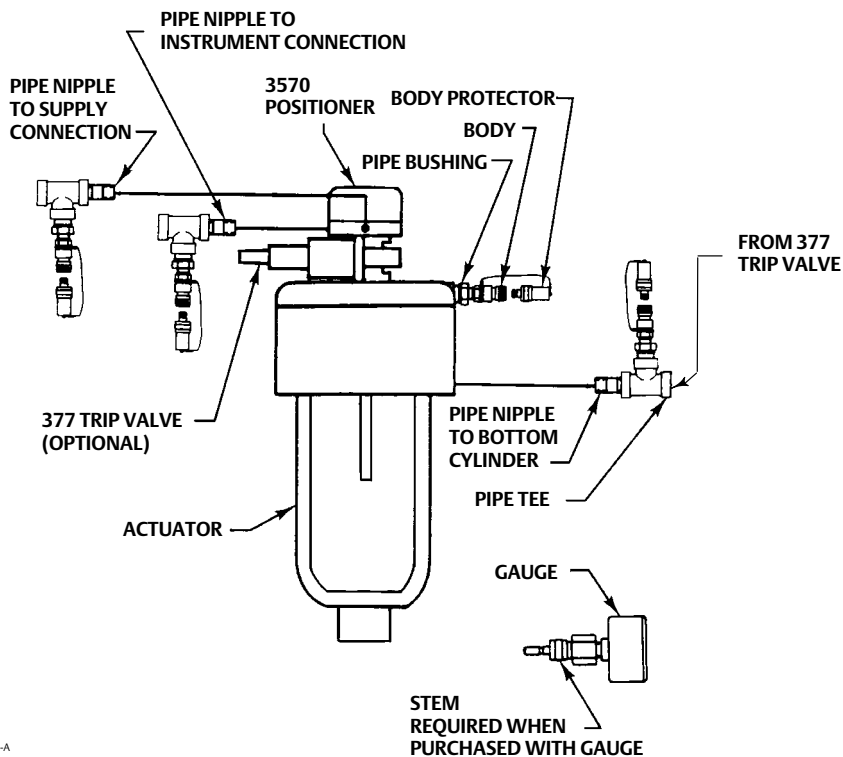

1288044-A
A6112

Connections

CAUTION

Do not use sealing tape on pneumatic connections. This instrument contains small passages that may become obstructed by detached sealing tape. Thread sealant paste should be used to seal and lubricate pneumatic threaded connections.

Piping Sizes

All pressure connections on 3570 positioners are 1/4 NPT (internal). Use 3/8-inch pipe or tubing for supply, cylinder (bottom connection), and instrument (input signal) connections. For the remote vent pipe, if one is required, use 19 mm (3/4-inch) (minimum inside diameter) pipe for runs up to 6.09 meters (20 feet). For vent piping runs from 6.09 to 30.5 meters (20 to 100 feet), use 25.4 mm (1-inch) (minimum inside diameter) pipe. Refer to figure 4 for the locations and sizes of connections.

Figure 4. Typical Location of Fisher 3570 Positioner Parts and Adjustments

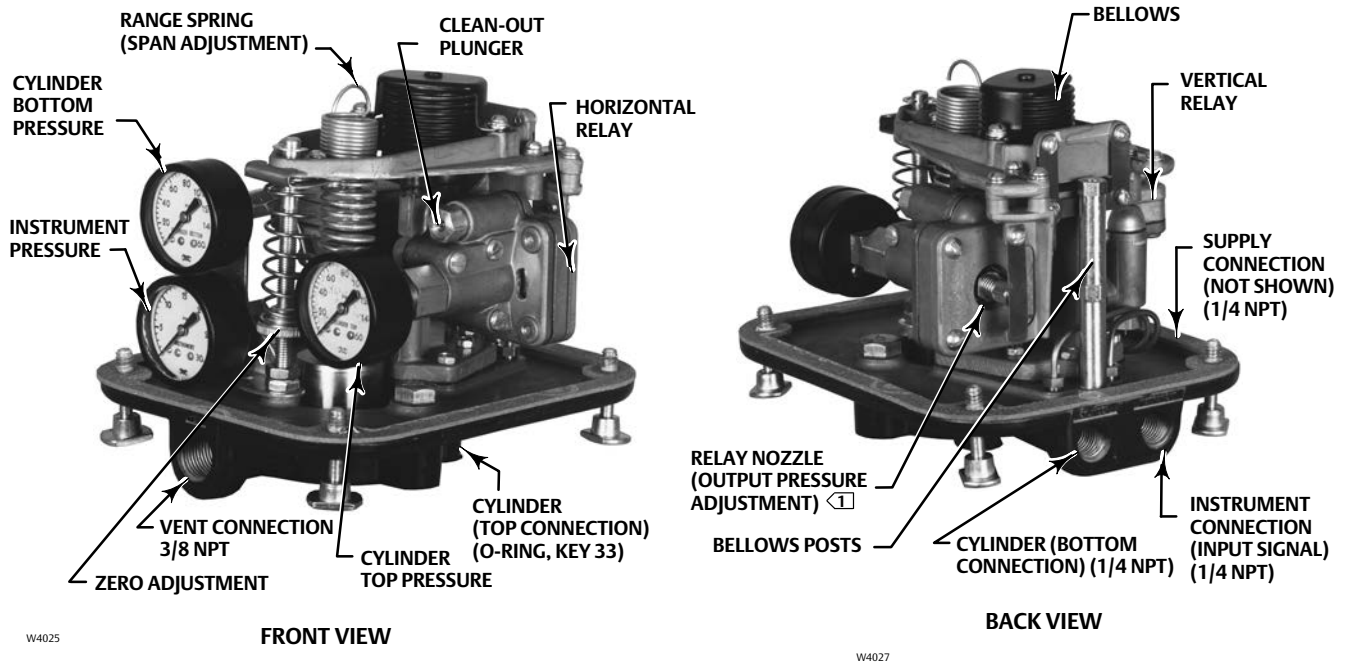

NOTES:
 [1] ON SOME CONSTRUCTIONS, TWO NOZZLES AND ADJUSTMENTS ARE REQUIRED.

Vent

⚠ WARNING

Personal injury or property damage could result from fire or explosion of accumulated gas, or from contact with hazardous gas, if a flammable or hazardous gas is used as the supply pressure medium.

The positioner/actuator assembly does not form a gas-tight seal, and flammable or hazardous gas could leak from the assembly. Therefore, if the assembly is enclosed install a remote vent line from the enclosure. However, a remote vent pipe alone cannot be relied upon to remove all hazardous gas. Use adequate ventilation, and necessary safety measures. Vent line piping should comply with local and regional codes and should be as short as possible with adequate inside diameter and few bends to reduce case pressure buildup.

CAUTION

When installing a remote vent pipe, take care not to overtighten the pipe in the vent connection. Excessive torque will damage the threads in the connection.

Note

The vent connection is always plugged with a pipe plug for 3570P and 3570PC positioners when mounted on 490 actuators.

The connection marked VENT (see figure 4) should be left open if the actuator is installed in the vertical position. However, the vent must be protected against the entrance of any foreign material that could plug it. Check the vent periodically to be certain it is not plugged.

If the actuator is mounted in other than the vertical position, be sure there is a vent and drain at the lowest point of the positioner. To do this, remove the pipe plug (key 36, figure 10) from the cover. Then, position the cover in such a way that the hole in the cover is at the lowest point. Plug the vent connection because the positioner is now vented through the cover.

Note

A remote vent is not possible with 3570P, 3570PC, 3571, 3576, and 3577 positioners.

If a remote vent is required, the vent line must be as short as possible with a minimum number of bends or elbows. Vent line piping should have a minimum inside diameter of 19 mm (3/4-inch) for runs up to 6.09 meters (20 feet) and a minimum inside diameter of 25.4 mm (1-inch) for runs from 6.09 to 30.5 meters (20 to 100 feet).

Supply Pressure Connections

⚠ WARNING

Personal injury or property damage may occur from an uncontrolled process if the supply medium is not clean, dry, oil-free air, or noncorrosive gas. While use and regular maintenance of a filter that removes particles larger than 40 micrometers in diameter will suffice in most applications, check with an Emerson field office and industry instrument air quality standards for use with corrosive air or if you are unsure about the proper amount or method of air filtration or filter maintenance.

⚠ WARNING

To avoid personal injury or property damage resulting from the sudden release of pressure, do not install the valve assembly where service conditions could exceed the limits given in this manual or on the appropriate nameplates. Use pressure-relieving devices as required by government or accepted industry codes and good engineering practices.

⚠ WARNING

If the supply pressure medium is corrosive, make sure the tubing and instrument components that contact the corrosive medium are of suitable corrosion-resistant material. The use of unsuitable materials might result in personal injury or property damage due to the uncontrolled release of the corrosive media.

The connection marked SUPPLY (see figure 4) must be provided with clean, dry air or a noncorrosive gas. Install a 40-micrometer filter and suitable equipment to dry the supply medium. Establish a maintenance cycle to ensure that the regulator and filter are working correctly.

CAUTION

The maximum allowable supply pressure to prevent damage to the components of the positioner, actuator, and valve is normally stamped on the actuator nameplate. Use a suitable supply pressure regulator to reduce the supply pressure source to the value stamped on the nameplate.

If this maximum supply pressure value is not available, use a supply pressure that does not exceed any of the following:

- The maximum supply pressure for the positioner as shown in table 1.
- The maximum pressure rating of the actuator, from the appropriate actuator instruction manual.
- The maximum allowable valve plug stem load for the specific valve body assembly being used. Contact your [Emerson sales office](#) or Local Business Partner for valve plug stem load information, if required.
- For diaphragm actuators, refer to the actuator instruction manual for the recommended supply pressure and use the larger value of the range listed.

The recommended supply pressure for use with piston actuators is the highest available supply pressure between 3.4 bar (50 psig) and the maximum limit determined by the actuator and positioner specifications. Selecting the highest pressure within the limits will minimize load error and will maximize stroking speed and thrust. For the lowest supply pressure that will assure satisfactory performance, the factors of valve plug unbalance force, valve plug seating force, and frictional force must be considered in the following relationship:

$$\text{Supply pressure, = 98 bar} \quad \left[\frac{\begin{array}{l} \text{(Valve} \\ \text{unbalance,} \\ \text{kg)} \end{array} + \begin{array}{l} \text{(Seating} \\ \text{force,} \\ \text{kg)} \end{array} + \begin{array}{l} \text{(Frictional} \\ \text{force,} \\ \text{kg)} \end{array} \right] + 0.7 \text{ bar}$$

(Area of the actuator piston,
in square mm)

or

$$\text{Supply pressure, = psig} \quad \left[\frac{\begin{array}{l} \text{(Valve} \\ \text{unbalance,} \\ \text{pounds)} \end{array} + \begin{array}{l} \text{(Seating} \\ \text{force,} \\ \text{pounds)} \end{array} + \begin{array}{l} \text{(Frictional} \\ \text{force,} \\ \text{pounds)} \end{array} \right] + 10 \text{ psig}$$

(Area of the actuator piston,
in square inches)

Consult your Emerson sales office for the appropriate values for specific actuators, valves, and service conditions. The 0.7 bar (10 psig) is added to the equation to account for an approximate 0.7 bar (10 psi) differential pressure loss in the positioner. For spring-return piston actuators, the pressure required to compress the actuator spring completely must also be considered.

Cylinder Connections

1. The connection marked CYLINDER (see figure 4) is connected at the factory to the lower part of the cylinder (bottom) or to the lower diaphragm casing if the positioner is used with a pneumatic diaphragm actuator.
2. The cylinder top connection is a pressure passage located in the bottom of the positioner base (key 1, figure 10). On 3570 and 3570C positioners, an O-ring (key 33, figure 10) is used between the bottom of the positioner and the top of the actuator.

Instrument Connection

The connection marked INSTRUMENT (see figure 4) connects to the output signal connection of the control device. The positioner operates only on a pneumatic input signal; the input signal range is marked on the nameplate (key 23,

figure 10). The maximum allowable input signal for positioners with standard or optional bellows is in table 1 (bellows pressure rating). The instrument connection is made at the factory when a complete control valve assembly with a valve-mounted control device is ordered. Otherwise, make field connections to the positioner from an appropriate control device. Refer to table 1 and the nameplate for input signal pressure ranges.

Operating Information

Initial Adjustments

Normally, no adjustments are necessary upon initial installation. The positioner is set at the factory for the travel, input signal range, and action specified in the order. Adjustment is necessary when operating conditions are changed, when the unit has been dismantled and reassembled, or when the control valve travel does not correspond to the desired input signal range. If the operating conditions have not changed but the positioner requires adjustment, refer to the adjustment procedures in this section. If the operating conditions have changed a new range spring, bias spring, and spring retainer/spacer may be required. Contact your [Emerson sales office](#) or Local Business Partner for assistance in determining if a new range spring, bias spring, and spring retainer/spacer are required. Refer to the Range Spring, Bias Spring, and Spring Retainer/Spacer Selection for 3570 Pneumatic Valve Positioners Instruction Manual Supplement ([D104021X012](#)).

Adjustment Procedures

Refer to figure 2. 3570 positioners have three adjustments:

- **The bias spring.** It is the zero adjustment which determines the starting point of the valve plug travel.
- **The range spring.** It is the span adjustment which determines the full valve plug travel for a given input signal range.
- **The relay nozzle adjustment.** This adjustment determines the steady-state positioner output pressure.

To illustrate the use of the various adjustments, assume that the positioner has been repaired or has become completely out of adjustment. Assume also that the input signal range is 0.2 to 1 bar (3 to 15 psig). Proceed as follows:

1. Make sure the input signal range and the valve travel stamped on the nameplate agree with the present operating conditions.
2. Loosen the four thumb screws on the underside of the positioner base and remove the cover.
3. Provide a means for varying the input signal pressure from zero to 0.07 or 0.14 bar (1 or 2 psig) above the higher value of the input signal range (see table 1). Provide an accurate means of measuring the input signal pressure. Check the accuracy of the positioner instrument pressure gauge (see figure 4). The gauge accuracy is ± 0.04 bar (± 0.6 psig) on a 0 to 2 bar (0 to 30 psig) gauge, and ± 0.08 bar (± 1.2 psig) on a 0 to 2 bar (0 to 60 psig) gauge. This accuracy is measured at the mid-point of the full range of the scale.
4. Set the input signal pressure at the mid-point of its range [0.6 bar (9 psig) in this example]. Observe the valve travel indicator scale attached to the yoke. The indicator disk should be somewhere between the open and closed positions.
5. Loosen the locknut directly below the bias spring seat (see figure 2) and adjust the bias spring up or down until the valve travel indicator disk shows that the valve plug is somewhere between the open and closed positions. Upward movement of the bias spring adjustment causes downward travel of the valve stem.

6. For positioners with two relays (3570, 3570C, 3570P, 3570PC, and 3571 positioners), observe the relay output pressures. If the cylinder gauges are present as shown in figure 4, read the cylinder top and cylinder bottom gauges or use clip-on test pressure gauges. The two relay output pressures should be approximately equal [within 0.3 bar (5 psig)] and should be approximately 75 percent of the supply pressure. For example, if the supply pressure is 7 bar (100 psig), the two relay output pressures should be within 0.3 bar (5 psig) of each other, and should be approximately 5.2 bar (75 psig).

CAUTION

The relays in the 3570C and 3570PC positioners use a locknut (key 29P, figure 10) on the nozzle (key 29Q). If the nozzle is rotated when the locknut is tight, damage to the relay diaphragm might result. Always use a wrench on the nozzle to prevent it from turning while loosening or tightening the locknut.

If the relay output pressures are not at the values mentioned, adjust the nozzles. Counterclockwise rotation of either nozzle will move the nozzle closer to the beam and will increase relay output pressure.

For all 3570 positioners, examine the end of the beam near the bias spring (see figure 2). The beam should be approximately centered between the two E-ring travel stops. Observing the caution above for 3570C and 3570PC positioners, rotate the nozzle(s) to center the beam between the E-rings. For positioners with two relays, the relay output pressures must be approximately equal [within 0.3 bar (5 psig)] and approximately 75 percent of supply pressure after the beam is centered.

7. Apply an input signal equal to the low value of the input signal range [0.2 bar (3 psig) in this example]. Adjust the bias spring (see figure 2) up or down until the valve travel is at the starting point.
8. Loosen the spring lock (see figure 2) and slowly increase the input signal toward the high end of the input signal range [1.0 bar (15 psig) in this example]. If the valve travel is less than its expected range, increase the travel by adjusting the range spring counterclockwise. If the valve travel reaches the end of its expected range with an input signal less than the high value of the input signal range, decrease the travel by adjusting the range spring clockwise.
9. Repeat steps 7 and 8 until the valve plug or travel indicator action corresponds to the input signal requirements of the application [0.2 to 1.0 bar (3 to 15 psig) in this example].
10. Lock the range spring and the bias spring seat in position. The positioner is then ready for operation.
11. If the positioner is unstable and adjustment does not correct the problem, it might be due to unwanted fluctuations in the input signal. A restrictor assembly (key 47, figure 10) can be installed in the input signal circuit to dampen these fluctuations. The restrictor might help to minimize instability. To take the restrictor out of service, exchange the location of the restrictor with that of the bellows mounting screw (key 46, figure 10).
12. Replace the cover (key 39) on the positioner.

Changing Positioner Action

The instructions given below are to be used after the springs have been changed or if no spring change is required. Numbered parts mentioned in this section are shown in figure 5 unless otherwise noted.

Figure 5. Bellows Mounting for Direct and Reverse Action

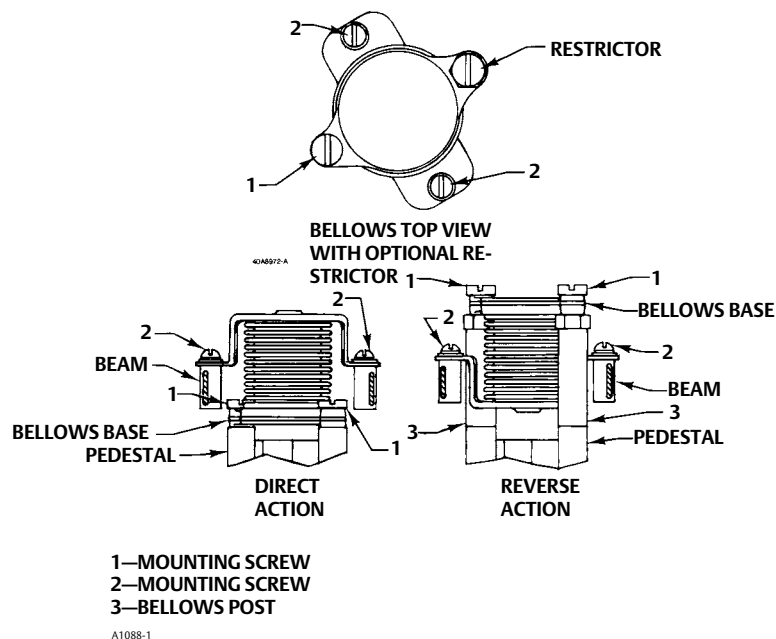

⚠ WARNING

The following procedures require taking the positioner, actuator, and control valve assembly out of service. To avoid personal injury or property damage caused by uncontrolled process pressure, provide a temporary means of control for the process before taking the assembly out of service.

Before removing the input signal and supply pressure connections from the positioner, remove the input signal and supply pressure sources from the connections. The sudden release of pressure can cause personal injury or property damage.

Note

Changing the positioner action might require changing the bias spring and/or the spring retainer. Contact your [Emerson sales office](#) or Local Business Partner for assistance in determining if a new bias spring and/or spring retainer are required. Refer to instruction manual supplement [D104021X012](#).

Changing to Reverse Action

1. Bypass the control valve and shut off the input signal line and the supply pressure line to the positioner.
2. Loosen the four thumb screws on the underside of the positioner base and remove the cover.

3. Two bellows posts are provided. The posts are screwed into storage holes in the positioner base immediately above the CYLINDER and INSTRUMENT connections. Unscrew these posts.

Note

An optional restrictor (see the top view in figure 5) can be found in place of one of the bellows mounting screws (number 1). If so, note the location of the restrictor and replace it in the same location during reassembly. The restrictor has a hex head; the mounting screws do not.

4. Remove the four mounting screws (numbers 1 and 2) and lift out the bellows assembly.
5. Screw the bellows posts (number 3) into the holes where the screws (number 1) originally were.
6. Invert the bellows and replace the screws (numbers 1 and 2).
7. Refer to the adjustment procedures to check operation of the positioner.
8. Make a notation on the action label (key 43, figure 10) that the action of the positioner has been changed.
9. Replace the cover (key 39) on the positioner.

Changing to Direct Action

1. Bypass the control valve and shut off the input signal line and the supply pressure line to the positioner.
2. Remove the positioner cover by loosening the four thumb screws on the underside of the base.

Note

An optional restrictor (see the top view in figure 5) can be found in place of one of the bellows mounting screws (number 1). If so, note the location of the restrictor and replace it in the same location during reassembly. The restrictor has a hex head; the mounting screws do not.

3. Remove the four mounting screws (numbers 1 and 2), bellows, and bellows posts (number 3).
4. Invert the bellows and reinstall it in the positioner. Secure the bellows with the four screws (numbers 1 and 2). Screw the bellows posts into the storage holes provided in the base immediately above the cylinder and instrument connections.
5. Refer to the adjustment procedures to check the operation of the positioner. If the input signal range has not been changed, adjustment of the range spring might not be necessary.
6. Make a notation on the positioner action label (key 43, figure 10) that the action of the positioner has been changed.
7. Replace the cover (key 39) on the positioner.

Split Range Operation

3570 valve positioners are suitable for split range operation. In split range operation, two or more control valves are operated by one output signal from a single control device. When two control valves are split ranged, one valve strokes fully with one half the input signal range and the second valve strokes fully with the other half of the input signal range.

Valve positioners shipped from the factory for split range operation are constructed and adjusted accordingly. If it is necessary to convert an existing positioner to one suitable for split range operation, consult your [Emerson sales office](#) or Local Business Partner to determine the new parts required (refer to instruction manual supplement [D104021X012](#)). For most changes, a new range spring and possibly a new bias spring will be required. A new range spring retainer might also be required for 3570, 3570C, 3572, and 3573 positioners.

When corresponding with your Emerson sales office, supply all information possible about the desired operating conditions and the serial numbers of the control valve assembly. This information will facilitate the proper selection of the required parts.

To change an existing valve positioner to one suitable for split range operation, refer to the range and bias spring removal and replacement procedures in the Maintenance section. Be certain the required new parts are on hand before beginning any maintenance operation.

Initial Range Spring Extension Procedures for 3570P And 3570PC Positioners

This procedure must be performed whenever the range spring has been changed or the positioner has been removed. Key numbers used in this procedure are shown in figure 13 except where indicated.

1. With the cap screw (key 87) removed, hook the small ball of the positioner cable (key 91) into the slot of the smaller portion of the cable spool (key 96). Wind the cable on the spool until the coils of the range spring (key 18, figure 10) are slightly separated. Be certain the cable is wound so that it comes off the side of the spool opposite the access opening and that the cable cannot cross itself on the spool.
2. Install the ball end of the actuator cable (key 92) into the slot of the large portion of the spool that is closer to the access opening. Wrap the cable on the spool as many times as possible, then bring the cable out through the bottom of the positioner extension. Be certain the cable is wound so that it comes off the side of the spool opposite the access opening and that the cable cannot cross itself on the spool. Attach the cable to the cable strap (key 93), leaving approximately a 0.8 mm (1/32-inch) gap between the cable eye and cap screw head (key 94).
3. With the actuator piston rod completely retracted and the range spring coils slightly separated, attach the cable strap to the actuator feedback arm. Use the set of cable-strap holes closest to the range spring. Turn the spring cap (key 86) one turn counterclockwise and install one cap screw (key 87).
4. Adjust the range spring (key 18, figure 10) to obtain full travel for the input signal range (span adjustment). Refer to step 7 of the adjustment procedures. Adjustment of the bias spring (zero adjustment) does not need to be done at this time.
5. Remove the screw from the spring cap and slowly release the torsion spring force by turning the spring cap clockwise. Disconnect the cable strap from the actuator and remove all range spring extension by rotating the cable spool.

6. Rotate the cable spool to obtain the correct initial range spring extension. Each full revolution of the spool extends the range spring 50.8 mm (2 inches) [6.4 mm (1/4-inch) for 1/8 revolution]. If the initial range spring extension is not specified, calculate it using one of the equations given below. Round off the amount of extension (e) obtained from the equation to the next higher 6.4 mm (1/4 inch).

$$e = \frac{T}{1.87 (P_n)} \quad (\text{standard bellows})$$

$$e = \frac{T}{1.25 (P_n)} \quad (\text{optional high pressure bellows})$$

where:

e = initial range spring extension required in mm

T = actuator travel in mm

P_n = input signal span in bar (for example, 0.8 bar for a 0.2 to 1 bar input signal range)

or where:

e = initial range spring extension required in inches

T = actuator travel in inches

P_n = input signal span in psi (for example, 12 psi for a 3 to 15 psig input signal range)

7. If necessary, move the actuator cable ball to the spool slot nearer the access opening. With the actuator piston rod fully retracted and the range spring at the correct initial extension, attach the cable strap to the actuator feedback arm. Use the set of cable strap holes that is closest to the tapped holes in the feedback arm.
8. Refer to the positioner adjustment procedures.

Principle of Operation

3570, 3570C, 3570P, 3570PC, and 3571 Valve Positioners

Refer to the schematic diagram in figure 6. The pneumatic output signal from a control device is piped to the positioner bellows. For explanation purposes, assume this signal has increased. The bellows expands and moves the beam, which pivots around a fixed point and simultaneously uncovers the nozzle of relay B and covers the nozzle of relay A. The nozzle pressure in relay A increases due to the restriction created by the beam covering the nozzle. Through relay action, the pressure to the top of the piston increases. At the same time, relay B reacts to the change in beam position to decrease the pressure to the underside of the piston. These unbalanced pressures move the actuator piston down.

In the 3570 and 3570C positioners, the piston movement is fed back to the beam by means of a range spring, which is connected to the beam and to the piston rod extension. In the 3570P, 3570PC, and 3571 positioners, the feedback is provided to the range spring by a cable or wire that is connected to the actuator-valve stem connector. The downward movement of the piston rod extension extends the range spring until the torque on the beam balances the torque exerted by the instrument bellows.

Figure 6. Schematic Diagram of Fisher 3570 Positioner with a 470 Pneumatic Piston Actuator

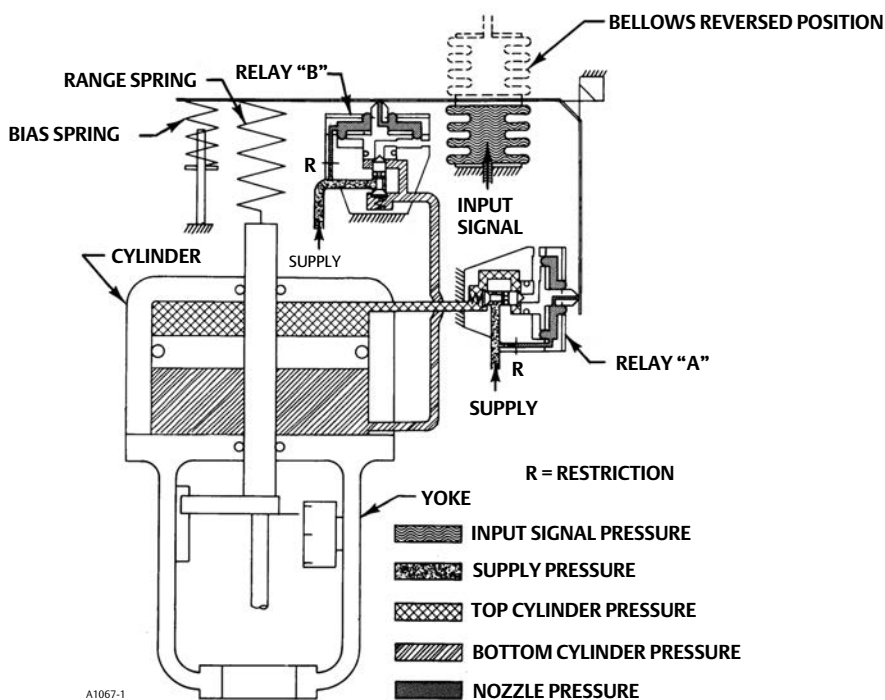

As the input signal decreases, the reverse action takes place. The bellows contracts, and as the beam pivots, it covers the nozzle of relay B and uncovers the nozzle of relay A. Through relay action, the pressure below the piston increases and the pressure above the piston decreases to move the piston upward.

3572 and 3576 Valve Positioners

Refer to the schematic diagram in figure 7, which shows the 3572 positioner mounted on a 472 pneumatic piston actuator. For the 3576 positioner, the principle of operation is identical to the 3572 positioner but the actuator can be a direct or reverse acting pneumatic diaphragm actuator.

Figure 7. Schematic Diagram of Fisher 3572 Positioner with a 472 Pneumatic Piston Actuator

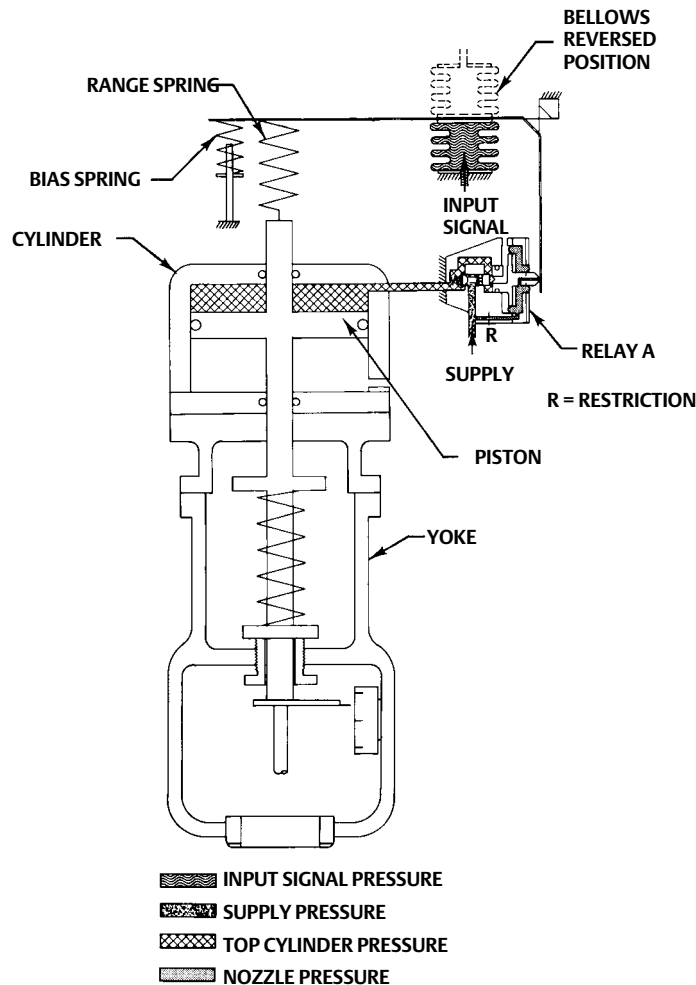

CR4006-A
A1084-1/L

The pneumatic output signal from a control device is piped to the positioner bellows. For explanation purposes, assume this signal has increased. The bellows expands and moves the beam, which pivots around a fixed point and covers the relay nozzle. The nozzle pressure in the relay increases due to the restriction created by the beam covering the nozzle. Through relay action, the pressure above the piston overcomes the force exerted by the actuator spring, and the piston moves downward. This changes the valve plug position.

In the 3572 positioner, piston movement is fed back to the beam by means of a range spring, which is connected to the beam and the piston rod extension. As the piston rod extension moves downward, the range spring is extended until the torque of the beam balances the torque exerted by the instrument bellows.

In the 3576 positioner, the feedback is provided to the range spring by a wire that is connected to the actuator-valve stem connector.

As the input signal decreases, the reverse action takes place. The bellows contracts, and as the beam pivots, it uncovers the relay nozzle. Through relay action, the pressure on top of the piston decreases, and the force of the actuator spring moves the piston upward.

3573 and 3577 Valve Positioners

Refer to the schematic diagram in figure 8, which shows the 3573 positioner mounted on a 473 pneumatic piston actuator. For the 3577 positioner, the principle of operation is identical to the 3573 positioner, but the actuator can be direct or reverse acting.

Figure 8. Schematic Diagram of Fisher 3573 Positioner with 473 Pneumatic Piston Actuator

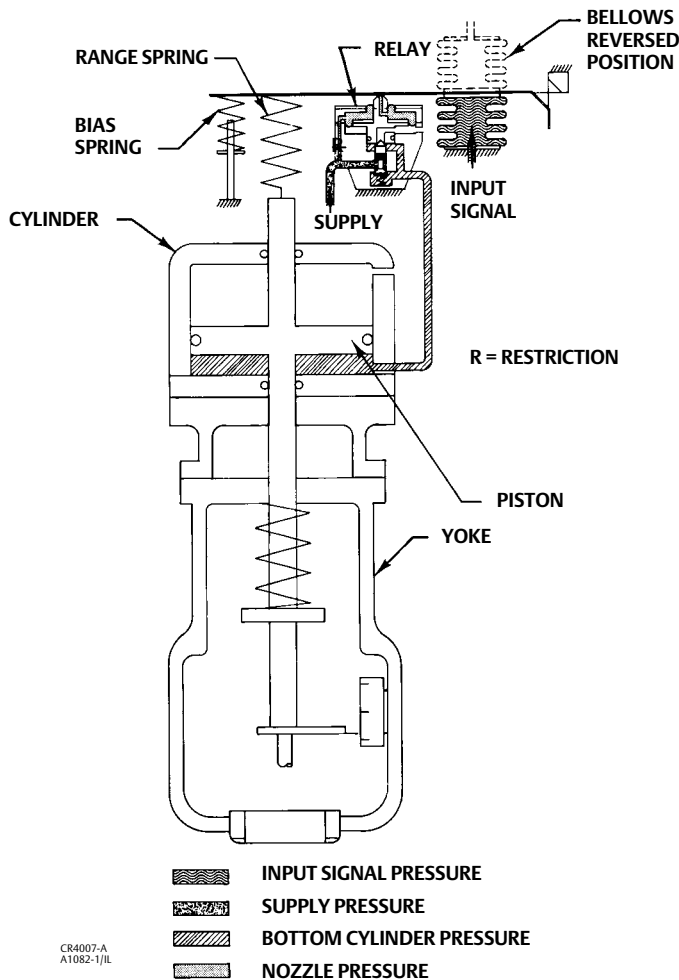

The pneumatic output signal from a control device is piped to the positioner bellows. For explanation purposes, assume this signal has increased. The bellows expands and moves the beam, which pivots around a fixed point and uncovers the relay nozzle. The nozzle pressure decreases due to the uncovering of the nozzle by the beam. Through

relay action, the pressure to the underside of the piston decreases. The force exerted by the actuator spring overcomes the force of the pressure below the piston, and the piston moves downward. This changes the valve plug position.

In the 3573 positioner, piston movement is fed back to the beam by means of a range spring, which is connected to the piston rod extension. The downward movement of the piston rod extension extends the range spring until the torque of the beam balances the torque exerted by the instrument bellows.

In the 3577 positioner, feedback is provided to the range spring by a wire that is connected to the actuator-valve stem connector.

As the input signal decreases, the reverse action takes place. The bellows contracts, and as the beam pivots, it covers the relay nozzle. Through relay action, the pressure on the underside of the piston increases to overcome the force exerted by the actuator spring, and the piston moves upward.

Relay Operation

Refer to figure 9, which shows a sectional view of a typical relay.

Supply pressure reaches the relay(s) through passages in the positioner base and is channeled to fixed restriction R and to point A between the supply valve B and the balancing O-ring of the relay valve. The fixed restriction is an integral part of the relay restriction plug and wire assembly G. The orifice in nozzle F is larger than the fixed restriction. This allows the supply pressure to bleed to atmosphere faster than it enters the unit through the fixed restriction when the beam flapper is away from the nozzle.

Assume that a change in the input signal causes the beam flapper to cover the nozzle of a relay. The supply pressure flows through fixed restriction R into the chamber between the two relay diaphragms. Due to the restricting effect of the flapper over the nozzle, pressure builds up in the chamber between the diaphragms, forcing the diaphragm head assembly E downward to open supply valve B, allowing output pressure to increase.

The supply pressure flows past supply valve B to increase the output pressure to the actuator cylinder. The cylinder pressure (relay output pressure) also acts on the area D. This provides an air feedback that returns the diaphragm head assembly E and the movable nozzle F to their original positions, thus preventing any further increase in output pressure. The feedback arrangement and the movable nozzle ensure accurate and stable positioning of the actuator piston without introducing cycling or over-correction. After any change in the output pressure, supply valve B and exhaust valve C always return to the closed position to put the nozzle back in its original, or equilibrium, position. The spring behind supply valve B aids in closing the valve as the diaphragm head assembly is forced upward.

When the beam flapper moves away from the nozzle F, the supply pressure bleeds out at a greater rate than it enters through the fixed restriction R. The pressure then decreases in the chamber between diaphragms. The force of the cylinder pressure acting on area D pushes diaphragm head assembly E upward, opening exhaust valve C. Cylinder pressure bleeds through the exhaust port to atmosphere. As the cylinder pressure decreases and the force on area D decreases, the force of the nozzle pressure in the chamber between the diaphragms returns the assembly to its original position. The unit is again in equilibrium, but at a lower nozzle pressure and a lower output pressure.

Each relay has a 4:1 ratio between the nozzle pressure and the output pressure. For example, a 0.7 bar (10 psig) nozzle pressure change, produces a 2.7 bar (40 psig) output pressure change; a 1.4 bar (20 psig) nozzle pressure change produces an 5.5 bar (80 psig) output pressure change. With a constant input signal pressure, the internal parts of the relay are at equilibrium with the supply and exhaust valves closed.

Figure 9. Sectional View of a Typical Relay

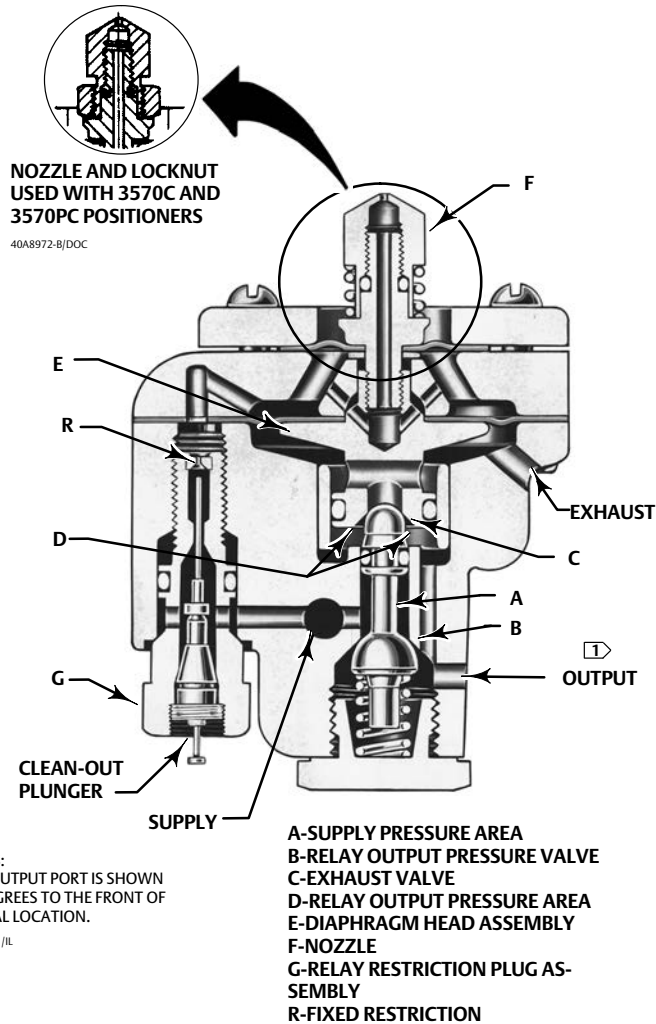

Maintenance

Parts are subject to normal wear and must be inspected periodically and replaced as necessary. The frequency of parts inspection and replacement depends upon the severity of service conditions. When inspection or repairs are required, disassemble only those parts necessary to accomplish the task.

⚠ WARNING

Avoid personal injury from sudden release of process pressure. Before performing any maintenance operations:

- Always wear protective clothing, gloves, and eyewear.

- Do not remove the actuator from the valve while the valve is still pressurized.
- Disconnect any operating lines providing air pressure, electric power, or a control signal to the actuator. Be sure the actuator cannot suddenly open or close the valve.
- Vent the power actuator loading pressure and relieve any actuator spring precompression.
- Use lock-out procedures to be sure that the above measures stay in effect while you work on the equipment.
- Personal injury or property damage may result from fire or explosion if natural gas is used as the supply medium and preventive measures are not taken. Preventive measures may include, but are not limited to, one or more of the following: Remote venting of the unit, re-evaluating the hazardous area classification, ensuring adequate ventilation, and the removal of any ignition sources. For information on remote venting of this positioner, refer to page 8.
- Check with your process or safety engineer for any additional measures that must be taken to protect against process media.

Troubleshooting

If the positioner causes sluggish or erratic operation or the malfunctioning of the actuator, first, be certain that the range springs, bias springs, and spring retainer are correct for the application. Consult your [Emerson sales office](#) or Local Business Partner to determine if a new range springs, bias springs, and spring retainer are required. Refer to instruction manual supplement [D104021X012](#).

If the springs and spring retainer are correct, and careful adjustment of the unit does not produce smooth and satisfactory operation, check the following points. Key numbers used in this procedure are shown in figure 10 except where indicated. Figure 4 shows part locations.

1. Clean out the primary orifice on each relay by depressing the clean-out plunger. The plunger is located in the orifice assembly (key 29S). This operation runs a fine wire through the orifice to clear the hole.
2. Check the nozzle (key 29Q) of each relay for plugging. To clean, swing the flapper (key 12) away from the nozzle by loosening the screw that holds the flapper in place.

CAUTION

The relays used in 3570C and 3570PC positioners use a locknut (key 29P, figure 11) on the nozzle (key 29Q, figure 11). If the nozzle is rotated when the locknut is tight, damage to the relay diaphragm will result. Always use a wrench on the nozzle to prevent it from turning while loosening or tightening the locknut.

Unscrew the nozzle and run a fine wire through it. Do not enlarge the hole. Also check the surface of the flapper for any accumulation of dirt or foreign materials.

3. Check the bellows assembly for damage, misalignment, or leakage. Also check all gasketed joints for leakage. Use soap solution for leak detection.
4. Check the beam for damage, binding or rubbing against stationary parts. Check the flexure strip screws (key 17) for tightness.
5. If the positioner operation has improved, refer to the adjustment procedures.
6. If the relays require replacement, go to step 7.
7. Unscrew the three machine screws (key 31) from each relay and remove the relays.

8. Mount the relays in their respective positions on the positioner pedestal, making certain that the relay gasket (key 30) is in good condition and is in place.
9. If the positioner operation is still sluggish, a slight adjustment of the bias spring post (see figure 2) might be necessary. Loosen the locknut and rotate the post in half-turn increments, checking after each half turn for proper operation. Rotate the post no more than two turns from the position shown in figure 2. Refer to the adjustment procedures after rotating the post to check the position of the post and beam assemblies.

Converting a 3570 Valve Positioner to a 3570C Valve Positioner

If desired, tire valves can be substituted for pressure gauges. Also, locking relay nozzles can be added on any 3570 positioner. This provides the construction that is standard with 3570C and 3570PC positioners.

Key numbers used in this procedure are shown in figure 10 except where indicated. When reassembling, coat all pipe threads with a good quality pipe thread compound.

1. Isolate the control valve from the line pressure and release pressure from both sides of the valve body. If using a power actuator also shut-off all pressure lines to the power actuator and release all pressure from the actuator. Use lock-out procedures to be sure that the above measures stay in effect while you work on the equipment.
2. Loosen the knurled screws (key 38) and remove the cover (key 39).
3. Disconnect the tubing assemblies (keys 28 and 45) from the base and from the gauges (keys 24 and 25). Unscrew the hex nuts (key 27) from the back of the gauges and remove the gauges (keys 24 and 25).
4. Unscrew the pressure gauge (key 54) from the gauge adaptor (key 29U).
5. Unscrew and remove the nozzle and spring (keys 29Q and 29P) from each relay.
6. The gauge bracket (key 5) can be removed if desired. To remove it, loosen the locknut (key 7) and remove the bias spring post and cap screw (keys 6 and 32). When replacing the bias spring post, be sure that the bottom of the post thread is positioned as shown in figure 2 for proper positioning of the E-ring travel stops. This alignment can be verified visually through the vent port.
7. Use compression plugs (key 52) to plug the holes opened in the base when the tubing is removed.

CAUTION

Never rotate the nozzle (key 29Q) when the locknut (key 29P) is tight, or damage to the relay diaphragm will result. Always use a wrench on the nozzle to prevent it from turning while loosening or tightening the locknut.

8. Install the locknut and nozzle (keys 29P and 29Q) on each relay.
9. Install the tire valve (key 26, figure 11) into the gauge adaptor (key 29U).
10. Install the service tee and tire valve adaptor (keys 49 and 53, figure 11) into the CYLINDER connection. Connect the pressure line that runs to the lower part of the cylinder to the service tee.
11. Install the pipe nipple, pipe tee, and tire valve adaptor (keys 50, 51, and 53, figure 11) into the INSTRUMENT connection. Connect the input signal line to the pipe tee.
12. Refer to the adjustment procedures.

Range Spring

Disassembly

Unless otherwise directed, key numbers refer to figures 10 and 11.

⚠ WARNING

The following procedure requires taking the positioner, actuator, and control valve assembly out of service. To avoid personal injury or property damage caused by uncontrolled process pressure, provide a temporary means of control for the process before taking the assembly out of service.

Before removing the input signal and supply pressure connections from the positioner, remove the input signal and supply pressure sources from the connections. The sudden release of pressure can cause personal injury or property damage.

1. Bypass the control valve and shut off the input signal and the supply pressure lines to the positioner.
2. Remove the positioner cover (key 39).
3. Loosen the spring lock (see figure 2) that holds the range spring (key 18) to the beam.
4. Disconnect the other end of the range spring by performing one of the following steps:
 - For 3570, 3570C, 3572, and 3573 positioners, use a screwdriver to remove the spring retainer (key 19, figure 2) from the piston rod extension.
 - For 3570P and 3570PC positioners (see figure 13), remove the screws (key 87), from the cap (key 86) and rotate the cap clockwise to remove all torsion spring force. Disconnect the actuator cable (key 92) from the cable strap (key 93). Unhook the positioner cable (key 91) from the cable spool (key 96).
5. Remove the range spring from the beam by rotating the range spring counter clockwise.

Assembly

1. Install the new range spring. For 3570, 3570C, 3572, and 3573 positioners, also install the spring retainer. See figures 2 or 10.
2. Reconnect the range spring to the piston rod extension (3570, 3570C, 3572, and 3573 positioners) or the feedback wire (3571, 3576, and 3577 positioners, figure 12). For 3570P and 3570PC positioners, install the positioner cable (key 91, figure 13) in the range spring so that the large ball on the cable seats in the conical portion of the spring.
3. Install the spring lock (key 20, figure 10). Adjust the positioner per instructions in the adjustments procedures.

The action of the positioner can be reversed in the same manner as described in the changing positioner action procedures. However, before attempting to reverse the action consult your [Emerson sales office](#) or Local Business Partner to determine if any different parts are required. Refer to instruction manual supplement [D104021X012](#).

Bias Spring

Disassembly

1. Refer to figure 2. Remove the top E-ring travel stop.
2. Loosen the locknut securing the bias spring seat in place. Then rotate the adjusting screw until the spring force is at a minimum.
3. Loosen the locknut that secures the bias spring post to the positioner base. Using a screwdriver in the slot in the top of the post, unscrew the post from the base.
4. Tilt the bottom of the post out and remove the post from the beam.
5. Remove the locking nuts and the spring seat from the bias spring post.

Assembly

1. Install the new bias spring, spring seat, and locking nuts on the bias spring post.
2. Replace the bias spring post into the beam and install the top E-ring travel stop.
3. Install the bias spring post into the base. Be certain that the bottom of the post thread is positioned as shown in figure 2. Ensure that the beam does not rub on the post.
4. For 3570P and 3570PC positioners, go to the initial range spring extension procedures for 3570P and 3570PC positioners.
5. Adjust the positioner as described in the adjustments procedures.

The action of the positioner can be reversed in the same manner as described in the changing positioner action procedures. However, before attempting to reverse the action consult your Emerson sales office or Local Business Partner to determine if a different retainer, different range springs or different bias springs are required. Refer to instruction manual supplement [D104021X012](#).

Parts Ordering

A serial number is assigned to each positioner. The serial number is stamped on the nameplate. Always refer to the serial number when corresponding with your [Emerson sales office](#) or Local Business Partner regarding spare parts or technical information.

⚠ WARNING

Use only genuine Fisher replacement parts. Components that are not supplied by Emerson Automation Solutions should not, under any circumstances, be used in any Fisher instrument. Use of components not supplied by Emerson may void your warranty, might adversely affect the performance of the valve, and could cause personal injury and property damage.

Parts Kits

Note

Parts kits for 3570 positioners contain the gaskets, diaphragms, and O-ring seals as specified by the type and temperature limitations. Parts are for 3570, 3570C, 3570P, and 3570PC positioners.

Positioner Repair Kits

Description	Part Number
Positioner kit includes: Keys 3, 12, 29 (qty. 2), 30, 33, and 37	
For the 3570	R3570X00022
For the 3570C	R3570CX0022
For the 3570C (hi-temp. const.)	R3570CX0H32

Diagnostic Test Connection Kits

Note

Contact your Emerson sales office or Local Business Partner for Part Ordering information.

Kit includes pipe tee, pipe nipple, pipe bushings, connector body, and body protector used with the FlowScanner.

For Diaphragm Actuators
For Piston Actuators

Pipe Thread Sealant (not furnished with hardware or connectors)

Parts List

Positioner Common Parts (figures 10 and 11)

Note

Contact your [Emerson sales office](#) or Local Business Partner for Part Ordering information.

Key	Description	Part Number
1	Pilot base	
2	Pedestal	
3*	Pedestal gasket	
4	Machine screw (5 req'd)	
5	Gauge bracket For all types except 3570C	
6	Bias spring post	
7	Hex nut (2 req'd)	
8	Spring seat (use with key 48 only)	
9	Bias Spring, extension type Color Code: Black Pink Dark green	
10	Retaining ring (2 req'd)	
11	Beam	
12	Flapper (2 req'd)	
13	Flapper arm	
14	Horizontal flexure strip (2 req'd)	
15	Vertical flexure strip	
16	Machine screw (2 req'd)	
17	Machine screw For 3570, 3570C, 3571 (12 req'd) For 3572, 3573, 3576, 3577 (11 req'd)	
18	Range Spring	
19	Spring retainer	
20	Spring lock	
21*	Bellows assembly To 3.4 bar (50 psig) High pressure bellows over 3.4 bar (50 psig)	
22	Bellows post (2 req'd)	
23	Name plate	
24*	Instrument gauge, plastic case/brass wetted parts For all types except 3570C 0-30 psi/0-.2 MPa/0-2 bar 0-60 psi/0-.4 MPa/0-4 bar	21B4037X012 21B4037X022
25*	Cylinder bottom gauge, plastic case/brass wetted parts For 3570, 3571, 3573, 3577 0-160 psi/0-1.1 MPa/0-11 bar	21B4037X032

Figure 10. Fisher 3570 Positioner

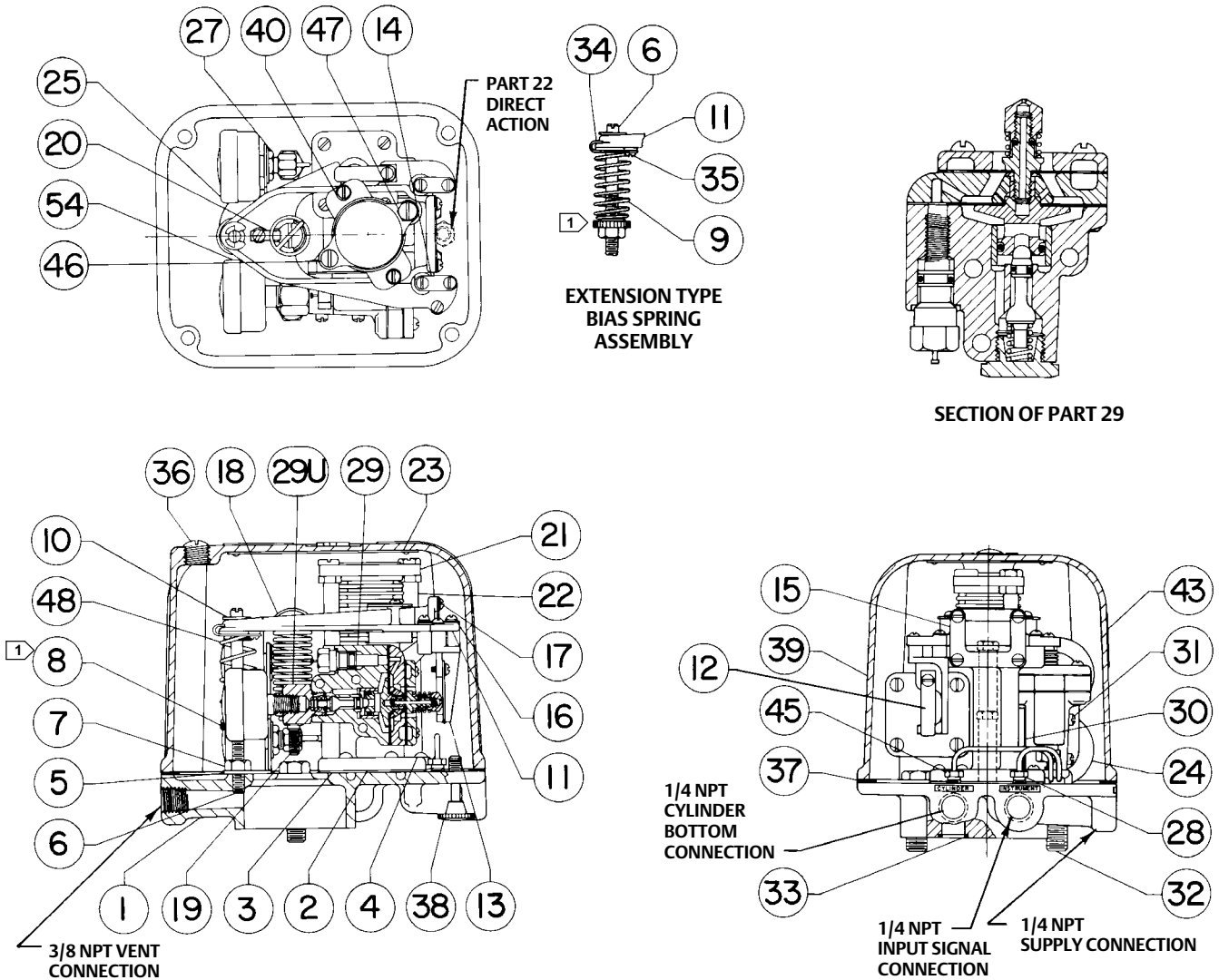

NOTE:

☐ ZERO ADJUSTMENTS IS PART OF KEY 9 FOR EXTENSION TYPE BIAS SPRING.

40A8973-C
B1840

Key	Description
26	Valve Assembly For 3570C only
27	Hex nut For 3570, 3571, 3573 (2 req'd) For 3572, 3576, 3577 (1 req'd) For 3570C (none req'd)
28	Instrument tubing assembly For all types except 3570C
29	Relay assembly, included in Repair Kits

Key	Description
30	Relay gasket, (2 req'd)
31	Machine screw For 3570, 3570C, 3571 (6 req'd) For 3572, 3573, 3576, 3577 (3 req'd)
32	Cap screw(2 req'd)
33*	O-ring

*Recommended spare parts

Figure 11. Fisher 3570C Positioner

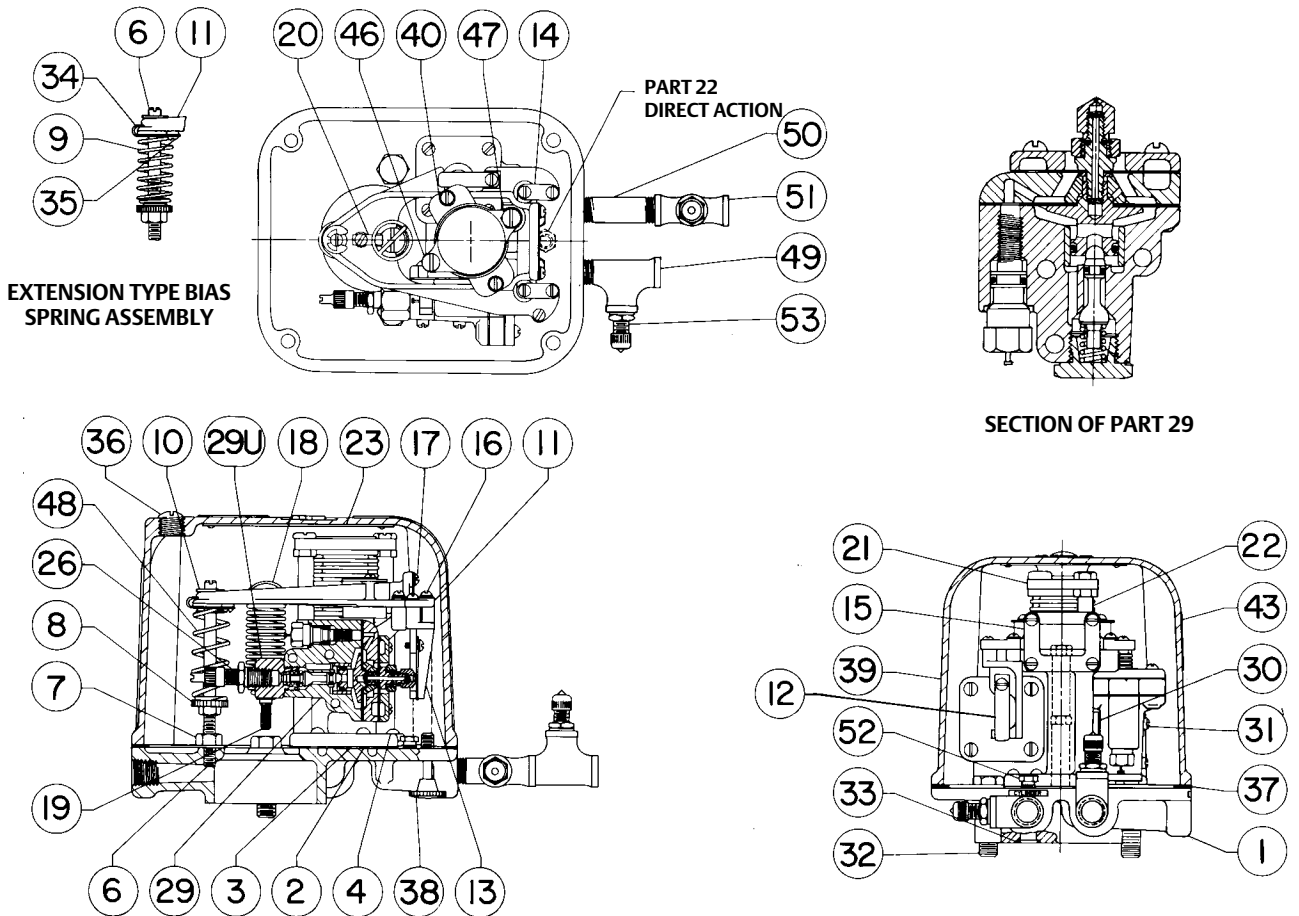

40A8972-B
B1841

Key	Description
34	Spring anchor
35	Machine screw (2 req'd)
36	Pipe plug
37*	Cover gasket
38	Cover screw (4 req'd)
39	Cover
40	Washer (2 req'd)
41	Relay blank (see figure 12) For 3572, 3573
42	Screw (see figure 12) For 3572, 3573

Key	Description
43	Label For direct-acting units For reverse-acting units
45	Cylinder tubing assembly For 3570, 3571, 3573, 3577
46	Bolt w/o restrictor assembly (2 req'd) w/restrictor assembly (1 req'd)
47	Restrictor assembly

Key	Description	Part Number
48	Bias spring, compression type Color Code: Silver Light blue Red Light green Brown	
49	Service tee For 3570C only	
50	Pipe nipple For 3570C only	
51	Pipe tee For 3570C only	
52	Compression plug, For 3570C only (2 req'd)	
53	Adaptor For 3570C only (2 req'd)	
54*	Cylinder top gauge, plastic case/brass wetted parts, For 3570, 3571, 3572, 3576 triple scale, 0-160 psi/0-1.1 MPa/0-11 bar dual scale, 0-160 psi/0-11 kg/cm ²	11B4040X032 11B4040X062
75	Tubing (specify length)	
77	Elbow, 3/8-inch (specify quantity)	
78	Connector, 3/8-inch (specify quantity)	
84	Spring retainer spacer	

Figure 12. Typical Fisher 3572 and 3573 Positioner

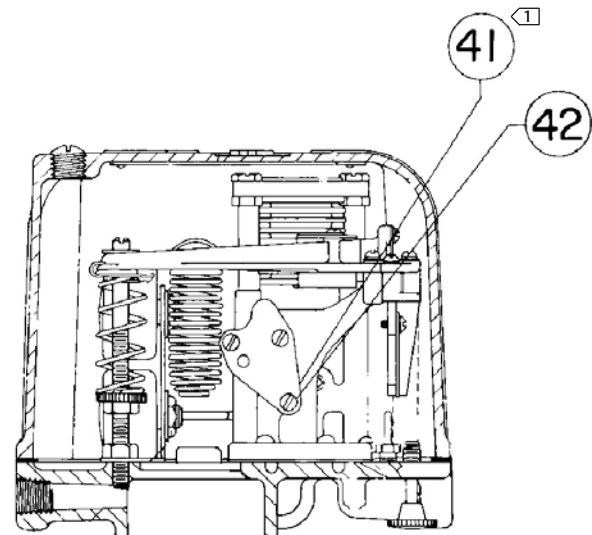

NOTE:
 [1] RELAY BLANK AND SCREWS (KEY 42 AND 42) ARE INSTALLED WHERE SHOWN FOR 3573 POSITIONERS. FOR 3572 POSITIONERS, THESE PARTS ARE INSTALLED ON THE OPPOSITE SIDE OF THE POSITIONER

Note

Refer to figure 13 for keys 86 through 101.

86	Spring cap assembly	
87	Machine screw (2 req'd)	
88	Torsion spring	
89	Extension cover	
90	Machine screw (6 req'd)	
91	Positioner cable	
92	Actuator cable	
93	Cable strap	
94	Cap screw (3 req'd)	
95	Hex nut	
96	Cable spool	
97	Spring guide	
98	Warning plate	
99	Self-tapping screw	
100	Cap screw (2 req'd)	
101	Positioner extension assembly	

Key	Description
102	Washer For 3572, 3576 (1 req'd) For 3570, 3571, 3573, 3577 (2 req'd)
235	Spring retainer spacer 104.8 mm (4-1/8 inches) maximum actuator travel, 54.0 mm (2-1/8 inches) or less valve travel 206.4 mm (8-1/8 inches) maximum actuator travel, between 54.0 mm (2-1/8 inches) and 104.8 mm (4-1/8 inches) valve travel (2 different spacers req'd) 206.4 mm (8-1/8 inches) maximum actuator travel, less than 54.0 mm (2-1/8 inches) valve travel (2 req'd)

Figure 13. Fisher 3570P and 3570PC Positioner

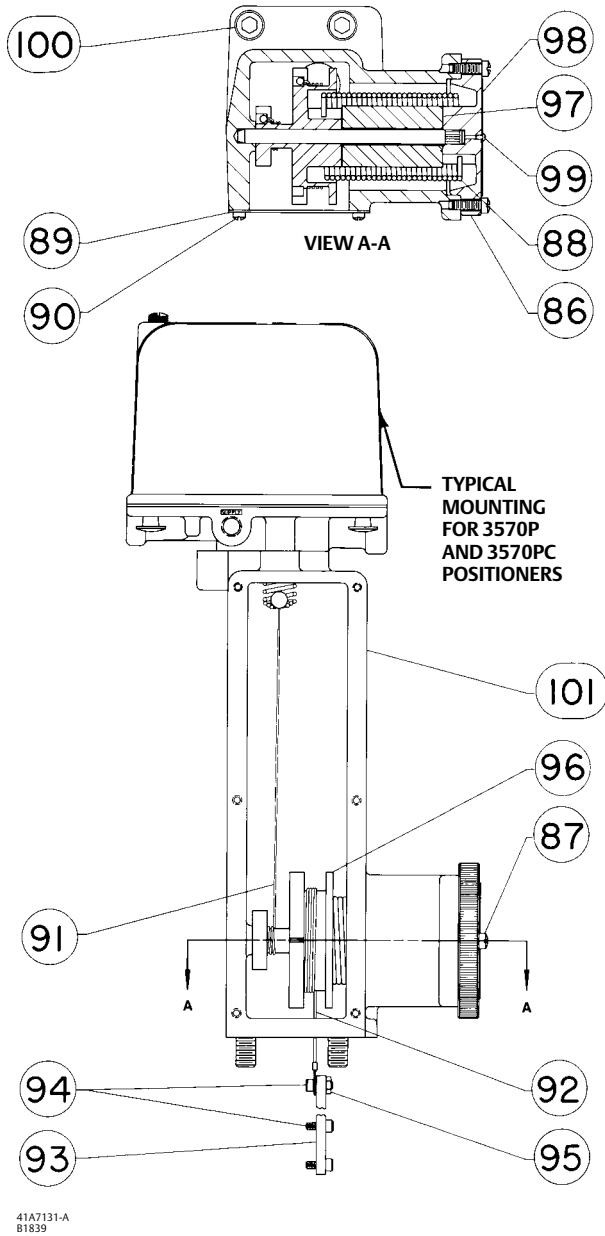

Neither Emerson, Emerson Automation Solutions, nor any of their affiliated entities assumes responsibility for the selection, use or maintenance of any product. Responsibility for proper selection, use, and maintenance of any product remains solely with the purchaser and end user.

Fisher and FlowScanner are marks owned by one of the companies in the Emerson Automation Solutions business unit of Emerson Electric Co. Emerson Automation Solutions, Emerson, and the Emerson logo are trademarks and service marks of Emerson Electric Co. All other marks are the property of their respective owners.

The contents of this publication are presented for informational purposes only, and while every effort has been made to ensure their accuracy, they are not to be construed as warranties or guarantees, express or implied, regarding the products or services described herein or their use or applicability. All sales are governed by our terms and conditions, which are available upon request. We reserve the right to modify or improve the designs or specifications of such products at any time without notice.

Emerson Automation Solutions

Marshalltown, Iowa 50158 USA

Sorocaba, 18087 Brazil

Cernay, 68700 France

Dubai, United Arab Emirates

Singapore 128461 Singapore

www.Fisher.com

