

Fisher™ 2052 Diaphragm Rotary Actuator

Fisher 2052 spring-and-diaphragm rotary actuators are used on rotary-shaft valve bodies for throttling or on-off applications. The 2052 may be used for throttling service with a positioner, or it may be used for on-off service without a positioner. The 2052 has an ISO 5211 mating interface that allows installation to non-Fisher valves. Refer to separate bulletins for valve and positioner information.

Features

- **Compact design, smaller actuators**-- Ensures reduced valve/actuator envelope dimensions leading to greater mounting versatility for both skids and process plants, where space is at a premium.
- **Compatible with DVC2000, DVC6200, and DVC6000 digital valve controllers; and 3610J and 3620J positioners**-- The new actuator allows linkage-less feedback, via a contact-less magnetic array, from the lever to the end-mounted DVC2000. Integral window mounting of the DVC6200, DVC6000, 3610J, and 3620J is also available.
- **Clamped lever to reduce lost motion**-- The clamping of the lever onto a splined valve shaft, coupled with the single pivot linkage, reduces lost motion between the actuator and the valve. The typical cumulative deadband for a Fisher rotary control valve assembly results in 0.5% or less variability.
- **No bench set required**-- The new nested spring design requires no bench set. This also simplifies the actuator selection process, see table 3.
- **ISO 5211 mounting with optional insert**-- The actuator can now be mounted directly onto non-spline shafts, such as Square and Double D. This allows the actuator, with its enhanced control, to mount on a wider range of valves conforming to ISO 5211.
- **Adjustable travel stops standard**-- Provides the ability to adjust or change the travel range by 30 degrees in either direction without removing the actuator or the addition of extra parts.
- **Fail-safe mechanism contains no aluminum**-- All parts in the fail-safe mechanism (made of steel, cast iron, and ductile iron) ensure the actuator will maintain safety integrity in the event of a fire.
- **Powder paint as standard**-- The Emerson powder paint finish offers an excellent corrosion-resistant finish to all external steel and cast iron parts.
- **NAMUR VDE/VDI 3845 bolt pattern for accessory mounting**-- Meeting the global standard ensures compatibility for most accessories, enabling quick and easy mounting.
- **Field reversible, right- or left-hand mounting**-- The actuator/valve assembly action can be converted from push-down-to-open to push-down-to-close, or vice-versa, without additional parts.
- **Declutchable and top-mounted handwheels**-- Available for all sizes.



W9418-2

Fisher Control-Disk™ Valve with 2052 Actuator and FIELDVUE™ DVC6200 Digital Valve Controller

2052 Actuator Specifications and Materials of Construction

Table 1. Fisher 2052 Actuator Specifications

Specifications	
Actuator Mounting Connections	Splined shaft connection, ISO 5211 actuator-to-bracket connection Size 1: F07, Size 2: F10, Size 3: F14
Actuator Sizes	See table 3
Operating Pressure ⁽¹⁾	See table 5
Maximum Diaphragm Casing Pressure	Size 1, 2, and 3 Actuators: 5 barg (73 psig)
Pressure Connection	See table 4
Torque Output	See table 5
Actuator Temperature Capabilities ⁽¹⁾	Standard: -45 to 80°C (-50 to 176°F) Optional: -45 to 100°C (-50 to 212°F) ⁽³⁾ or -60 to 80°C (-76 to 176°F) ⁽⁴⁾
Operation	Field reversible between PDTC and PDT0; right- and left-hand mounting, any angle of orientation
Approximate Weight	Size 1: 22.2 kg (49 lb) Size 2: 54.4 kg (120 lb) Size 3: 113 kg (250 lb)
Controller/Positioners Available	DVC2000, DVC6020, DVC6030, DVC6200, 3610J, 3620J, 4190, C1
Adjustable Travel Stops	Standard adjustable up and down stops capable of 30 degrees of adjustment per stop.
Accessories Available	846, 646, 2625, and 67C Series, switches, i2P-100, VBL, DXP, GO Switch™
Handwheel	Top-mounted handwheel: Optional on Size 1, 2, and 3 actuators Declutchable handwheel ⁽²⁾ : Optional on Size 1, 2, and 3 actuators
Operational Lockout ⁽²⁾	Available for customer-supplied padlock to lock the actuator in the spring-fail position
<p>1. The pressure/temperature limits in this bulletin should not be exceeded. The current SIL certification for the 2052 actuator is only relevant for the standard temperature ratings shown.</p> <p>2. Lockout and declutchable handwheel cannot be used together on size 2 and size 3 actuators.</p> <p>3. Temperature range only applies when using silicone diaphragm material. Silicone diaphragm is not available with the top-mounted handwheel option.</p> <p>4. Temperature range requires use of stainless steel bolting for yoke and travel stops. Not available with top-mounted handwheel.</p>	

Table 2. Materials of Construction

Component	Material
Top Casing	Steel
Housing	Cast Iron
Diaphragm	Nitrile and nylon standard, Silicone on polyester
Lever	Ductile iron
Diaphragm Plate	Cast iron
OPTIONAL TOP-MOUNTED HANDWHEEL ASSEMBLY	
Component	Material
Handwheel	Cast iron
Handwheel Stem	Aluminum-Bronze
Top Casing Assembly	Steel
O-ring	Nitrile
Pusher Plate	Steel

Contents

Features 1
 2052 Actuator Specifications and Materials
 of Construction 2
 Options 3

Tables
 Actuator and Shaft Size Availability 5
 Torque versus Actuator Size 6
 Pressure Connections 6
 Dimensions 6
 Mounting Style 11

Options

Top-Mounted Handwheel: For infrequent use as a manual actuator (see figure 2). For repeated or daily manual operation, the unit should be equipped with a declutchable handwheel actuator.

Declutchable Handwheel Actuator: An end-mounted manual actuator can be used to provide on-site control and to provide override capabilities. See Fisher 1078 Declutchable Manual Actuator bulletin ([D101339X012](#)) for handwheel actuator specifications. The declutchable handwheel is not compatible with the lockout option on the size 2 and size 3 actuators.

Limit Switches: ■ Micro-Switch or NAMCO switches for one or two single-pole, double-throw contacts, or ■ GO Switch™ proximity switches for one or two single-pole, double-throw contacts are available. See separate bulletins for limit switch information.

Position Indicating Switch: TopWorx™ DXP M21GNEB switch for one through six single pole, double throw switch contacts are available. See separate bulletin for position indicating switch information.

Positioner: For precise positioning of the valve control element, the actuator should be equipped with a positioner. For additional information, contact your [Emerson sales office](#) or Local Business Partner with complete service conditions.

Optional Lockout Option: An actuator locking mechanism is available, which can be used to keep the actuator in a locked position (the same as the spring-fail position) during maintenance. The padlock is customer supplied. The lockout option on the size 2 and size 3 actuators is not compatible with the declutchable handwheel.

Cold Service Construction: For services with ambient temperatures down to -60°C (-76°F). This construction is suitable for cold climate regions per GOST 15150. Contact your Emerson sales office or Local Business Partner for details. Note that the current SIL certification for the 2052 actuator is only relevant for the standard temperature ratings shown in table 1. Not available with the top-mounted handwheel option.

Tandem Linkage: Fisher three-way valve assemblies for converging and diverging throttling or on/off service. Valves are operated by a single actuator through a tandem linkage, typically arranged so that one of the valves is opening while the other is closing. Consult your Emerson sales office or Local Business Partner for additional details on sizing, selection, and installation.

Figure 1. Fisher 2052 Assembly

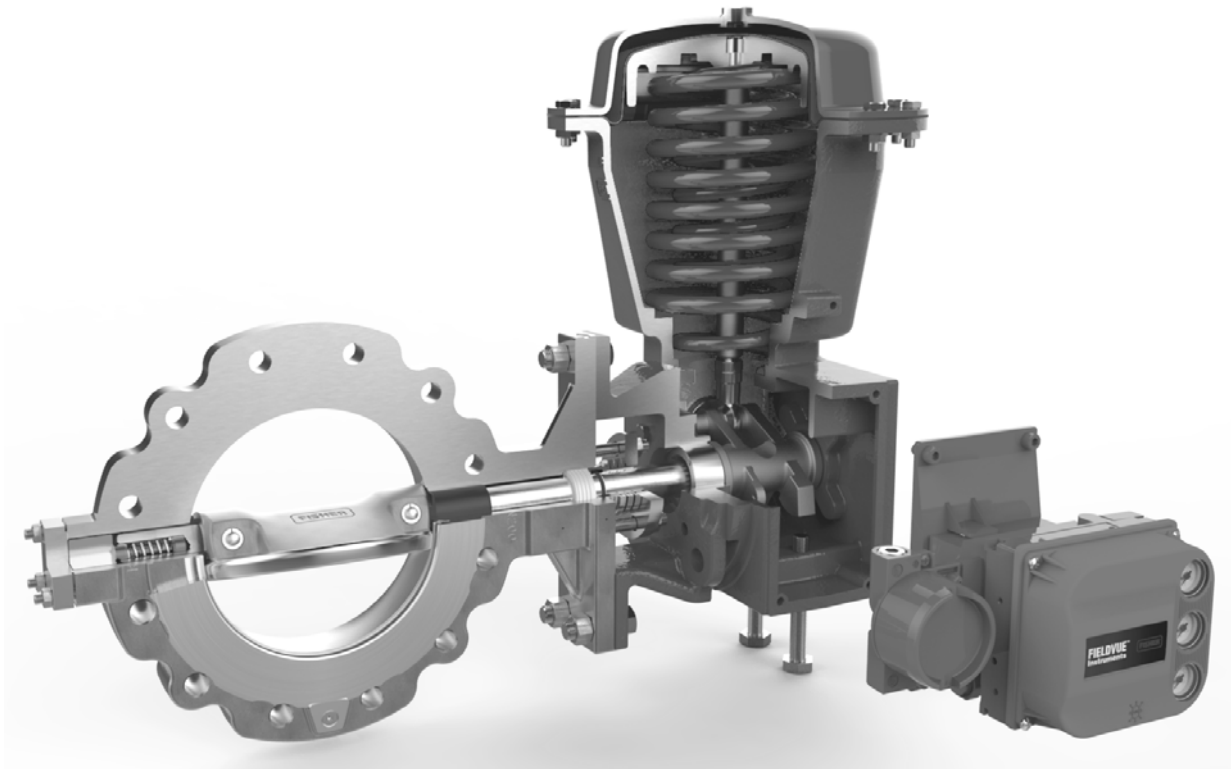

Figure 2. Top-Mounted Handwheel



W9484

Table 3. Actuator and Shaft Size Availability

SHAFT SIZE		ACTUATOR SIZE		
mm	Inches	1	2	3
12.7	1/2	X		
14.3 x 15.9	9/16 x 5/8	X	X	
15.9	5/8	X	X	
19.1	3/4	X	X	X
22.2	7/8		X	X
25.4	1		X	X
28.6 x 31.8	1-1/8 x 1-1/4		X	X
31.8	1-1/4		X	X
31.8 x 38.1	1-1/4 x 1-1/2			X
38.1	1-1/2			X
39.7 x 44.5	1-9/16 x 1-3/4			X
44.5	1-3/4			X
50.8	2			X

Table 4. Pressure Connections

ACTUATOR SIZE	PRESSURE CONNECTION			
	1/4 NPT	1/2 NPT	3/4 NPT	G 1/4
1	standard	optional	not available	optional
2	standard	optional	not available	optional
3	not available	standard	optional	not available

Table 5. Torque versus Actuator Size

ACTUATOR SIZE AND ACTION	OPERATING PRESSURE							
	2 barg (29 psig) ⁽¹⁾		3 barg (44 psig) ⁽¹⁾		4 barg (58 psig) ⁽¹⁾		4.7 barg (68 psig) ⁽¹⁾	
	Torque							
	N•m	lbf•in	N•m	lbf•in	N•m	lbf•in	N•m	lbf•in
1 (PDTO)	25.5	226	25.5	226	51.2	453	51.2	453
1 (PDTC)	25.5	226	36.2	320	51.2	453	72.4	641
2 (PDTO)	105	930	105	930	210	1860	210	1860
2 (PDTC)	105	930	175	1550	210	1860	320	2840
3 (PDTO)	327	2890	327	2890	631	5580	631	5580
3 (PDTC)	280	2480	557	4930	584	5170	930	8230

1. Do not interpolate between operating pressures. Consult your [Emerson sales office](#) for assistance.

Table 6. Dimensions

ACTUATOR SIZE	C		E		F		H		P		Y	
	mm	Inches	mm	Inches	mm	Inches	mm	Inches	mm	Inches	mm	Inches
1	245	9.65	267	10.51	29	1.14	103	4.06	107	4.21	71	2.80
2	350	13.78	424	16.69	49	1.93	187	7.36	170	6.69	84.5	3.33
3	496	19.53	592	23.31	64	2.52	254	10.0	185	7.28	92	3.62

Table 7. Actuator / Valve Body Mounting Dimensions

VALVE SHAFT DIAMETER		FIGURE 6 REFERENCE	T		U		W	
mm	Inches		mm	Inches	mm	Inches	mm	Inches
Style F Mounting: Control-Disk, Vee-Ball™, 8532, 8510B, 8560, and 8580 Eccentric Disk Valves								
12.7 - 15.9	1/2 - 5/8	A	117	4.62	---	---	14.2	0.56
19.1 - 25.4	3/4 - 1	B	152	6.00	32	1.25	14.2	0.56
31.8 - 38.1	1-1/4 - 1-1/2	B	235	9.25	46	1.81	17.5	0.69
44.5 - 50.8	1-3/4 - 2	B	273	10.75	51	2.00	20.6	0.81
Style G Mounting: 9500 Series Valves								
12.7	1/2	A	117	4.62	---	---	11.0	0.44
15.9 - 25.4	5/8 - 1	B	146	5.75	32	1.25	11.0	0.44
31.8 - 38.1	1-1/4 - 1-1/2	B	210	8.25	51	2.00	17.5	0.69

Table 8. Actuator / Valve Body Mounting Dimensions

VALVE SHAFT DIAMETER		V					
		Size 1		Size 2		Size 3	
mm	Inches	mm	Inches	mm	Inches	mm	Inches
12.7	1/2	135	5.3				
15.9	5/8	135	5.3	148.5	5.8		
19.1	3/4	158	6.2	171.5	6.8	179	7.0
25.4	1			171.5	6.8	179	7.0
31.8	1-1/4			169.5	6.7	177	7.0
38.1	1-1/2					177	7.0
44.5	1-3/4					316	12.4
50.8	2					316	12.4

Table 9. Actuator / Valve Body Mounting Dimensions

ACTUATOR SIZE	Hc		Jc		R
	mm	Inches	mm	Inches	NPT Connection Used
1	207	8.1	171	6.7	1/4 NPT
2	289	11.4	305	12.0	1/4 NPT
3	398	15.67	356	14.0	1/2 NPT

Table 10. NAMUR Instrument Mounting Dimensions

ACTUATOR SIZE	J	K	L	N
	mm	mm	mm	mm
1	80	30	30.4	35
2	130	30	48.34	55
3	130	30	65	75

Table 11. ISO 5211 Mounting Information

ACTUATOR SIZE	F SIZE	A	B	AA	BB
		mm	mm	mm	mm
1	F07	70	M8	16.5	See table 12
2	F10	102	M10	29.0	
3	F14	140	M16	49.0	

Table 12. ISO 5211 Square Insert Sizes Available

SQUARE SIZE	ACTUATOR SIZE		
	1	2	3
9	X		
11	X	X	
14	X	X	X
19		X	X
22		X	X
27			X
36			X

Figure 3. Dimensions (also see tables 6, 7, and 8)

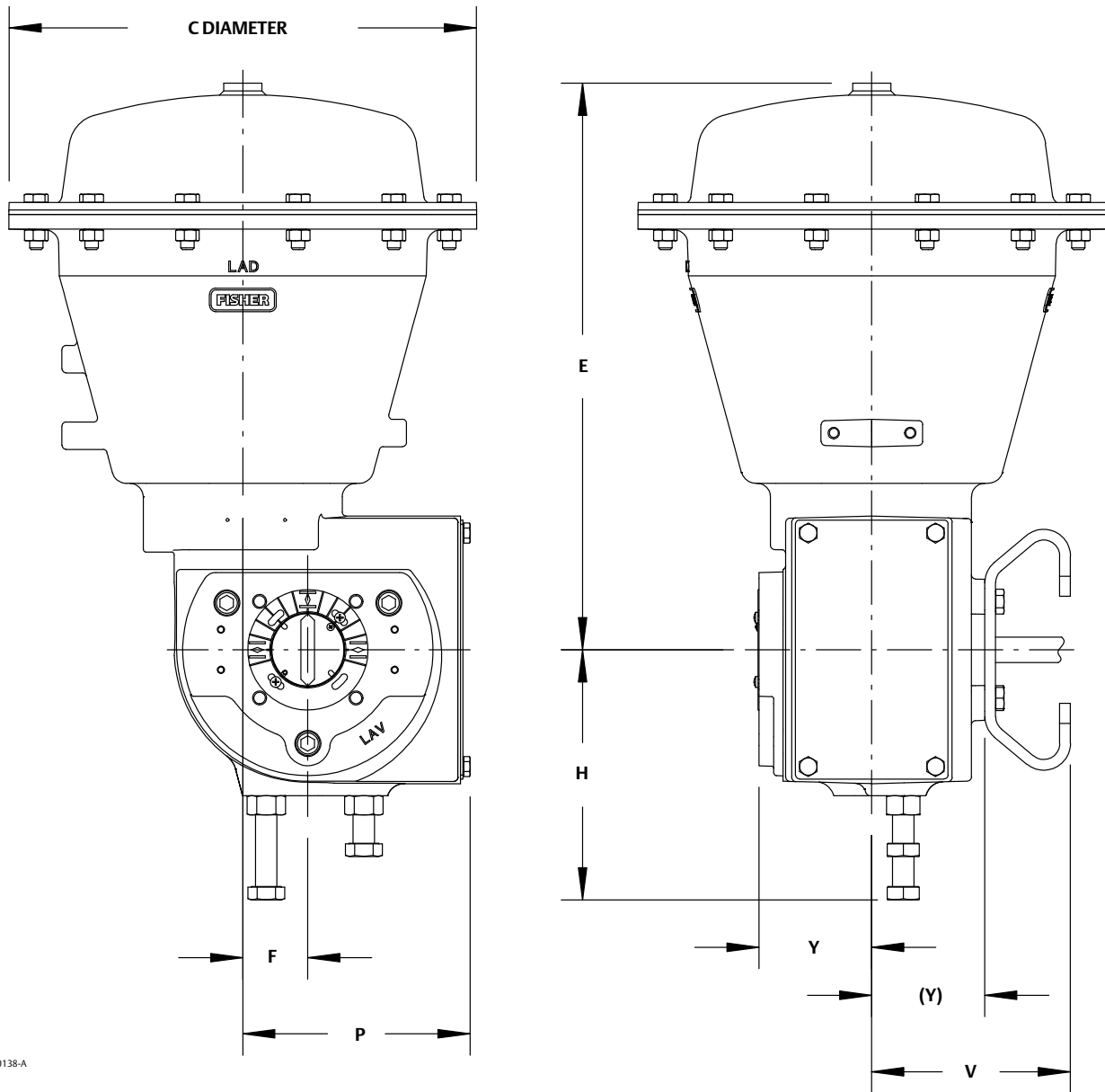

GG00138-A

Figure 4. Handwheel Dimensions (also see tables 6 and 9)

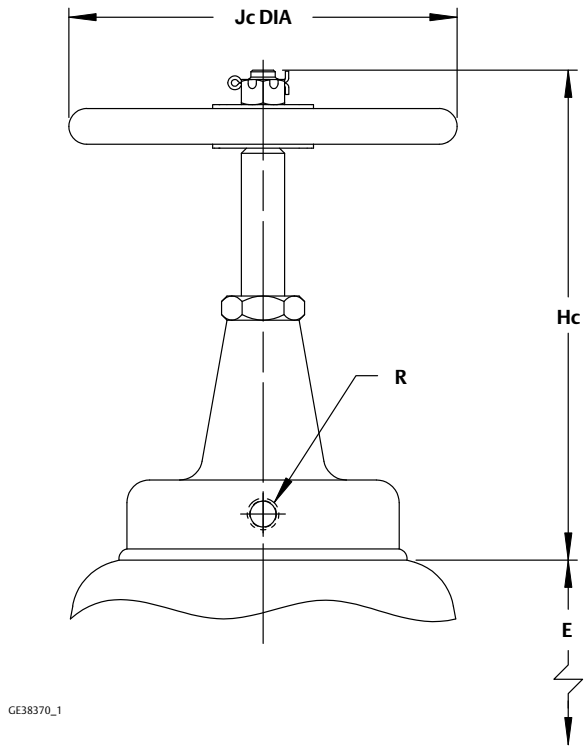

Figure 5. Mounting Yokes Dimensions (also see table 7)

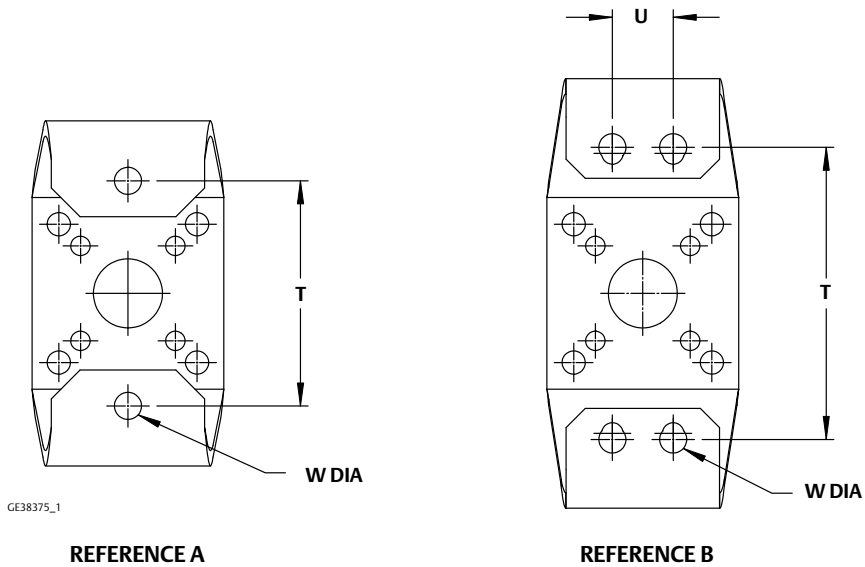
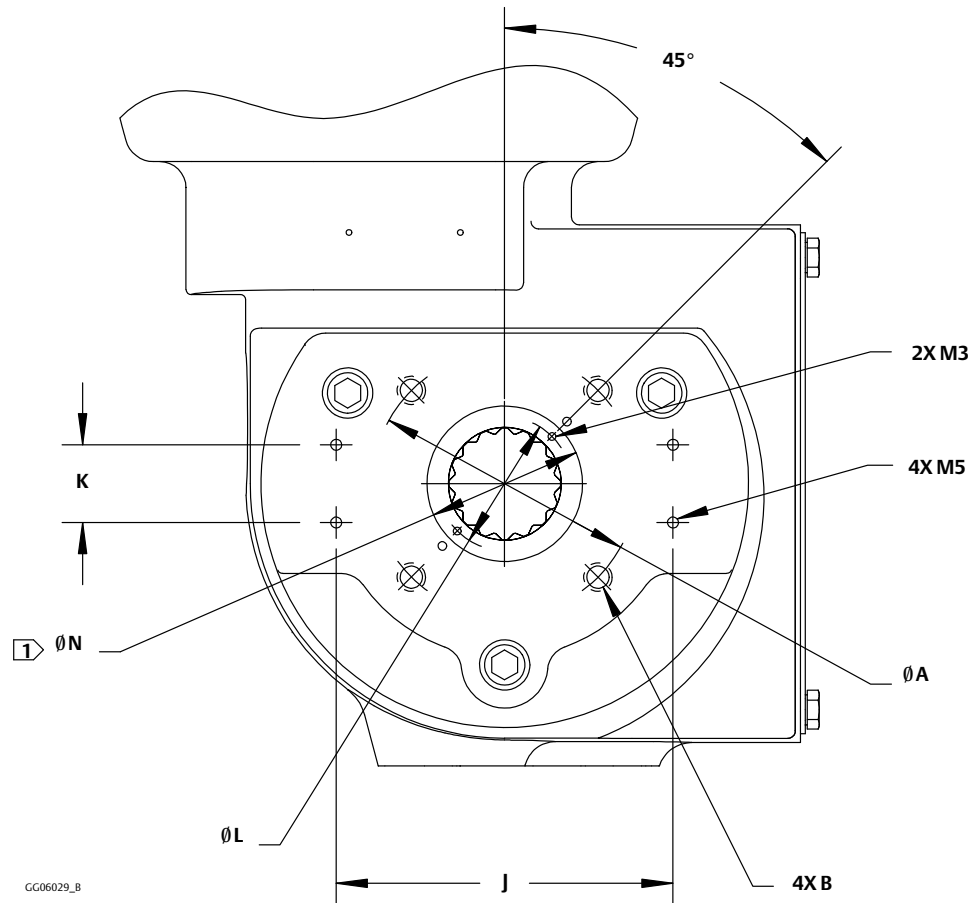

Figure 6. NAMUR Instrument Mounting Dimensions (also see tables 10 and 11)



1 N is the outside diameter of the lever hub.

Figure 7. ISO 5211 Square Lever Insert Dimensions (also see table 11)

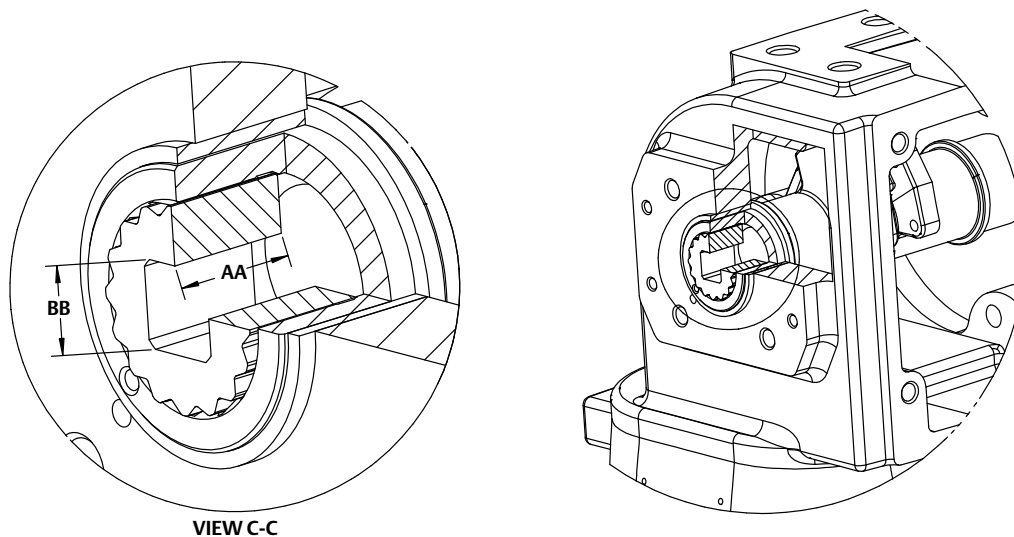

Figure 8. Fisher 2052 Actuator Mounting Styles (also see table 13)

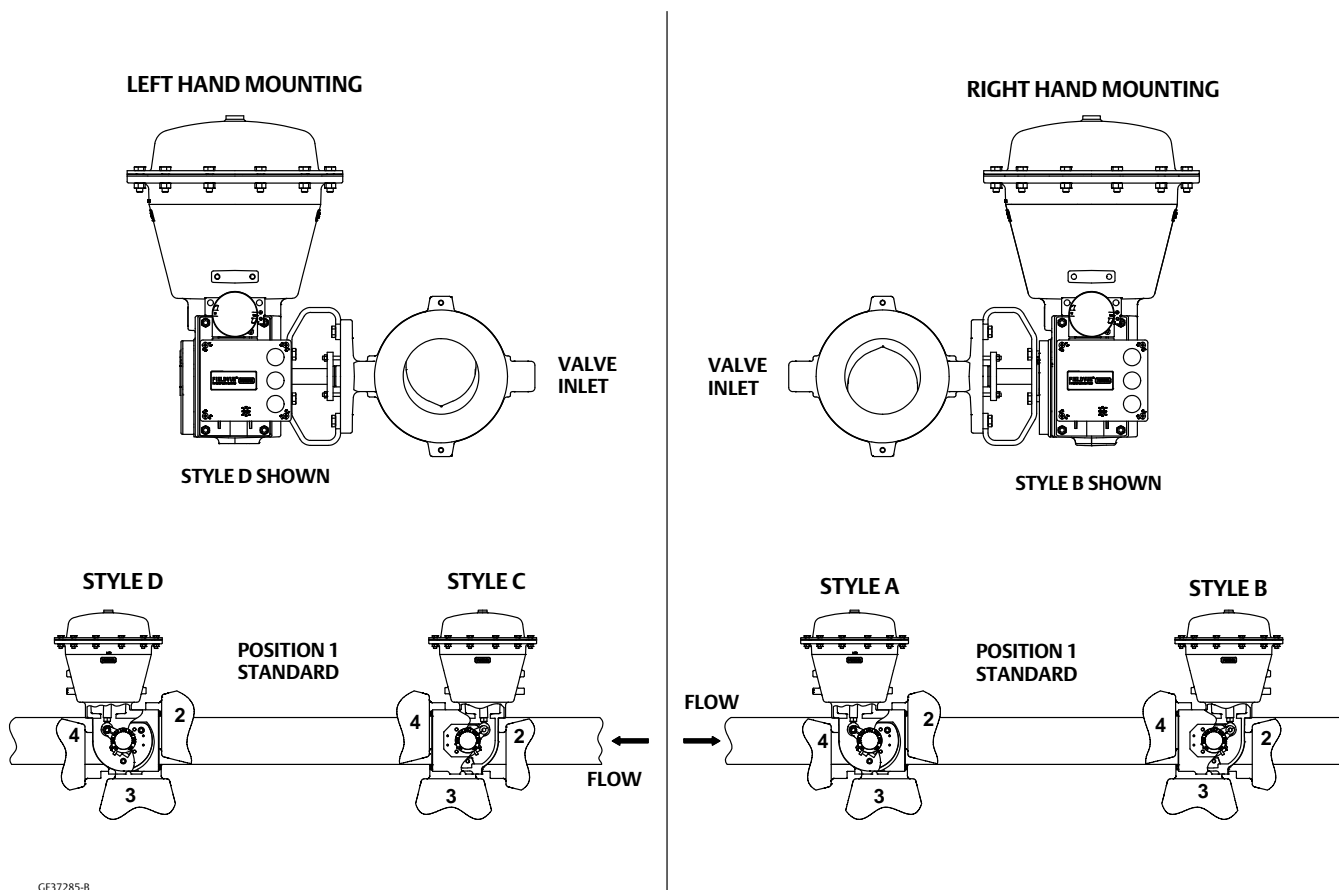

Table 13. Fisher 2052 Actuator Mounting Styles

MOUNTING (SEE FIGURE 8)	ACTION ⁽¹⁾	VALVE						
		Ball/Plug Rotation to Close	V150, V200, V300 Series	CV500 and V500	V250	Ball/Plug Rotation to Close	V250	8510, 8510B, 8532, 8560, 8580, 9500, Control-Disk
RIGHT-HAND	PDTC	CCW	A	A	A	CW	NA	B
	PDTO	CCW	B	B	B	CW	NA	A
LEFT-HAND	PDTC	CCW	D	D	NA	CW	C	C
	PDTO	CCW	C	C	NA	CW	D	D
LEFT-HAND (Optional)	PDTC	CW	C	NA	NA	NA	NA	NA
	PDTO	CW	D	NA	NA	NA	NA	NA

1. PDTC = Push Down To Close. PDTO = Push Down To Open.

Neither Emerson, Emerson Automation Solutions, nor any of their affiliated entities assumes responsibility for the selection, use or maintenance of any product. Responsibility for proper selection, use, and maintenance of any product remains solely with the purchaser and end user.

Fisher, Control-Disk, FIELDVUE, GO Switch, TopWorx, and Vee-Ball are marks owned by one of the companies in the Emerson Automation Solutions business unit of Emerson Electric Co. Emerson Automation Solutions, Emerson, and the Emerson logo are trademarks and service marks of Emerson Electric Co. All other marks are the property of their respective owners.

The contents of this publication are presented for informational purposes only, and while every effort has been made to ensure their accuracy, they are not to be construed as warranties or guarantees, express or implied, regarding the products or services described herein or their use or applicability. All sales are governed by our terms and conditions, which are available upon request. We reserve the right to modify or improve the designs or specifications of such products at any time without notice.

Emerson Automation Solutions
Marshalltown, Iowa 50158 USA
Sorocaba, 18087 Brazil
Cernay, 68700 France
Dubai, United Arab Emirates
Singapore 128461 Singapore

www.Fisher.com

