

Fisher™ 1B and 1BR Constant-Pressure Pump Governor Actuators

Figure 1. Fisher 1B Actuator on Direct-Acting easy-e™ Valve



W2232-1

Introduction

Scope of Manual

This instruction manual provides information on installation, adjustment, maintenance, and parts ordering for the Fisher 1B pump governor actuator. Refer to separate instruction manuals for information about the valve and other accessories used with these actuators.

Do not install, operate, or maintain a 1B pump governor actuator without being fully trained and qualified in valve, actuator, and accessory installation, operation, and maintenance. To avoid personal injury or property damage, it is important to carefully read, understand, and follow all the contents of this manual, including all safety cautions and

warnings. If you have any questions about these instructions, contact your [Emerson sales office](#) or Local Business Partner before proceeding.

Description

The 1B pump governor actuator (figure 1) is used to maintain a constant discharge pressure on steam driven turbine or reciprocating pumps and for pressure reducing or pressure relief applications. Typical pump governor applications include fire pumps, boiler feedwater pumps, and industrial or refining pumps where the discharge medium is oil, steam, air, or other noncorrosive fluid.

The 1BR pump governor actuator is combined with a push-down-to-open valve for service as a relief governor. A relief governor is used to divert excess pump discharge to the suction side of the pump.

Installation

⚠ WARNING

Always wear protective gloves, clothing, and eyewear when performing any installation operations to avoid personal injury.

Personal injury or equipment damage caused by sudden release of pressure may result if the valve assembly is installed where service conditions could exceed the limits given on the appropriate nameplates. To avoid such injury or damage, provide a relief valve for over-pressure protection as required by government or accepted industry codes and good engineering practices.

Check with your process or safety engineer for any additional measures that must be taken to protect against process media.

If installing into an existing application, also refer to the WARNING at the beginning of the Maintenance section in this instruction manual.

CAUTION

When ordered, the valve configuration and construction materials were selected to meet particular pressure, temperature, pressure drop, and controlled fluid conditions. Responsibility for the safety of process media and compatibility of valve materials with process media rests solely with the purchaser and end-user. Since some valve body/trim material combinations are limited in their pressure drop and temperature ranges, do not apply any other conditions to the valve without first contacting your Emerson sales office or Local Business Partner.

The 1B pump governor can be installed either above or below the line but if possible it should be installed above it.

CAUTION

Thoroughly clean and blow out all pipe scale and other foreign matter. It is recommended that a Fisher strainer be installed in the line ahead of the main valve to protect the governor while in service.

If continuous operation is desired during inspection or maintenance, install a conventional three-valve bypass around the governor.

Refer to figure 2.

1. Using good piping procedure install the governor with flow in the direction of the arrow cast on the valve body.
2. Run a 1/4 inch control line from the top of the governor to the side or top of the pump discharge line, about 10 feet from the pump. Install a pressure gauge and a large port needle valve in this line. Throttling this needle valve places a restriction in the control line to smooth out operation.

Figure 2. Fisher 1B Installation

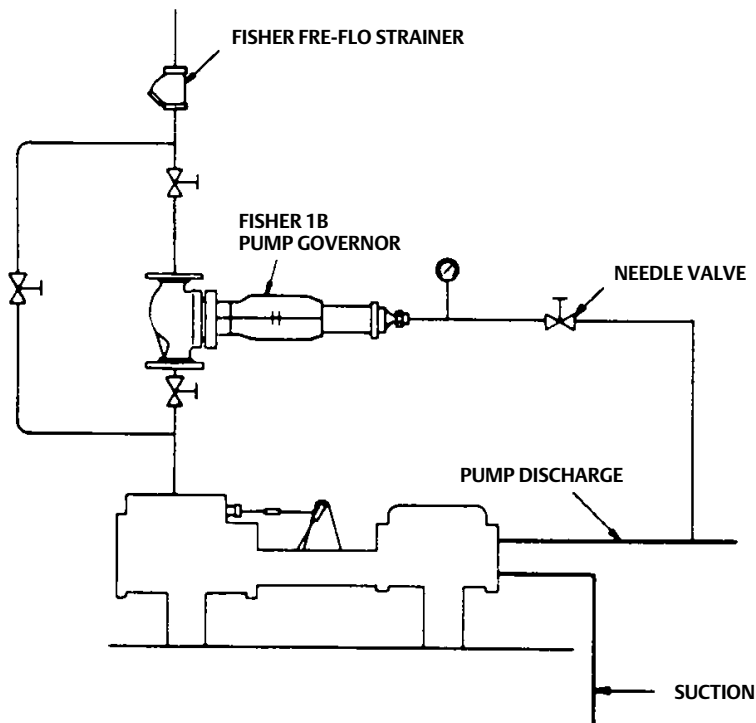

AC4650

Note

Before putting the governor into operation, be sure to remove the plastic shipping plug in the vent hole of the adaptor piece.

3. Open the gate valve on the downstream side and close the valve in the bypass line.
4. Slowly open the upstream gate valve.
5. Allow the governor sufficient time to assume normal operation before checking the controlled pressure. If the governor is not controlling at the set point needed, make the necessary changes as directed in the section entitled Adjustments.

Adjustments

The pump governor has been factory set for the operating conditions stated in the order. To change the pump discharge, use the adjusting screw (key 3). To increase the discharge pressure, turn the adjusting screw into the yoke.

Pressure pulsation in the discharge line can be minimized by slightly closing the needle valve in the control line. Never completely close the needle valve while the pump governor is in operation.

Maintenance

Actuator parts are subject to normal wear and must be inspected and replaced when necessary. The frequency of inspection and replacement depends on the severity of service conditions.

⚠ WARNING

Avoid personal injury or property damage from sudden release of process pressure or bursting of parts. Before performing any maintenance operations:

- Do not remove the actuator from the valve while the valve is still pressurized.
- Always wear protective gloves, clothing, and eyewear when performing any maintenance operations to avoid personal injury.
- Disconnect any operating lines providing air pressure, electric power, or a control signal to the actuator. Be sure the actuator cannot suddenly open or close the valve.
- Use bypass valves or completely shut off the process to isolate the valve from process pressure. Relieve process pressure from both sides of the valve. Drain the process media from both sides of the valve.
- Vent the power actuator loading pressure and relieve any actuator spring precompression.
- Use lock-out procedures to be sure that the above measures stay in effect while you work on the equipment.
- The valve packing box may contain process fluids that are pressurized, *even when the valve has been removed from the pipeline*. Process fluids may spray out under pressure when removing the packing hardware or packing rings, or when loosening the packing box pipe plug.
- Check with your process or safety engineer for any additional measures that must be taken to protect against process media.

When performing maintenance procedures, isolate the control valve from the process line pressure, release pressure from both sides of the valve body, and drain the process media from both sides of the valve. Use lock-out procedures to be sure that the above measures stay in effect while you are working on the actuator.

To Replace the Piston Cup:

1. Isolate the pump governor.
2. Remove the control line connection.
3. Unscrew the hex nuts (key 8).
4. Remove the cylinder cap (key 12).
5. Unscrew the cap screw (key 10) and remove the follower (key 6).
6. Remove the old piston cup (key 13) and install the new one.
7. Reassemble the pump governor in the following order: piston cup (key 13), follower (key 6), cap screw (key 10), cylinder cap (key 12), and hex nuts (key 8).

Parts Ordering

Each actuator has a serial number stamped on the nameplate. Always mention this number when corresponding with your [Emerson sales office](#) or Local Business Partner regarding technical information or replacement parts.

⚠ WARNING

Use only genuine Fisher replacement parts. Components that are not supplied by Emerson Automation Solutions should not, under any circumstances, be used in any Fisher valve, because they may void your warranty, might adversely affect the performance of the valve, and could cause personal injury and property damage.

Parts List

Note

Contact your Emerson sales office or Local Business Partner for Part Ordering information.

Key	Description
-----	-------------

1	Yoke, iron
2	Piston Rod Assembly, Steel Zn Pl
2A	Piston Rod
2B	Pin
2C	Piston
3	Adjusting Screw, Brass Chrome Pl

Key	Description
-----	-------------

4	Spring, Steel
6	Follower, Steel Zn Pl
7	Cylinder, Brass
8	Finished Hex Nut, Steel Zn Pl (6 req'd)
9	Stud Bolt, Steel, Zn Pl (6 req'd)
10	Cap Screw, Steel Zn Pl
11*	Gasket, Composition
12	Cylinder Cap, Iron
13*	Piston Cup, Nitrile
14	Adaptor Assembly
15	Hex Head Cap Screw, Steel Zn Pl (6 req'd)
16	Travel Stop, Steel Zn Pl (reverse-acting only)
17	Spring Seat, (2 req'd)
18	Finished Hex Nut, Steel Zn Pl
19	Finished Hex Jam Nut, Steel Zn Pl
20	Name Plate, SST
21	Drive Screw, SST (4 req'd)

*Recommended spare parts

Figure 3. Fisher 1B Assembly

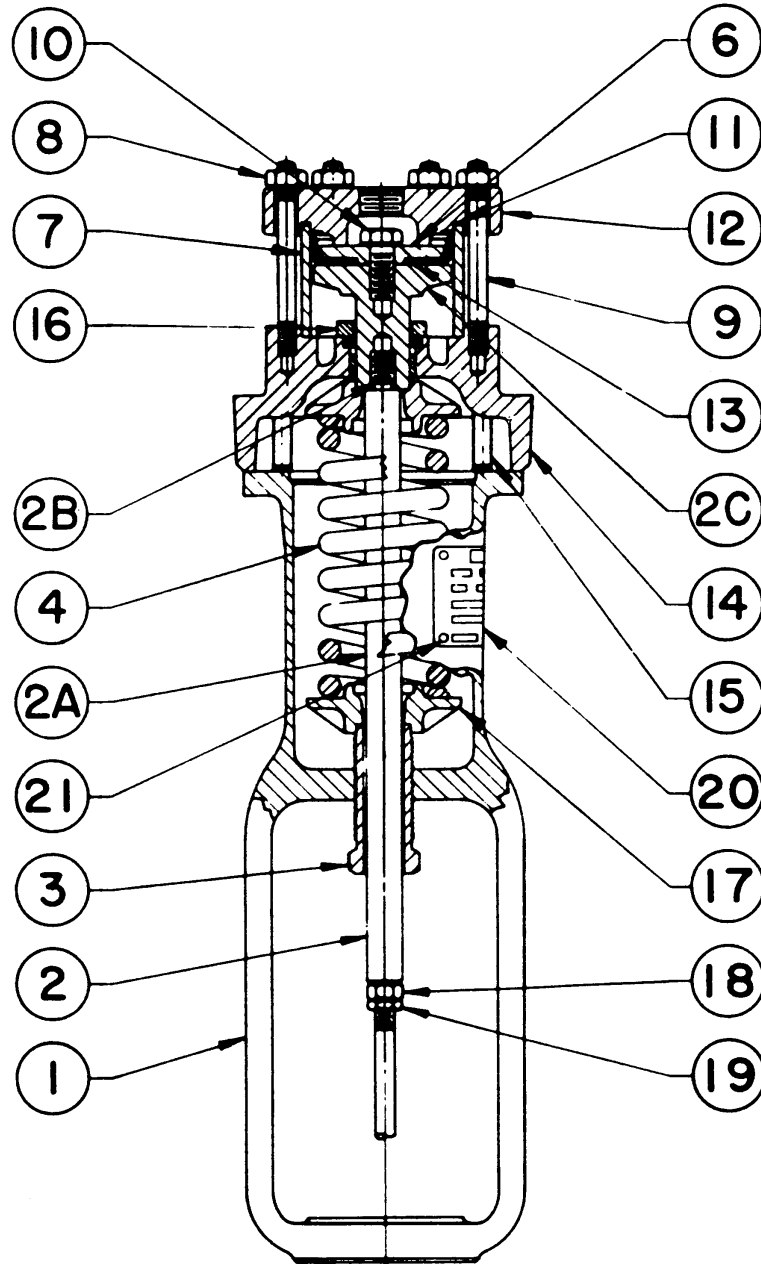

BNS768

Neither Emerson, Emerson Automation Solutions, nor any of their affiliated entities assumes responsibility for the selection, use or maintenance of any product. Responsibility for proper selection, use, and maintenance of any product remains solely with the purchaser and end user.

Fisher and easy-e are marks owned by one of the companies in the Emerson Automation Solutions business division of Emerson Electric Co. Emerson Automation Solutions, Emerson, and the Emerson logo are trademarks and service marks of Emerson Electric Co. All other marks are the property of their respective owners.

The contents of this publication are presented for informational purposes only, and while every effort has been made to ensure their accuracy, they are not to be construed as warranties or guarantees, express or implied, regarding the products or services described herein or their use or applicability. All sales are governed by our terms and conditions, which are available upon request. We reserve the right to modify or improve the designs or specifications of such products at any time without notice.

Emerson Automation Solutions
Marshalltown, Iowa 50158 USA
Sorocaba, 18087 Brazil
Cernay, 68700, France
Dubai, United Arab Emirates
Singapore 128461 Singapore

www.Fisher.com

