

# Type 1290 Vapor Recovery Regulator



Figure 1. Type 1290 Vapor Recovery Regulator

## Features

- **Quick-Change Trim Package** — Tested trim packages can be ordered and stocked ahead of time for fast replacement.
- **Easy In-Line Maintenance** — Top-entry design reduces maintenance time and manpower requirements; trim parts can be inspected, cleaned and replaced without removing the body from the line.
- **In-Service Travel Inspection** — Standard travel indicator assembly with protective cover permits periodic inspection of plug travel without removing regulator from service.
- **High Accuracy** — Total proportional band of 0.25 in. w.c. / 0.62 mbar or less at lower set pressures.
- **Proven Technology** — Time-proven regulator technology has been adapted to meet the specific requirements of vapor recovery (depadding) applications.

## Introduction

The Type 1290 vapor recovery regulator controls vessel blanketing gas pressure when the vessel is being filled with fluid or when ambient temperature causes the vapor gas to expand. The system monitors the increasing blanket pressure and throttles open to pass excess blanketing gas into a vapor disposal or reclamation system thus controlling the desired set pressure of the vessel.

### Note

**The vapor recovery regulator is not intended to be used as an ASME certified relief device for overpressure protection.**

The vapor recovery regulator responds to any changes in the blanket gas pressure and throttles open or closed to control the flow of the blanket gas out of the vessel. A vacuum source on the outlet of the regulator is usually necessary to ensure flow of low pressure blanket gas out of the vessel into a vapor disposal or reclamation system. The higher the vacuum pressure of the vacuum source, the higher the flow capacity of the vapor recovery regulator.

# Bulletin 74.2:1290

## Specifications

This section lists the specifications for the Type 1290 vapor recovery regulator. Specifications for a given regulator as it originally comes from the factory are stamped on the regulator nameplate located on the actuator, while the pilot control spring range appears on the pilot spring case nameplate.

### Body Size and End Connection Styles<sup>(1)</sup>

BODY SIZE, NPS / DN	TYPE EGR MAIN VALVE END CONNECTION STYLE	
	Cast Iron	WCC Steel or CF8M Stainless steel
1 or 2 / 25 or 50	NPT, CL125 FF or CL250 RF flanged	NPT, SWE, BWE, CL150 RF, CL300 RF, CL600 RF or PN 16/25/40 flanged
3, 4, or 6 / 80, 100 or 150	CL125 FF or CL250 RF flanged	BWE, CL150 RF, CL300 RF, CL600 RF or PN 16 flanged
8 x 6 or 12 x 6 / 200 x 150 or 300 x 150	----	BWE, CL150 RF, CL300 RF, CL600 RF or PN 25 flanged

### Construction Materials

See Table 1

### Maximum Inlet Pressures (Type EGR Main Valve)<sup>(2)</sup>

See Table 3

### Maximum Differential Pressure

35 psi / 2.4 bar

### Control Pressure Ranges (Type T208P or T208PL Pilot)<sup>(2)</sup>

See Table 2

### Type MR95H Supply Pressure Settings

PILOT TYPE	TYPE EGR MAIN VALVE WITH GREEN SPRING, NPS / DN		SPRING COLOR
	1, 2, 3 or 4 / 25, 50, 80 or 100	6 or 8 x 6 / 150 or 200 x 150	
T208PL	8 psig / 0.55 bar	13 psig / 0.90 bar	Black
T208P	8 psig / 0.55 bar	13 psig / 0.90 bar	Orange
	8 psig / 0.55 bar	13 psig / 0.90 bar	Red
	9 psig / 0.62 bar	14 psig / 0.97 bar	Unpainted
	10 psig / 0.69 bar	14 psig / 0.97 bar	Yellow
	11 psig / 0.76 bar	15 psig / 1.0 bar	Green
	14 psig / 0.97 bar	18 psig / 1.2 bar	Light blue
	15 psig / 1.0 bar	20 psig / 1.4 bar	Black

### Type T208P or T208PL Pilot Orifice Diameter

3/8 in. / 9.5 mm

### Flow Capacities

See Table 5

### Flow Coefficients

See Table 6

### Control Line Connection

1/2 NPT

### Exhaust Line Connection

3/4 NPT

### Supply Pressure and Spring Case Connections

1/4 NPT

### Orifice Diameters and Travels

BODY SIZE		PORT DIAMETER		TRAVEL	
NPS	DN	In.	mm	In.	mm
1	25	1-5/16	33	3/4	19
2	50	2-3/8	60	1-1/8	29
3	80	3-3/8	86	1-1/2	38
4	100	4-3/8	111	2	51
6	150	7-3/16	183	2	51
8 x 6	200 x 150	7-3/16	183	2	51
12 x 6	300 x 150	7-3/16	183	2	51

### Main Valve Material Temperature Capabilities<sup>(2)</sup>

#### Nitrile (NBR):

-20 to 180°F / -29 to 82°C

#### Fluorocarbon (FKM):

For In. w.c. Setpoints: 40 to 300°F / 4 to 149°C

For psig Setpoints: 0 to 300°F / -18 to 149°C

#### Ethylene propylene (EPDM):

-20 to 275°F / -29 to 135°C

#### Perfluoroelastomer (FFKM):

-20 to 300°F / -29 to 149°C

### Pilot Temperature Capabilities

See Table 4

### Approximate Weights

**NPS 1 / DN 25:** 85 lbs / 39 kg

**NPS 2 / DN 50:** 100 lbs / 45 kg

**NPS 3 / DN 80:** 145 lbs / 66 kg

**NPS 4 / DN 100:** 195 lbs / 88 kg

**NPS 6 / DN 150:** 380 lbs / 172 kg

**NPS 8 x 6 / DN 200 x 150:** 740 lbs / 336 kg

**NPS 12 x 6 / DN 300 x 150:** 1265 lbs / 574 kg

1. End connections for other than U.S. standards can usually be provided. Consult your local Sales Office.

2. The pressure/temperature limits in this Bulletin and any applicable standard or code limitation should not be exceeded.

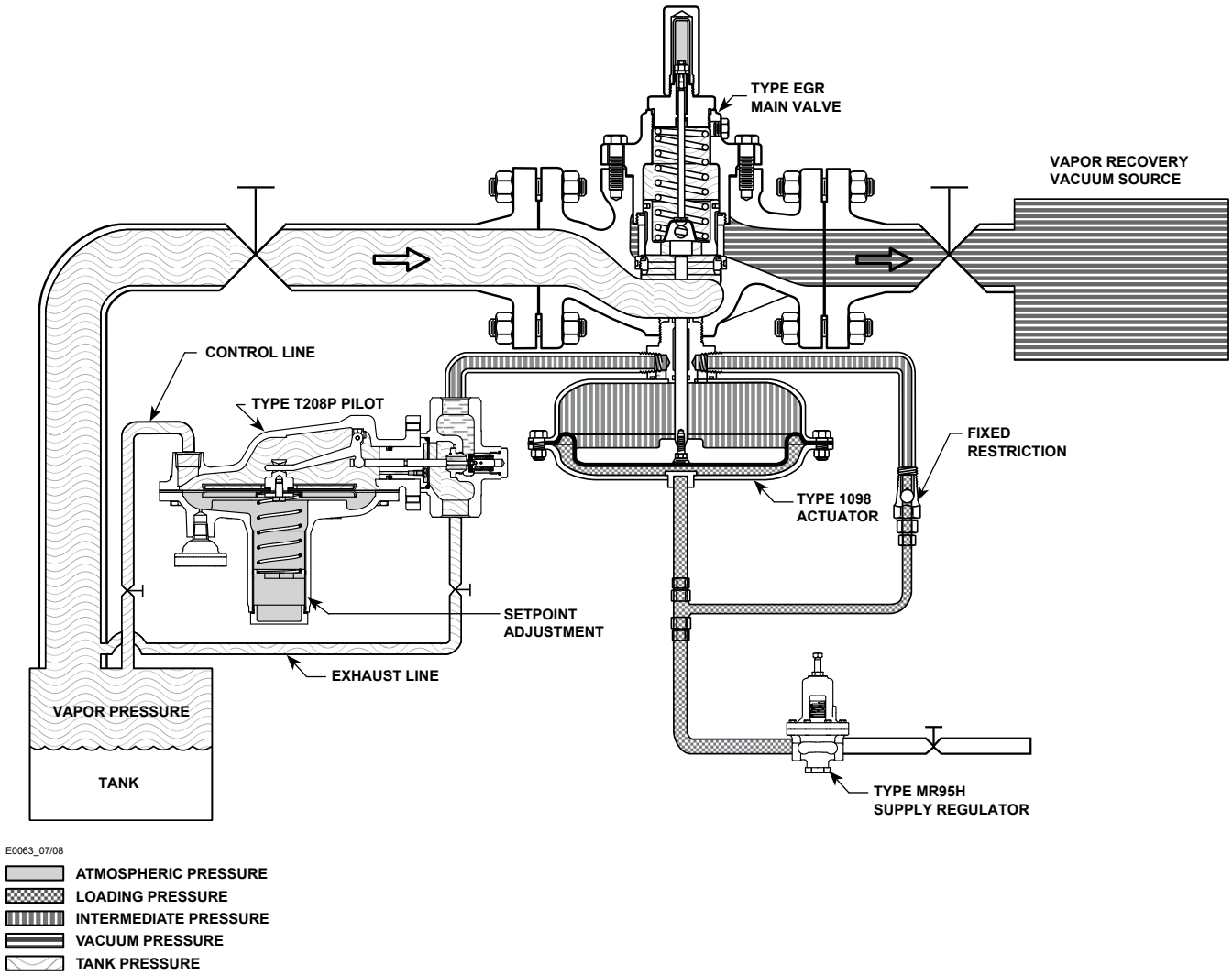

Figure 2. Operational Schematic

Table 1. Construction Materials (Refer to Table 9 for Reference on Material Compatibility)<sup>(1)</sup>

MAIN VALVE				SIZE 40 ACTUATOR	PILOT	SUPPLY REGULATOR	DIAPHRAGM	O-RING AND SEAL
Body and Body Flange	Plug and Seat Ring	Spring	Cage					
Cast iron	416 Stainless steel	Steel	Cast iron	Steel	Cast iron	Cast iron	Nitrile (NBR), Fluorocarbon (FKM), Fluorinated Ethylene Propylene (FEP) or Ethylenepropylene (EPDM)	Nitrile (NBR), Fluorocarbon (FKM), Ethylenepropylene (EPDM) or Perfluoroelastomer (FFKM)
WCC Steel	416 Stainless steel	Steel	Steel	Steel	WCC Steel	WCC Steel		
CF8M Stainless steel	316 Stainless steel	Inconel® X-750	316 Stainless steel Whisper Trim™ Cage	Stainless steel	CF3M Stainless steel	CF8M Stainless steel		

1. Special construction materials are offered for your system compatibility. Contact your local Sales Office for additional information.

## Principle of Operation

The Type 1290 vapor recovery regulator serves as a vessel vapor recovery system. The Type 1290 regulator controls vessel blanketing gas pressure when the vessel is being filled with fluid or when ambient temperature causes the vapor gas to expand.

The system monitors the increasing blanket pressure and throttles open to pass excess blanketing gas into a vapor recovery system thus controlling the desired set pressure of the vessel.

Inconel® is a mark owned by Special Metals Corporation.

# Bulletin 74.2:1290

**Table 2. Control Pressure Ranges**

PILOT TYPE	CONTROL PRESSURE RANGES <sup>(1)</sup>	SPRING COLOR	SPRING PART NUMBER	BUILDUP TO WIDE-OPEN (TYPE EGR MAIN VALVE)	SPRING WIRE DIAMETER		SPRING FREE LENGTH	
					In.	mm	In.	mm
T208PL	0.5 to 1.5 in. w.c. / 1 to 4 mbar <sup>(2)</sup>	Black	1B413627222	0.25 in. w.c. / 0.60 mbar	0.075	1.90	2.19	56.0
T208P	1 to 2.5 in. w.c. / 2 to 6 mbar <sup>(2)(3)</sup>	Orange	1B558527052	0.25 in. w.c. / 0.60 mbar	0.072	1.83	3.25	83
	2 to 7 in. w.c. / 5 to 17 mbar <sup>(2)(4)</sup>	Red	1B653827052	0.25 in. w.c. / 0.60 mbar	0.085	2.20	3.63	92.0
	4 to 14 in. w.c. / 10 to 35 mbar	Unpainted	1B653927022	0.25 in. w.c. / 0.60 mbar	0.100	2.70	3.75	95.0
	0.5 to 1.2 psig / 35 to 83 mbar	Yellow	1B537027052	1.4 in. w.c. / 3 mbar	0.114	2.90	4.31	109
	1.0 to 2.5 psig / 0.07 to 0.17 bar	Green	1B537127022	2.8 in. w.c. / 7 mbar	0.156	4.00	4.06	103
	2.5 to 4.5 psig / 0.17 to 0.31 bar	Light blue	1B537227022	4.2 in. w.c. / 10 mbar	0.187	4.80	3.94	100
	4.5 to 7 psig / 0.31 to 0.48 bar	Black	1B537327052	5.5 in. w.c. / 14 mbar	0.218	5.40	3.98	101

1. Spring ranges based on pilot being installed with the spring case pointed down.  
 2. Do not use Fluorocarbon (FKM) diaphragm with this spring at diaphragm temperatures lower than 60°F / 16°C.  
 3. When using a Fluorocarbon (FKM) diaphragm, the minimum outlet pressure is 2 in. w.c. / 5 mbar.  
 4. When using a Fluorocarbon (FKM) diaphragm, the minimum outlet pressure is 2.5 in. w.c. / 6 mbar.

**Table 3. Maximum Main Valve Inlet Pressures**

PILOT TYPE	MAXIMUM INLET PRESSURE, psig / bar					SPRING COLOR
	Type EGR Main Valve with Green Spring					
	NPS 1 / DN 25	NPS 2 / DN 50	NPS 3 / DN 80	NPS 4 / DN 100	NPS 6, 8 x 6 or 12 x 6 / DN 150, 200 x 150 or 300 x 150	
T208PL	5.5 / 0.38	5 / 0.35	4 / 0.28	3 / 0.21	3.5 / 0.24	Black
T208P	5.5 / 0.38	5 / 0.35	4 / 0.28	3 / 0.21	3.5 / 0.24	Orange
	5.5 / 0.38	5 / 0.35	4 / 0.28	3 / 0.21	3.5 / 0.24	Red
	6.5 / 0.45	6 / 0.41	5 / 0.35	4 / 0.28	4.5 / 0.31	Unpainted
	7.5 / 0.52	7 / 0.48	6 / 0.41	5 / 0.35	4.5 / 0.31	Yellow
	8.5 / 0.59	8 / 0.55	7 / 0.48	6 / 0.41	5.5 / 0.38	Green
	11.5 / 0.79 <sup>(1)</sup>	11 / 0.76 <sup>(1)</sup>	10 / 0.69	9 / 0.62	8.5 / 0.59	Light Blue
	12.5 / 0.86 <sup>(1)</sup>	12 / 0.83 <sup>(1)</sup>	11 / 0.76 <sup>(1)</sup>	10 / 0.69	10.5 / 0.72 <sup>(1)</sup>	Black

1. For Fluorinated Ethylene Propylene (FEP) Pilot Diaphragm, the maximum inlet pressure is 10 psig / 0.69 bar.

**Table 4. Diaphragm Material Selection Information**

TRIM OPTION CODE	DIAPHRAGM MATERIAL	DISK AND O-RING MATERIAL	OPERATING TEMPERATURE RANGE
Standard	Nitrile (NBR)	Nitrile (NBR)	-40 to 180°F / -40 to 82°C
VV	Fluorocarbon (FKM)	Fluorocarbon (FKM)	40 to 300°F / 4 to 149°C
TN	Fluorinated Ethylene Propylene (FEP)	Nitrile (NBR)	-20 to 180°F / -29 to 82°C
TV	Fluorinated Ethylene Propylene (FEP)	Fluorocarbon (FKM)	40 to 180°F / 4 to 82°C
TK	Fluorinated Ethylene Propylene (FEP)	Perfluoroelastomer (FFKM)	0 to 180°F / -18 to 82°C
TE	Fluorinated Ethylene Propylene (FEP)	Ethylene Propylene Diene (EPDM)	-20 to 180°F / -29 to 82°C

**Table 5. Flow Capacities for Type 1290 Vapor Recovery Regulators**

PILOT TYPE	PILOT SPRING COLOR	CONTROL PRESSURE	BUILDUP OVER CONTROL PRESSURE TO WIDE-OPEN <sup>(1)</sup>	DOWNSTREAM VACUUM PRESSURE	CAPACITIES IN SCFH / Nm <sup>3</sup> /h OF 0.97 SPECIFIC GRAVITY NITROGEN									
					NPS 1 / DN 25 Body		NPS 2 / DN 50 Body		NPS 3 / DN 80 Body		NPS 4 / DN 100 Body		NPS 6 / DN 150 Body	
T208PL	Black	0.5 in. w.c. / 1 mbar	0.25 in. w.c. / 0.60 mbar	0 psig / 0 bar 2.5 psig / 0.17 bar 5 psig / 0.34 bar	600	16.1	2300	61.6	4900	131	7600	204	14,600	391
					5600	150	19,900	533	43,100	1155	66,900	1793	124,500	3337
T208P	Orange	1 in. w.c. / 2 mbar	0.25 in. w.c. / 0.60 mbar	0 psig / 0 bar 2.5 psig / 0.17 bar 5 psig / 0.34 bar	700	18.8	2700	72.4	5900	158	9200	247	17,700	474
					5700	153	10,000	268	43,200	1158	67,000	1796	126,700	3396
	Unpainted	2 in. w.c. / 5 mbar	0.25 in. w.c. / 0.60 mbar	0 psig / 0 bar 2.5 psig / 0.17 bar 5 psig / 0.34 bar	1100	29.5	3900	105	8400	225	13,000	348	25,000	670
					5800	155	20,200	541	43,500	1166	67,600	1812	127,700	3422
	Yellow	4 in. w.c. / 10 mbar	0.25 in. w.c. / 0.60 mbar	0 psig / 0 bar 2.5 psig / 0.17 bar 5 psig / 0.34 bar	1500	40.2	5300	142	11,500	308	17,800	477	34,200	917
					5800	155	20,500	549	44,100	1182	68,500	1836	129,400	3468
	Light blue	8 in. w.c. / 20 mbar	0.25 in. w.c. / 0.60 mbar	0 psig / 0 bar 2.5 psig / 0.17 bar 5 psig / 0.34 bar	7500	201	26,300	705	56,600	1517	88,100	2361	162,200	4347
					2100	56.3	7400	198	16,000	429	24,800	665	47,600	1276
	Black	14 in. w.c. / 35 mbar	0.25 in. w.c. / 0.60 mbar	0 psig / 0 bar 2.5 psig / 0.17 bar 5 psig / 0.34 bar	6000	161	21,000	563	45,300	1214	70,400	1887	132,800	3559
					7600	204	26,800	718	57,700	1546	89,800	2407	166,200	4454
	Black	1 psig / 0.07 bar	0.05 psig / 3 mbar	0 psig / 0 bar 2.5 psig / 0.17 bar 5 psig / 0.34 bar	2900	77.7	10,100	271	21,800	584	33,800	906	64,900	1739
					6300	169	22,000	590	47,400	1270	73,600	1972	138,700	3717
Black	3 psig / 0.21 bar	0.15 psig / 10 mbar	0 psig / 0 bar 2.5 psig / 0.17 bar 5 psig / 0.34 bar	7900	212	27,800	745	59,800	1603	93,100	2495	172,400	4620	
				4000	107	14,100	378	30,500	817	47,200	1265	90,300	2420	
Black	5 psig / 0.34 bar	0.15 psig / 10 mbar	0 psig / 0 bar 2.5 psig / 0.17 bar 5 psig / 0.34 bar	6800	182	23,900	641	51,400	1378	79,900	2141	150,100	4023	
				8100	217	28,700	769	61,800	1656	96,200	2578	177,200	4749	
Black	7 psig / 0.48 bar	0.20 psig / 14 mbar	0 psig / 0 bar 2.5 psig / 0.17 bar 5 psig / 0.34 bar	7000	188	24,700	662	53,200	1426	82,500	2211	155,800	4175	
				8700	233	30,600	820	66,000	1769	102,700	2752	190,700	5111	
Black			0 psig / 0 bar 2.5 psig / 0.17 bar 5 psig / 0.34 bar	9600	257	34,100	914	73,400	1967	114,600	3071	209,100	5604	
				9100	244	31,900	855	68,600	1838	106,700	2860	199,500	5347	
Black			0 psig / 0 bar 2.5 psig / 0.17 bar 5 psig / 0.34 bar	10,200	273	36,300	973	78,100	2093	121,600	3259	224,000	6003	
				11,000	295	39,000	1045	83,900	2249	131,000	3511	327,400	8774	
Black			0 psig / 0 bar 2.5 psig / 0.17 bar 5 psig / 0.34 bar	10,800	289	38,200	1024	82,200	2203	127,900	3428	237,100	6354	
				11,700	314	41,600	1115	89,500	2399	139,700	3744	255,300	6842	
Black			0 psig / 0 bar 2.5 psig / 0.17 bar 5 psig / 0.34 bar	12,300	330	43,800	1174	94,200	2525	147,300	3948	265,100	7105	

1. Increased capacity is available at higher buildups.

Table 6. Flow Coefficients

BODY SIZE, NPS / DN	PIPING STYLE											
	Line Size Equals Body Size Piping											
	Linear Cage						Drilled Hole Whisper Trim™ Cage					
	C <sub>g</sub>		C <sub>v</sub>		C <sub>i</sub>	K <sub>m</sub>	C <sub>g</sub>		C <sub>v</sub>		C <sub>i</sub>	K <sub>m</sub>
Regulating	Wide-Open	Regulating	Wide-Open	Regulating			Wide-Open	Regulating	Wide-Open			
1 / 25	600	632	16.8	17.7	35.7	0.70	576	607	16.7	17.6	34.5	0.80
2 / 50	2280	2400	63.3	66.7	36.0		1970	2080	54.7	57.8	36.0	
3 / 80	4630	4880	132	139	35.1		3760	3960	107	113	35.0	
4 / 100	7320	7710	202	213	36.2		6280	6610	180	190	34.8	
6 / 150	12,900	13,600	397	418	32.5		9450	9950	295	310	32.0	
8 x 6 / 200 x 150	18,480	19,450	578	608	32.0		10,660	11,220	305	321	35.0	
12 x 6 / 300 x 150	21,180	22,290	662	697	32.0		11,050	11,630	316	332	35.0	

BODY SIZE, NPS / DN	PIPING STYLE											
	2:1 Line Size to Body Size Piping											
	Standard Linear Cage						Drilled Hole Whisper Trim Cage					
	C <sub>g</sub>		C <sub>v</sub>		C <sub>i</sub>	K <sub>m</sub>	C <sub>g</sub>		C <sub>v</sub>		C <sub>i</sub>	K <sub>m</sub>
Regulating	Wide-Open	Regulating	Wide-Open	Regulating			Wide-Open	Regulating	Wide-Open			
1 / 25	568	598	17.2	18.1	33.0	0.70	529	557	15.6	16.4	34.0	0.80
2 / 50	2050	2160	59.6	62.8	34.4		1830	1930	52.3	55.1	35.1	
3 / 80	4410	4650	128	135	34.4		3630	3830	106	110	34.2	
4 / 100	6940	7310	198	209	35.0		6020	6340	171	180	35.2	
6 / 150	12,100	12,800	381	404	31.7		9240	9730	291	306	31.7	
8 x 6 / 200 x 150	17,370	18,280	543	571	32.0		10,020	10,550	286	301	35.0	
12 x 6 / 300 x 150	19,900	20,950	622	655	32.0		10,380	10,930	297	312	35.0	

Table 7. Flow Rate Conversions (Gas Flow Required to Displace Blanketing Gas with Pump-in of Liquid)

MULTIPLY MAXIMUM PUMP RATE IN	BY	TO OBTAIN
U.S. GPM	8.021	SCFH air required <sup>(2)</sup>
U.S. GPH	0.1337	
Barrels/hour	5.615	
Barrels/day	0.2340	

1. For liquids with a flash point below 100°F / 38°C or normal boiling point below 300°F / 149°C, multiply the above calculated outbreathing requirement by 2.0.  
 2. To convert to Nm<sup>3</sup>/h, multiply SCFH by 0.0268.

**Note**

**The Type 1290 Vapor Recovery Regulator is not intended to be used as an ASME certified relief device for overpressure protection. It is to be used as part of the gas blanketing system to control the outflow of blanketing gas under normal conditions and to collect vessel vapors for the vapor recovery system. You should provide alternate methods of emergency overpressure protection.**

The Type 1290 vapor recovery regulator responds to any changes in the blanket gas pressure and throttles open or closed to control the flow of the blanket gas out of the vessel. A vacuum source on the outlet of the regulator is usually necessary to ensure flow of low pressure blanket gas out of the vessel into a vapor recovery system. The higher the vacuum pressure of the vacuum source, the higher the flow capacity of the vapor recovery regulator.

The pressure of the blanket gas registers under the diaphragm of the pilot. A Type MR95H regulator provides a constant loading pressure source to the Type 1098

actuator. When the pilot is closed, the loading pressure fills both sides of the Type 1098 actuator through a fixed restriction.

The Type EGR main valve spring keeps the main valve plug tightly shut off. When the vessel blanket gas pressure reaches the setting of the pilot spring, the pilot diaphragm moves, opening the pilot valve disk and exhausting some of the Type 1098's actuator loading pressure through the pilot orifice. This typically happens when the vessel is being filled with liquid.

The small fixed restriction maintains a higher loading pressure on the bottom of the Type 1098 actuator. The pressure differential across the main valve diaphragm moves the diaphragm upward causing the main valve to open which allows the blanket gas to flow out to the vapor recovery system vacuum source, hence controlling the vessel blanket pressure.

When the vessel blanket gas pressure begins to stabilize, the pilot spring throttles the pilot disk closed. This allows the loading pressure source to fill both sides of the Type 1098 actuator through the fixed restriction. This equalizes the pressure acting on the diaphragm, thus allowing the main valve spring to close the main valve plug.

# Bulletin 74.2:1290

**Table 8. Gas Flow Required for Thermal Heating (Outbreathing) per API 2000 (Interpolate for intermediate sizes)**

VESSEL CAPACITY			SCFH / Nm <sup>3</sup> /h AIR FLOW RATE REQUIRED	
Barrels	Gallons	Liters	Flash Point is Equal to or Above 100°F / 38°C or Normal Boiling Point is Equal to or Above 300°F / 149°C	Flash Point is Below 100°F / 38°C or Normal Boiling Point is Below 300°F / 149°C
60	2500	9500	40 / 1.07	60 / 1.61
100	4200	16,000	60 / 1.61	100 / 2.68
500	21,000	79,500	300 / 8.04	500 / 13.4
1000	42,000	159,000	600 / 16.1	1000 / 26.8
2000	84,000	318,000	1200 / 32.2	2000 / 53.6
3000	126,000	477,000	1800 / 48.2	3000 / 80.4
4000	168,000	636,000	2400 / 64.3	4000 / 107
5000	210,000	795,000	3000 / 80.4	5000 / 134
10,000	420,000	1,590,000	6000 / 161	10,000 / 268
15,000	630,000	2,385,000	9000 / 241	15,000 / 402
20,000	840,000	3,180,000	12,000 / 322	20,000 / 536
25,000	1,050,000	3,975,000	15,000 / 402	24,000 / 643
30,000	1,260,000	4,769,000	17,000 / 456	28,000 / 750
35,000	1,470,000	5,564,000	19,000 / 509	31,000 / 831
40,000	1,680,000	6,359,000	21,000 / 563	34,000 / 911
45,000	1,890,000	7,154,000	23,000 / 616	37,000 / 992
50,000	2,100,000	7,949,000	24,000 / 643	40,000 / 1072
60,000	2,520,000	9,539,000	27,000 / 724	44,000 / 1179
70,000	2,940,000	11,298,000	29,000 / 777	48,000 / 1286
80,000	3,360,000	12,718,000	31,000 / 831	52,000 / 1394
90,000	3,780,000	14,308,000	34,000 / 911	56,000 / 1501
100,000	4,200,000	15,897,000	36,000 / 965	60,000 / 1608
120,000	5,040,000	19,077,000	41,000 / 1099	68,000 / 1822
140,000	5,880,000	22,256,000	45,000 / 1206	75,000 / 2010
160,000	6,720,000	25,436,000	50,000 / 1340	82,000 / 2198
180,000	7,560,000	28,615,000	54,000 / 1447	90,000 / 2412

## Sizing Blanketing Systems

When sizing a gas vapor recovery regulator system, you must consider the volume of blanketing gas that must be displaced from the vessel when either filling the vessel with liquid (pump-in) or the expansion of vapors inside the vessel during atmospheric thermal heating.

Using the established procedures from American Petroleum Institute Standard 2000 (API 2000), determine the flow rate for outbreathing.

1. Determine the flow rate of blanketing gas displaced when liquid is being pumped into the vessel (see Table 7).
2. Determine the gas flow rate due to outbreathing caused by atmospheric thermal heating (see Table 8).
3. Add the requirements of 1 and 2 and select a vapor recovery regulator size based on total capacity required from Table 5.

### Sample Sizing Problem for Vapor Recovery Applications:

Vessel Capacity . . . . . 1000 barrels  
 Pump in Capacity . . . . . 20 GPM / 75.7 lpm  
 Inlet Pressure Source . . . . . 60 psig / 4.1 bar nitrogen  
 Desired Blanket Setpoint . . . . . .0.5 in. w.c. / 1 mbar  
 Desired Vapor Recovery Setpoint . . . . . 2 in. w.c. / 5 mbar  
 Vapor Recovery Vacuum Source . . . . . 5 in. Hg / 169 mbar  
 Fluid . . . . . Hexane  
 Boiling Point . . . . . 155°F / 68°C

1. From Table 7 the desired air flow rate due to pump in equals 20 GPM x 8.021 x 2 = 320 SCFH / 8.58 Nm<sup>3</sup>/h air.

2. From Table 8 the desired air flow rate = 1000 SCFH / 26.8 Nm<sup>3</sup>/h air due to thermal heating.
3. Total required flow rate = 1000 SCFH air + 320 SCFH = 1320 SCFH / 35.4 Nm<sup>3</sup>/h air. This converts to nitrogen requirements of 1340 SCFH / 35.9 Nm<sup>3</sup>/h.

## Capacity Information

Table 5 gives typical nitrogen regulating capacities at selected inlet pressures and outlet pressure settings. Flows are in SCFH (at 60°F and 14.7 psia) and Nm<sup>3</sup>/h (at 0°C and 1.01325 bar) of 0.97 specific gravity nitrogen. For gases of other specific gravities, multiply the given capacity of nitrogen by 0.985 and divide by the square root of the appropriate specific gravity of the gas required. To determine regulating capacities at pressure settings not given or to determine wide-open flow capacities, use the following formula:

$$Q = \sqrt{\frac{520}{GT}} C_g P_1 \sin \left[ \frac{3417}{C_1} \sqrt{\frac{\Delta P}{P_1}} \right] \text{ Deg}$$

where:

- C<sub>g</sub> = gas sizing coefficient from Table 6
- C<sub>1</sub> = C<sub>g</sub>/C<sub>v</sub> or 35 from Table 6
- G = gas specific gravity (air = 1.0)
- P<sub>1</sub> = absolute inlet pressure, psia (add 14.7 psi to gauge inlet pressure to obtain absolute inlet pressure)
- Q = flow rate, SCFH
- T = absolute temperature in °R of gas at inlet (°F + 460)

Table 9. Materials Compatibility

CORROSION INFORMATION															
Fluid	Material							Fluid	Material						
	Carbon steel	Cast or Ductile Iron	302 or 304 Stainless Steel	CF8M or 316 Stainless steel	416 Stainless steel	Monel <sup>®</sup> (1)	Hastelloy <sup>®</sup> C <sup>(2)</sup>		Carbon steel	Cast or Ductile Iron	302 or 304 Stainless steel	CF8M or 316 Stainless steel	416 Stainless steel	Monel <sup>®</sup> (1)	Hastelloy <sup>®</sup> C <sup>(2)</sup>
Acetic Acid (Air Free)	C	C	B	B	C	B	A	Hydrochloric Acid (Air Free)	C	C	C	C	C	C	B
Acetic Acid Vapors	C	C	A	A	C	A	A	Hydrogen	A	A	A	A	A	A	A
Acetone	A	A	A	A	A	A	A	Hydrogen Peroxide	I.L.	A	A	A	B	A	B
Acetylene	A	A	A	A	A	A	A	Hydrogen Sulfide (Liquid)	C	C	A	A	C	C	A
Alcohols	A	A	A	A	A	A	A	Magnesium Hydroxide	A	A	A	A	A	A	A
Aluminum Sulfate	C	C	A	A	C	B	A	Methanol	A	A	A	A	A	A	A
Ammonia	A	A	A	A	A	A	A	Methyl Ethyl Ketone	A	A	A	A	A	A	A
Ammonium Chloride	C	C	B	B	C	B	A	Natural Gas	A	A	A	A	A	A	A
Ammonium Nitrate	A	C	A	A	C	C	A	Nitric Acid	C	C	A	B	C	C	B
Ammonium Sulfate	C	C	B	A	C	A	A	Petroleum Oils (Refined)	A	A	A	A	A	A	A
Ammonium Sulfite	C	C	A	A	B	C	A	Phosphoric Acid (Air Free)	C	C	A	A	C	B	A
Beer	B	B	A	A	B	A	A	Phosphoric Acid Vapors	C	C	B	A	C	C	I.L.
Benzene (Benzol)	A	A	A	A	A	A	A	Potassium Chloride	B	B	A	A	C	B	A
Benzoic Acid	C	C	A	A	A	A	A	Potassium Hydroxide	B	B	A	B	B	A	A
Boric Acid	C	C	A	A	B	A	A	Propane	A	A	A	A	A	A	A
Butane	A	A	A	A	A	A	A	Silver Nitrate	C	C	A	A	B	C	A
Calcium Chloride (Alkaline)	B	B	C	B	C	A	A	Sodium Acetate	A	A	B	A	A	A	A
Carbon Dioxide (Dry)	A	A	A	A	A	A	A	Sodium Carbonate	A	A	A	A	B	A	A
Carbon Dioxide (Wet)	C	C	A	A	A	A	A	Sodium Chloride	C	C	B	B	B	A	A
Carbon Disulfide	A	A	A	A	B	B	A	Sodium Chromate	A	A	A	A	A	A	A
Carbon Tetrachloride	B	B	B	B	C	A	A	Sodium Hydroxide	A	A	A	A	B	A	A
Carbonic Acid	C	C	B	B	A	A	A	Stearic Acid	A	C	A	A	B	B	A
Chlorine Gas (Dry)	A	A	B	B	C	A	A	Sulfur	A	A	A	A	A	A	A
Chlorine Gas (Wet)	C	C	C	C	C	C	B	Sulfur Dioxide (Dry)	A	A	A	A	B	A	A
Chlorine (Liquid)	C	C	C	C	C	C	A	Sulfur Trioxide (Dry)	A	A	A	A	B	A	A
Chromic Acid	C	C	C	B	C	A	A	Sulfuric Acid (Aerated)	C	C	C	C	C	C	A
Citric Acid	I.L.	C	B	A	B	B	A	Sulfuric Acid (Air Free)	C	C	C	C	C	B	A
Coke Oven Gas	A	A	A	A	A	B	A	Sulfurous Acid	C	C	B	B	C	C	A
Copper Sulfate	C	C	B	B	A	C	A	Trichloroethylene	B	B	B	A	B	A	A
Ether	B	B	A	A	A	A	A	Water (Boiler Feed)	B	C	A	A	B	A	A
Ethyl Chloride	C	C	A	A	B	A	A	Water (Distilled)	A	A	A	A	B	A	A
Ethylene	A	A	A	A	A	A	A	Water (Sea)	B	B	B	B	C	A	A
Ethylene Glycol	A	A	A	A	A	A	I.L.	Zinc Chloride	C	C	C	C	C	C	A
Formaldehyde	B	B	A	A	A	A	A	Zinc Sulfate	C	C	A	A	B	A	A
Formic Acid	I.L.	C	B	B	C	A	A	----	-	-	-	-	-	-	-
Freon (Wet)	B	B	B	A	I.L.	A	A	----	-	-	-	-	-	-	-
Freon (Dry)	B	B	A	A	I.L.	A	A	----	-	-	-	-	-	-	-
Gasoline (Refined)	A	A	A	A	A	A	A	----	-	-	-	-	-	-	-
Glucose	A	A	A	A	A	A	A	----	-	-	-	-	-	-	-
Hydrochloric Acid (Aerated)	C	C	C	C	C	C	B	----	-	-	-	-	-	-	-
A+--Best possible selection A--Recommended B--Minor to moderate effect. Proceed with caution.								C--Unsatisfactory I.L.--Information lacking							

- continued -

## Installation

Using a straight run of pipe the same size or larger than the regulator body, install the Type 1290 regulator as shown in Figure 1 so that flow through the main valve body matches the flow arrow cast on the body. A control and exhaust line as in Figure 2 is required. If a block valve is required, install

a full flow valve between the regulator and the blanketed vessel. For proper operation at low setpoint ranges, the regulators should be installed with the pilot spring case barrel pointed down.

Monel<sup>®</sup> is a mark owned by Special Metals Corporation.  
Hastelloy<sup>®</sup> C is a mark owned by Haynes International, Inc.

# Bulletin 74.2:1290

**Table 9. Materials Compatibility (continued)**

FLUID INFORMATION					
Fluid	Material				
	Neoprene (CR)	Nitrile (NBR)	Fluorocarbon (FKM)	Perfluorelastomer (FFKM)	Ethylenepropylene (EPDM)
Acetic Acid (30%)	C	B	B	A	A
Acetone	B	C	C	A	A
Alcohol (Ethyl)	A	A	B	A	A
Alcohol (Methyl)	A+	A	C	A	A
Ammonia (Anhydrous)	A	C	C	A	A
Ammonia (Gas, Hot)	B	C	C	A	B
Benzene	C	C	A	A	C
Brine (Calcium Chloride)	A	A	B	A	A
Butadiene Gas	B	C	B	A	C
Butane (Gas)	A	A+	A	A	C
Butane (Liquid)	B	A	A	A	C
Carbon Tetrachloride	C	C	A	A	C
Chlorine (Dry)	C	C	A	A	C
Chlorine (Wet)	C	C	A	A	C
Coke Oven Gas	C	B	A+	A	C
Ethyl Acetate	C	C	C	A	B
Ethylene Glycol	A	A	A	A	A
Freon 11	B	A	A+	A	C
Freon 12	A+	A	B	A	B
Freon 22	A+	C	C	A	A
Freon 114	A	A	B	A	A
Gasoline	B	A+	A	A	C
Hydrogen Gas	A	A	A	A	A
Hydrogen Sulfide (Dry)	A	C	C	A	A
Hydrogen Sulfide (Wet)	B	C	C	A	A
Jet Fuel (JP-4)	C	A	A	A	I.L.
Natural Gas	A	A+	A	A	C
Natural Gas + H <sub>2</sub> S (Sour Gas)	A	B	C	A	C
Nitric Acid (20%)	B	C	A	A	C
Nitric Acid (50 to 100%)	C	C	A	A	C
Nitrogen	A	A	A	A	A
Oil (Fuel)	B	A+	A	A	C
Propane	A	A	A	A	C
Sulfur Dioxide	B	A	A	A	A
Sulfuric Acid (to 50%)	A	C	A	A	A
Sulfuric Acid (50 to 100%)	B	C	A	A	B
Water (Ambient)	C	C	A	A	B
Water (at 200°F / 93°C)	A	A	A	A	A
Water (Sea)	C	B	B	A	A
A+--Best possible selection A--Recommended B--Minor to moderate effect. Proceed with caution.			C--Unsatisfactory I.L.--Information lacking		



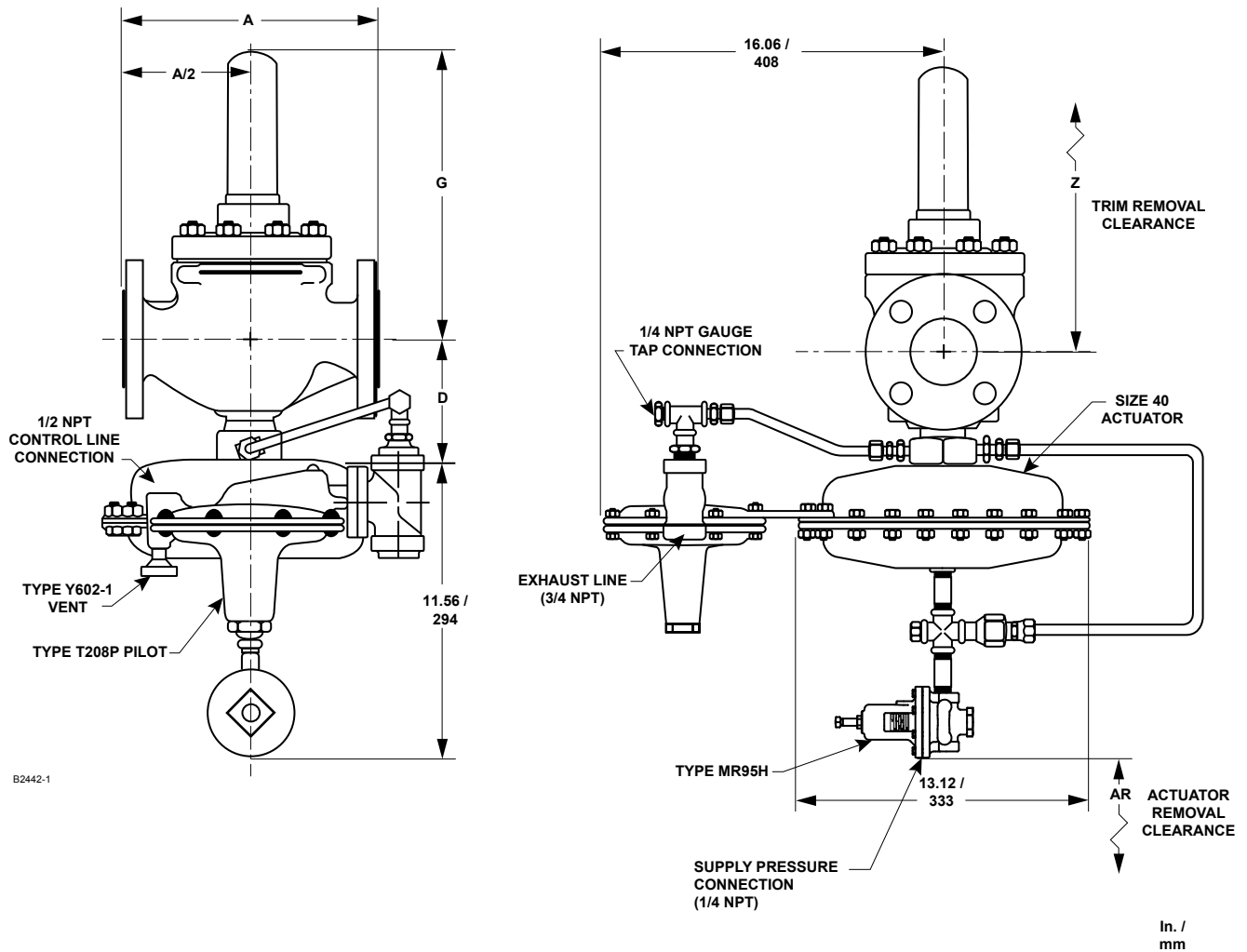

Figure 3. Type 1290 with Type T208P Pilot and Standard Closing Cap Dimensional Drawing

Table 10. Type 1290 Dimensions (See Figures 3 and 4)

MAIN VALVE BODY SIZE		DIMENSION																			
		A								D		G		Z				AR			
		NPT		CL125 FF Cast iron, or CL150 RF Steel or Stainless steel		CL250 FF Cast iron, or CL300 RF Steel or Stainless steel		CL600 RF Steel or Stainless steel						Cast iron		Stainless steel or Steel		Cast iron		Stainless steel or Steel	
NPS	DN	In.	mm	In.	mm	In.	mm	In.	mm	In.	mm	In.	mm	In.	mm	In.	mm	In.	mm		
1	25	8.25	210	7.25	184	7.75	197	8.25	210	3.88	99	8.62	219	12.00	305	10.50	267	3.00	76	2.44	62
2	50	11.25	286	10.00	254	10.50	267	11.25	286	4.56	116	9.12	232	13.31	338	11.81	300	3.12	79	3.12	79
3	80	---	---	11.75	298	12.50	317	13.25	337	5.31	135	11.25	286	16.50	419	14.00	356	3.88	99	3.88	99
4	100	---	---	13.88	353	14.50	368	15.50	394	6.50	165	12.62	321	19.12	486	16.88	429	5.12	130	5.12	130
6	150	---	---	17.75	451	18.62	473	20.00	580	7.25	184	13.69	348	20.44	519	19.19	487	6.38	162	6.62	168
8 x 6	200 x 150	---	---	21.40	544	22.40	569	24.00	610	9.76	248	15.02	382	20.25	514	23.25	591	6.62	168	6.62	168
12 x 6	300 x 150	---	---	29.00	737	30.50	775	32.25	819	9.76	248	15.02	382	---	---	23.25	591	---	---	6.62	168

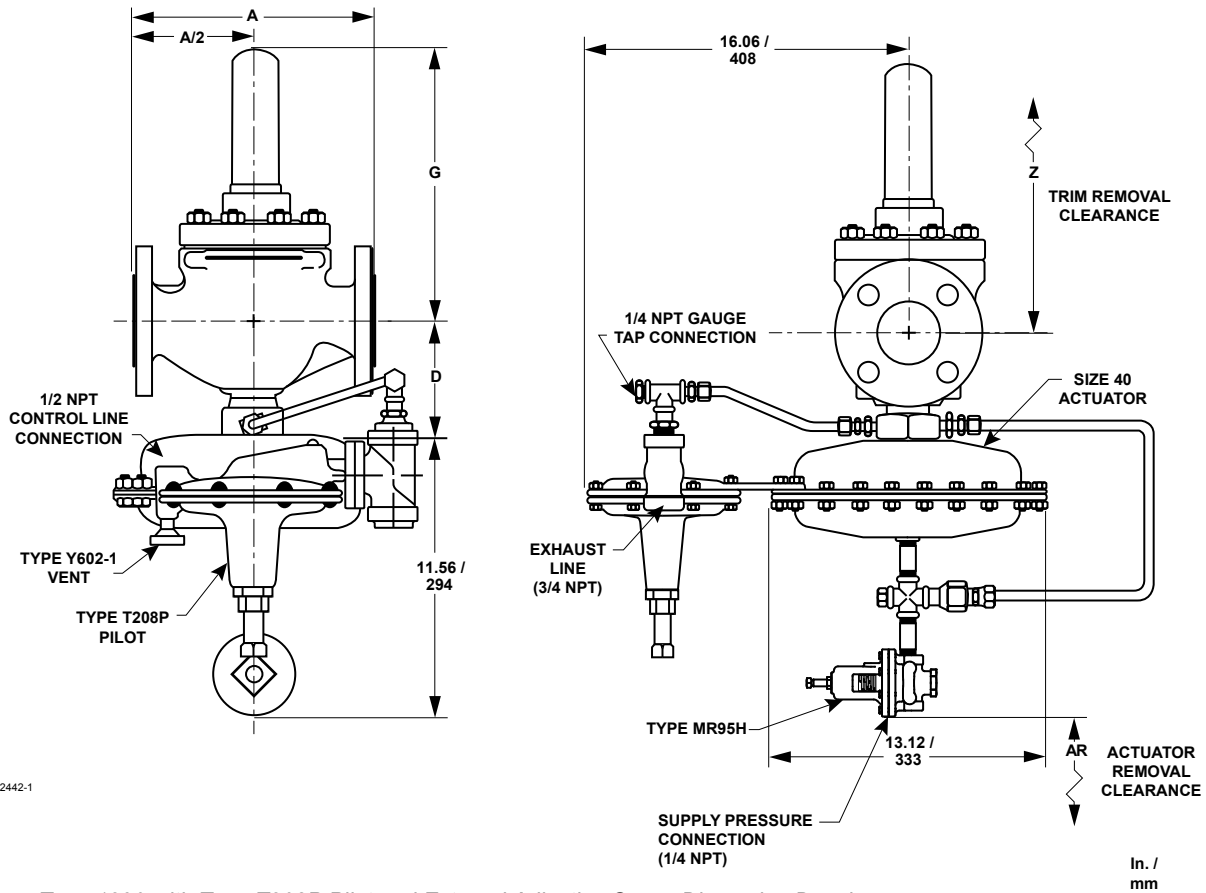

Figure 4. Type 1290 with Type T208P Pilot and External Adjusting Screw Dimension Drawing

## Ordering Information

Refer to the Specifications section on page 2 and Table 9 for reference for Material Compatibility. Carefully review the description of each specification and specify the desired

selection on the Ordering Guide page wherever there is a choice to be made.

## Ordering Guide

### Construction (Select One)

- Standard
- NACE

### Type EGR Main Valve

#### Main Valve Body Size (Select One)

- NPS 1 / DN 25\*\*\*
- NPS 2 / DN 50\*\*\*
- NPS 3 / DN 80\*\*\*
- NPS 4 / DN 100\*\*\*
- NPS 6 / DN 150\*\*
- NPS 8 x 6 / DN 200 x 150\*
- NPS 12 x 6 / DN 300 x 150\*

#### Main Valve Body Material (Select One)

- Cast Iron\*\*\*
- WCC Steel\*\*\*
- CF8M Stainless steel (NACE)\*\*

### Type EGR

#### Main Valve End Connection Style (Select One)

##### Cast Iron Body

- NPT (NPS 1 and 2 / DN 25 and 50 only)\*\*\*
- CL125 FF\*\*\*
- CL250 RF\*\*\*

##### WCC Steel or CF8M Stainless steel Body

- NPT (NPS 1 and 2 / DN 25 and 50 only)\*\*\*
- SWE (NPS 1 and 2 / DN 25 and 50 only)\*
- CL150 RF\*\*\*
- CL300 RF\*\*\*
- CL600 RF\*\*\*
- BWE 40\*\*
- BWE 80\*
- PN 16/25/40\* \_\_\_\_\_ please specify rating

- continued -

## Ordering Guide (continued)

### Type EGR (continued)

#### Main Valve Body Flange Material (Select One)

- Cast Iron\*\*\*
- WCC Steel\*\*\*
- CF8M Stainless steel (NACE)\*\*

#### Percent Travel or Travel Stop (Select One)

- 100 percent (standard)\*\*\*
- 70 percent (NPS 2 / DN 50 only)\*\*
- 40 percent (Not available for NPS 1 and 2 / DN 25 and 50)\*\*
- 30 percent (NPS 2 / DN 50 only)\*\*

#### Main Valve Cage Type and Material (Select One)

- Linear, CF8M Stainless steel (NACE)\*\*\*
- Whisper Trim™ Cage, 416 Stainless steel
- Whisper Trim Cage, 316 Stainless steel (NACE)
- Quick Opening, Cast Iron
- Quick Opening, Steel (for NPS 6 / DN 150 body only)

#### Main Valve Spring Range (Select One)

- 60 psig / 4.1 bar maximum drop, Green\*\*

#### Main Valve Spring

- Steel\*\*\*
- Inconel® X-750 (NACE)<sup>(1)</sup>\*\*\*

#### O-ring and Seal Material (Select One)

- Nitrile (NBR)\*\*\*
- Fluorocarbon (FKM)\*\*
- Ethylenepropylene (EPDM)\*\*
- Perfluoroelastomer (FFKM)

### Type 1098 Actuator

#### Lower Diaphragm Case Material (Select One)

- Steel\*\*\*
- Stainless steel\*\*

#### Bonnet Material (Select One)

- Steel\*\*\*
- Stainless steel\*\*

#### O-ring Material (Select One)

- Nitrile (NBR)\*\*\*
- Fluorocarbon (FKM)\*\*
- Ethylenepropylene (EPDM)\*\*

#### Diaphragm Material (Select One)

- Nitrile (NBR)\*\*\*
- Fluorocarbon (FKM)\*\*
- Ethylenepropylene (EPDM)\*\*

### Type MR95H Supply Pressure Regulator

#### Body Material (Select One)

- Cast Iron\*\*\*
- Steel\*\*\*
- Stainless steel\*\*\*

### Type MR95H

#### Spring Case Material (Select One)

- Cast Iron\*\*\*
- Steel\*\*\*
- Stainless steel\*\*\*

#### Valve Plug Material (Select One)

- 416 Stainless steel with Nitrile (NBR)\*\*\*
- 416 Stainless steel with Fluorocarbon (FKM)\*\*\*
- 316 Stainless steel with Neoprene (CR) (NACE)\*\*
- 316 Stainless steel with Fluorocarbon (FKM)\*\*

#### Outlet Pressure Range (Select One)

- 15 to 30 psig / 1.0 to 2.1 bar, Yellow\*\*\*

#### Diaphragm Material (Select One)

- Neoprene (CR)\*\*\*
- Fluorocarbon (FKM)\*\*

### Type T208P or T208PL Pilot

#### Body, Spring Case Assembly and Diaphragm Casing Material (Select One)

- Cast iron
- WCC Steel
- CF3M Stainless steel

#### Control Pressure Range (Select One)

##### Type T208PL

- 0.5 to 1.5 in. w.c. / 1 to 4 mbar, Black\*\*\*

##### Type T208P

- 1.0 to 2.5 in. w.c. / 2 to 6 mbar, Orange\*\*\*
- 2 to 7 in. w.c. / 5 to 17 mbar, Red\*\*\*
- 4 to 14 in. w.c. / 10 to 35 mbar, Unpainted\*\*\*
- 0.5 to 1.2 psig / 35 to 83 mbar, Yellow\*\*\*
- 1 to 2.5 psig / 0.07 to 0.17 bar, Green\*\*\*
- 2.5 to 4.5 psig / 0.17 to 0.31 bar, Light Blue\*\*\*
- 4.5 to 7 psig / 0.31 to 0.48 bar, Black\*\*\*

#### Diaphragm Material (Select One)

- Nitrile (NBR)\*\*\*
- Fluorocarbon (FKM)\*\*
- Fluorinated Ethylene Propylene (FEP)

#### O-ring and Seal Material (Select One)

- Nitrile (NBR)\*\*\*
- Fluorocarbon (FKM)\*\*
- Ethylenepropylene (EPDM)\*\*
- Perfluoroelastomer (FFKM)\*

#### Closing Cap Material (Select One)

##### Type T208PL

- Zinc

##### Type T208P

- Plastic\*\*\*
- Steel\*\*
- Stainless steel\*\*

#### Vent Assembly (Select One)

- Spring Case Up (Type Y602-11)\*\*\*
- Spring Case Down (Type Y602-1)\*\*\*

# Bulletin 74.2:1290

## Ordering Guide (continued)

### Parts Kits

#### Replacement Parts Kit (Optional)

- Yes, send one replacement parts kit to match this order for each unit.

#### Quick-Change Trim Package (Optional)

- Yes, send one main valve Quick-Change Trim Package to match this order.

#### Wireless Position Monitor Mounting Kit (Optional)

- Yes, send one mounting kit for mounting the Topworx™ 4310 or the Fisher® 4320 wireless position monitor.

Regulators Quick Order Guide	
***	Readily Available for Shipment
**	Allow Additional Time for Shipment
*	Special Order, Constructed from Non-Stocked Parts. Consult your local Sales Office for Availability.
Availability of the product being ordered is determined by the component with the longest shipping time for the requested construction.	

Hastelloy® C is a mark owned by Haynes International, Inc.

Specification Worksheet	
<b>Application Specifications:</b>	
Tank Size	_____
Pump In Rate	_____
Pump Out Rate	_____
Blanketing Gas (Type and Specific Gravity)	_____
<b>Pressure Requirements (Please Designate Units):</b>	
Maximum Inlet Pressure ( $P_{1max}$ )	_____
Minimum Inlet Pressure ( $P_{1min}$ )	_____
Control Pressure Setting ( $P_2$ )	_____
Maximum Flow ( $Q_{max}$ )	_____
<b>Accuracy Requirements:</b>	
<input type="checkbox"/> 0.25 in. w.c. / 0.60 mbar	<input type="checkbox"/> 0.5 in. w.c. / 1 mbar
<input type="checkbox"/> 1 in. w.c. / 2 mbar	<input type="checkbox"/> 2 in. w.c. / 5 mbar
<input type="checkbox"/> Other _____	
<b>Other Specifications:</b>	
Is a vapor recovery regulator required? <input type="checkbox"/> Yes <input type="checkbox"/> No	
Special Material Requirements: <input type="checkbox"/> Ductile iron <input type="checkbox"/> Steel	
<input type="checkbox"/> Stainless steel <input type="checkbox"/> Hastelloy® C <input type="checkbox"/> Other _____	
<b>Other Requirements:</b> _____	

### Industrial Regulators

#### Emerson Process Management Regulator Technologies, Inc.

USA - Headquarters  
McKinney, Texas 75070 USA  
Tel: +1 800 558 5853  
Outside U.S. +1 972 548 3574

Asia-Pacific  
Shanghai 201206, China  
Tel: +86 21 2892 9000

Europe  
Bologna 40013, Italy  
Tel: +39 051 419 0611

Middle East and Africa  
Dubai, United Arab Emirates  
Tel: +971 4811 8100

### Natural Gas Technologies

#### Emerson Process Management Regulator Technologies, Inc.

USA - Headquarters  
McKinney, Texas 75070 USA  
Tel: +1 800 558 5853  
Outside U.S. +1 972 548 3574

Asia-Pacific  
Singapore 128461, Singapore  
Tel: +65 6770 8337

Europe  
Bologna 40013, Italy  
Tel: +39 051 419 0611  
Chartres 28008, France  
Tel: +33 2 37 33 47 00

Middle East and Africa  
Dubai, United Arab Emirates  
Tel: +971 4811 8100

### TESCOM

#### Emerson Process Management Tescom Corporation

USA - Headquarters  
Elk River, Minnesota 55330-2445, USA  
Tels: +1 763 241 3238  
+1 800 447 1250

Europe  
Selmsdorf 23923, Germany  
Tel: +49 38823 31 287

Asia-Pacific  
Shanghai 201206, China  
Tel: +86 21 2892 9499

For further information visit [www.fisherregulators.com](http://www.fisherregulators.com)

The Emerson logo is a trademark and service mark of Emerson Electric Co. All other marks are the property of their prospective owners. Fisher is a mark owned by Fisher Controls International LLC, a business of Emerson Process Management.

The contents of this publication are presented for informational purposes only, and while every effort has been made to ensure their accuracy, they are not to be construed as warranties or guarantees, express or implied, regarding the products or services described herein or their use or applicability. We reserve the right to modify or improve the designs or specifications of such products at any time without notice.

Emerson Process Management Regulator Technologies, Inc. does not assume responsibility for the selection, use or maintenance of any product. Responsibility for proper selection, use and maintenance of any Emerson Process Management Regulator Technologies, Inc. product remains solely with the purchaser.