

# Type 1190 Low-Pressure Tank Blanketing Regulator

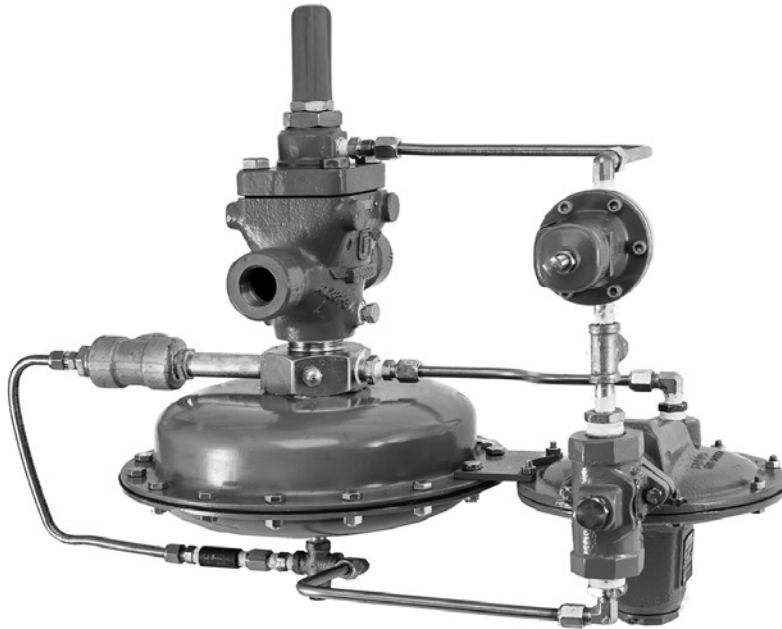

Figure 1. Type 1190 Tank Blanketing Regulator

## Introduction

The Type 1190 low-pressure tank blanketing regulator is used for extremely accurate pressure control on very low-pressure blanketing systems. The regulator helps to control emissions and provides protection against any contamination from atmospheric conditions by providing a flushing action. The Type 1190 tank blanketing regulator maintains a positive vessel pressure thereby reducing the possibility of vessel wall collapse during pump-out operations.

A Type 1190 low-pressure tank blanketing regulator reduces a high-pressure gas, such as Nitrogen, to maintain a protective environment above any liquid stored in a tank or vessel while the liquid is being pumped out. Also, when the vessel cools suddenly causing the vapors inside the vessel to condense, the tank blanketing regulator replaces the condensed vapors with the blanketing gas to prevent the internal vessel pressure from decreasing. In both cases, a slight positive vessel pressure prevents outside air, moisture and other contaminants from entering the vessel and the possible collapse of the vessel walls.

## Features

- **Quick-Change Trim Package**—Tested trim packages can be made up and stocked ahead of time for fast replacement.
- **In-Service Travel Inspection**—Standard indicator assembly with protective cover permits periodic inspection of plug travel without removing regulators from service.
- **Easy In-Line Maintenance**—Top-entry design reduces maintenance time and manpower requirements; trim parts can be inspected, cleaned and replaced without removing the main valve body from the pipeline.
- **Factory-Piped Pilot Supply**—Supply pressure to pilot is supplied from inlet side of the main valve body through tubing furnished with the regulator.

# Bulletin 74.1:1190

## Specifications

Specifications for a given regulator as it originally comes from the factory are stamped on nameplates located on the actuator and main valve body, while the pilot outlet pressure range appears on the pilot spring case nameplate.

### Body Sizes<sup>(1)</sup>

See Table 1

### Maximum Main Valve Inlet Pressures<sup>(2)</sup>

400 psig / 27.6 bar

### Maximum Operating Inlet Pressures<sup>(2)</sup>

200 psig / 13.8 bar with Cast iron construction or 300 psig / 20.7 bar with a Steel or Stainless steel construction

### Maximum Outlet (Casing) Pressure<sup>(2)</sup>

Steel or Stainless steel: 75 psig / 5.2 bar

### Maximum Operating Outlet Pressure to Avoid Internal Part Damage<sup>(2)</sup>

Nitrile (NBR) or Fluorocarbon (FKM) Diaphragm:  
75 psig / 5.2 bar

### Outlet Pressure Ranges (Type T205P Pilot)<sup>(2)</sup>

See Table 2

### Main Valve Orifice Diameters and Travels

See Table 3

### Proportional Bands

See Table 4

### Maximum and Minimum Differential Pressures

See Table 5

### Flow Coefficients for Relief Valve Sizing

See Table 8

### Flow Coefficients for Fixed Restriction

$C_g$ : 3;  $C_v$ : 11.7;  $C_1$ : 35

### Supply Pressure Settings Required for the Type MR95H Supply Pressure Regulator

See Table 9

### Flow Capacities

See Table 10

### Pressure Registration

External

### Main Valve Flow Characteristic

Linear

### Control Line Connection

3/4 NPT

### Vent Connection on Pilot Spring Case

1/4 NPT

### Main Valve Temperature Capabilities<sup>(2)</sup>

#### Nitrile (NBR):

-20 to 180°F / -29 to 82°C

#### Fluorocarbon (FKM):

40 to 300°F / 4 to 149°C

#### Ethylene propylene (EPDM):

-20 to 275°F / -29 to 135°C

#### Perfluoroelastomer (FFKM):

-20 to 300°F / -29 to 149°C

### Pilot Temperature Capabilities

Nitrile (NBR): -20 to 180°F / -29 to 82°C

Fluorocarbon (FKM): 40 to 180°F / 4 to 82°C

### Approximate Weights

NPS 1 / DN 25: 85 lbs / 39 kg

NPS 2 / DN 50: 100 lbs / 45 kg

NPS 3 / DN 80: 145 lbs / 66 kg

NPS 4 / DN 100: 195 lbs / 88 kg

NPS 6 / DN 150: 380 lbs / 172 kg

NPS 8 x 6 / DN 200 x 150: 740 lbs / 336 kg

NPS 12 x 6 / DN 300 x 150: 1265 lbs / 574 kg

### Construction Materials (See Table 11 for Reference Information as to Material Compatibility)

#### Type EGR Main Valve

Body and Body Flange: Cast iron and WCC steel

(standard) or CF8M Stainless steel (optional)

Seat Ring and Valve Plug: 416 Stainless steel

(standard) or 316 Stainless steel (optional)

Spring: Steel (standard) or Inconel® X750 (NACE)

O-rings and Seals: Nitrile (NBR) (standard),

Fluorocarbon (FKM) and

Perfluoroelastomer (FFKM) (optional)

Cage: Linear CF8M Stainless steel (standard),

416 Stainless steel Whisper Trim™ Cage (optional)

or 316 Stainless steel Whisper Trim Cage (NACE)

#### Type 1098 Actuator

Lower Diaphragm Case: Steel (standard) or Stainless steel

Upper Diaphragm Case: Steel (standard) or Stainless steel

Bonnet: Steel (standard) or Stainless steel (NACE)

Diaphragm and O-rings: Nitrile (NBR) (standard),

Fluorocarbon (FKM) or

Ethylene propylene (EPDM) (optional)

#### Type T205P Pilot

Body: Carbon steel or Stainless steel

Spring Case and Diaphragm Casing:

Carbon steel or Stainless steel

Orifice: 303 Stainless steel (standard) or

316 Stainless steel (NACE)

Spring: Steel (standard)

Diaphragm: Nitrile (NBR) (standard) or

Fluorocarbon (FKM)

O-rings, Gaskets and Seals: Nitrile (NBR) (standard),

Fluorocarbon (FKM), Perfluoroelastomer (FFKM)

or Ethylene propylene (EPDM) (optional)

Disk: Nitrile (NBR) (standard), Fluorocarbon (FKM)

or Ethylene propylene (EPDM) (optional)

Disk Holder: 303 Stainless steel (standard)

or 316 Stainless steel (NACE)

1. End connections other than U.S. standard can usually be provided; consult your local Sales Office.

2. The pressure/temperature limits in this Bulletin and any applicable standard or code limitation should not be exceeded.

- continued -

## Specifications (continued)

<p><b>Construction Materials (continued)</b>  <b>Type MR95H Supply Pressure Regulator</b>  <i>Body and Spring Case:</i> Cast iron (standard), steel, steel (NACE) and Stainless steel (optional)  <i>Orifice:</i> 416 Stainless steel (standard) or 316 Stainless steel (NACE)  <i>Valve Plug:</i> 416 Stainless steel with Nitrile (NBR) (standard), 416 Stainless steel with Fluorocarbon (FKM) or 316 Stainless steel with Neoprene (CR) (NACE)</p>	<p><i>Stem Assembly:</i> 416 Stainless steel (standard) or 316 Stainless steel (NACE)  <i>Lower Spring Seat:</i> Aluminum  <i>Upper Spring Seat:</i> Steel  <i>Spring:</i> Steel  <i>Diaphragm:</i> Neoprene (CR) (standard) or Fluorocarbon (FKM) (optional)</p>
--	---

**Table 1. Type EGR Main Valve Body Sizes and End Connection Styles**

MAIN VALVE BODY SIZE		MAIN VALVE END CONNECTION STYLE	
NPS	DN	Cast Iron	WCC Steel or CF8M Stainless Steel
1, 2	25, 50	NPT, CL125 FF or CL250 RF flanged	NPT, SWE, BWE, CL150 RF, CL300 RF, CL600 RF or PN 16/25/40 flanged
3, 4, 6	80, 100, 150	CL125 FF or CL250 RF flanged	BWE, CL150 RF, CL300 RF, CL600 RF or PN 16 flanged
8 x 6, 12 x 6	200 x 150, 300 x 150	----	BWE, CL150 RF, CL300 RF, CL600 RF flanged or PN 25

**Table 2. Outlet Pressure Ranges (Type T205P Pilot)**

OUTLET PRESSURE RANGE <sup>(1)</sup>		SPRING PART NUMBER	SPRING COLOR	SPRING WIRE DIAMETER		SPRING FREE LENGTH	
In. w.c.	mbar			In.	mm	In.	mm
0.25 to 2.5 <sup>(2)</sup>	0.6 to 6 <sup>(2)</sup>	1B558527052	Orange	0.072	1.83	3.25	82.6
2 to 7 <sup>(2)</sup>	5.0 to 17 <sup>(2)</sup>	1B653827052	Red	0.085	2.16	3.63	92.1
5 to 16	12 to 40	1B653927022	Unpainted	0.105	2.67	3.75	95.3
0.5 to 1.2 psig	34 to 83	1B537027052	Yellow	0.114	2.90	4.31	109
1.1 to 2.5 psig	76 to 172	1B537127022	Green	0.156	3.96	4.06	103
2.5 to 4.5 psig	172 mbar to 0.31 bar	1B537227022	Light blue	0.187	4.75	3.94	100
4.5 to 7.0 psig	0.31 to 0.48 bar	1B537327052	Black	0.218	5.54	3.98	101

1. Outlet pressure ranges based on pilot being installed with the spring case pointed down.  
2. Do not use Fluorocarbon (FKM) diaphragm with this spring at diaphragm temperatures lower than 60°F / 16°C.

**Table 3. Type EGR Main Valve Orifice Diameters and Valve Plug Travels**

BODY SIZE		ORIFICE DIAMETER		TRAVEL					
				Standard		Restricted Capacity			
						Percent	Travel		mm
NPS	DN	In.	mm	In.	mm		In.	mm	
1	25	1-5/16	33	3/4	19	----	----	----	
2	50	2-3/8	60	1-1/8	29	30	3/8	9.5	
						70	5/8	16	
3	80	3-3/8	86	1-1/2	38	40	7/8	22	
4	100	4-3/8	111	2	51	40	1	25	
6, 8 x 6, 12 x 6	150, 200 x 150, 300 x 150	7-3/16	183						

**Table 4. Proportional Bands - Type EGR Main Valve**

OUTLET PRESSURE RANGE		PROPORTIONAL BAND					
		Green Main Valve Spring		Blue Main Valve Spring		Red Main Valve Spring	
		Maximum Inlet Pressure 60 psig / 4.1 bar		Maximum Inlet Pressure Range 60 to 125 psig / 4.1 to 8.6 bar		Maximum Inlet Pressure Range 125 to 300 psig / 8.6 to 20.7 bar	
In. w.c.	mbar	In. w.c.	mbar	In. w.c.	mbar	In. w.c.	mbar
0.25 to 2.5	0.6 to 6	0.25	0.6	0.5	1	1	2
2 to 7	5.0 to 17	0.25	0.6	0.5	1	1	2
5 to 16	12 to 40	0.25	0.6	0.5	1	1	2
0.5 to 1.2 psig	34 to 83	0.05 psig	3	0.10 psig	7	0.15 psig	10
1.1 to 2.5 psig	76 to 172	0.10 psig	7	0.15 psig	10	0.20 psig	14
2.5 to 4.5 psig	172 mbar to 0.31 bar	0.15 psig	10	0.20 psig	14	0.25 psig	17
4.5 to 7.0 psig	0.31 to 0.48 bar	0.20 psig	14	0.25 psig	17	0.30 psig	21

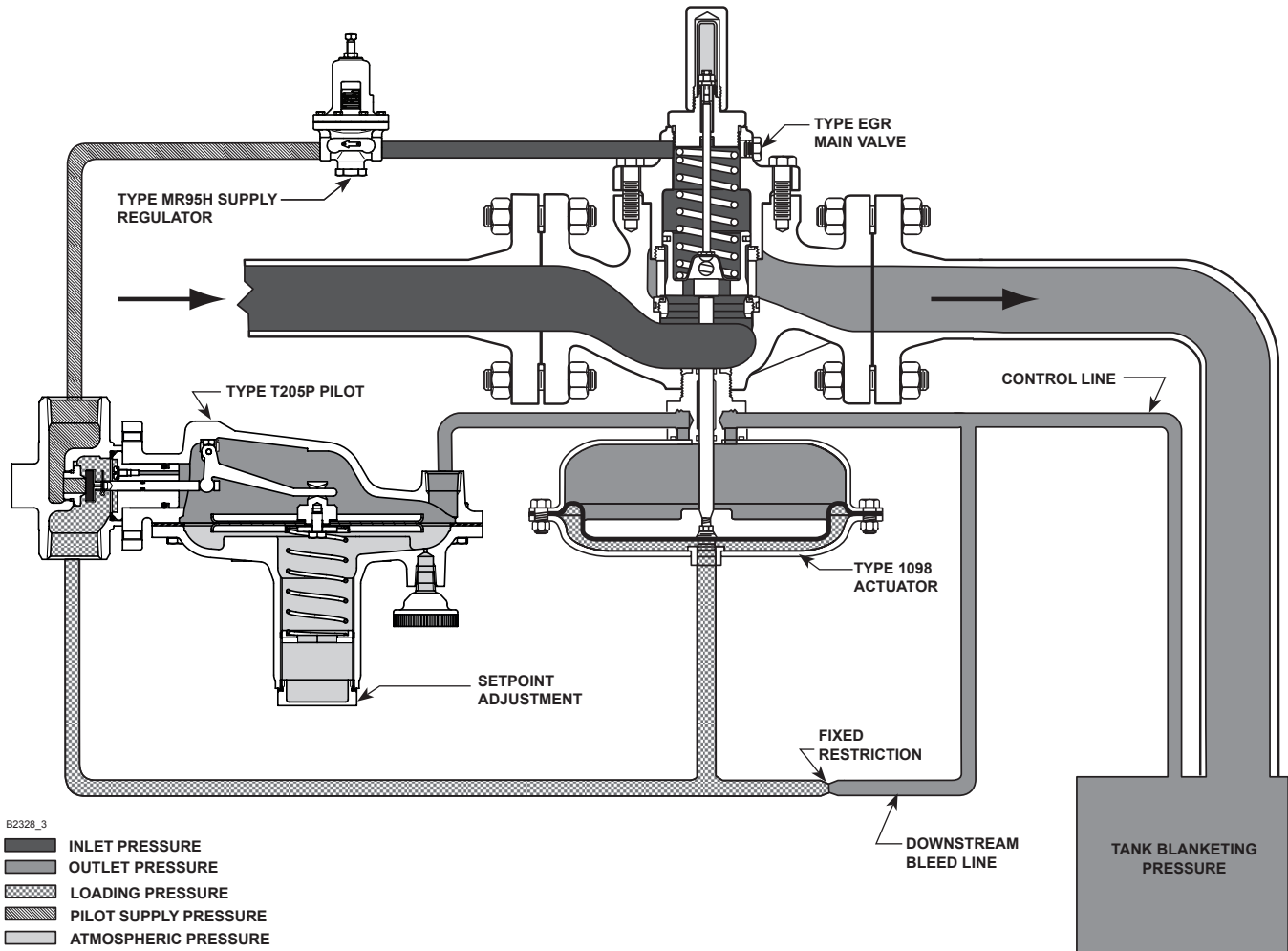

Figure 2. Operational Schematic

## Principle of Operation

The Type 1190 tank blanketing regulator reduces a high-pressure inert gas to maintain a positive low-pressure of blanket gas over a stored liquid while liquid is being pumped out of the tank. Also, when the tank suddenly cools causing tank vapors to condense, the Type 1190 regulator replaces the condensing vapors with an inert gas to prevent the internal tank pressure from decreasing. In both cases, a positive tank pressure prevents outside air from entering the vessel preventing contamination and reducing the possibility of atmospheric pressure collapsing the vessel.

The Type 1190 regulator is pilot-operated. It responds to slight decreases in internal tank pressure by throttling open to increase the flow rate of inert gas into the vessel. When the vessel's liquid level has been lowered to the desired point and the vapor pressure re-established, the Type 1190 regulator throttles closed.

The Type 1190 regulator utilizes a Type 1098-EGR main valve actuator (Type EGR main valve and Type 1098 actuator), a Type T205P sensing pilot and a Type MR95H supply pressure regulator. The Type T205P pilot uses the high-pressure inlet gas,

reduced by a Type MR95H supply pressure regulator, as loading pressure to operate the Type 1098-EGR main valve actuator. The outlet or vessel pressure is sensed through a control line on the Type 1098-EGR main valve actuator and also on the Type T205P pilot diaphragm.

When the liquid level is decreased and vessel pressure decreases below the pilot control spring setting, the pilot spring force on the pilot diaphragm opens the pilot valve plug, allowing additional loading pressure to the main valve actuator diaphragm. The loading pressure opens the main valve plug to supply the required flow of gas to the vessel.

When downstream demand has been satisfied, outlet pressure tends to increase slightly, acting on the pilot and main valve diaphragms. When the outlet pressure exceeds the pilot control spring setting, the pilot diaphragm moves to close the pilot valve plug. The loading pressure reduces by exhausting downstream through the fixed restriction, allowing the Type EGR main valve spring to close the Type EGR main valve plug. The combination of Type EGR main valve spring force and Type EGR main valve plug unbalance provides positive shutoff of the valve plug.

**Table 5. Maximum and Minimum Differential Pressures for Type EGR Main Valve Spring Selection**

BODY SIZE		TYPE EGR MAIN VALVE SPRING PART NUMBER	SPRING COLOR	MAXIMUM ALLOWABLE DIFFERENTIAL PRESSURE		MINIMUM DIFFERENTIAL PRESSURE REQUIRED FOR FULL STROKE	
NPS	DN			psig	bar	psig	bar
1	25	14A9687X012	Green	60	4.1	2.5	0.17
		14A9680X012	Blue	125	8.6	4	0.28
		14A9679X012	Red	300 or body rating limit, whichever is lower	20.7 or body rating limit, whichever is lower	5	0.34
2	50	14A6626X012	Green	60	4.1	3	0.21
		14A6627X012	Blue	125	8.6	5	0.34
		14A6628X012	Red	300 or body rating limit, whichever is lower	20.7 or body rating limit, whichever is lower	10	0.69
3	80	14A6629X012	Green	60	4.1	4	0.28
		14A6630X012	Blue	125	8.6	6	0.41
		14A6631X012	Red	300 or body rating limit, whichever is lower	20.7 or body rating limit, whichever is lower	11	0.76
4	100	14A6632X012	Green	60	4.1	5	0.34
		14A6633X012	Blue	125	8.6	8	0.55
		14A6634X012	Red	300 or body rating limit, whichever is lower	20.7 or body rating limit, whichever is lower	13	0.90
6, 8 x 6, 12 x 6	150, 200 x 150, 300 x 150	14A9686X012	Green	60	4.1	9.5	0.66
		14A9685X012	Blue	125	8.6	14	1.0
		15A2615X012	Red	300 or body rating limit, whichever is lower	20.7 or body rating limit, whichever is lower	19	1.3

**Table 6. Flow Rate Conversion (Gas Flow required to replace or displace Blanketing Gas with Pump-Out or Pump-In of Liquid)**

MULTIPLY MAXIMUM PUMP RATE IN:	BY	TO OBTAIN <sup>(1)</sup> :
U.S. GPM	8.021	SCFH of air required
U.S. GPH	0.1337	
Barrels/hour	5.615	
Barrels/day	0.2340	

1. To obtain Nm<sup>3</sup>/h, multiply SCFH by 0.0268.

**Table 7. Gas Flow Required for Thermal Heating (Outbreathing) or Cooling (Inbreathing) per American Petroleum Institute Standard 2000 (API 2000) (Interpolate for Intermediate sizes)**

Barrel	VESSEL CAPACITY			AIR FLOW RATE REQUIRED	
	Gallon	Liter	SCFH	Nm <sup>3</sup> /h	
60	2500	9500	60	1.6	
100	4200	16,000	100	2.7	
500	21,000	79,500	500	13.4	
1000	42,000	159,000	1000	26.8	
2000	84,000	318,000	2000	53.6	
3000	126,000	477,000	3000	80.4	
4000	168,000	636,000	4000	107	
5000	210,000	795,000	5000	134	
10,000	420,000	1,590,000	10,000	268	
15,000	630,000	2,385,000	15,000	402	
20,000	840,000	3,180,000	20,000	536	
25,000	1,050,000	3,975,000	24,000	643	
30,000	1,260,000	4,769,000	28,000	750	
35,000	1,470,000	5,564,000	31,000	831	
40,000	1,680,000	6,359,000	34,000	911	
45,000	1,890,000	7,154,000	37,000	992	
50,000	2,100,000	7,949,000	40,000	1072	
60,000	2,520,000	9,539,000	44,000	1179	
70,000	2,940,000	11,129,000	48,000	1286	
80,000	3,360,000	12,718,000	52,000	1394	
90,000	3,780,000	14,308,000	56,000	1501	
100,000	4,200,000	15,898,000	60,000	1608	
120,000	5,040,000	19,078,000	68,000	1822	
140,000	5,880,000	22,257,000	75,000	2010	
160,000	6,720,000	25,437,000	82,000	2198	
180,000	7,560,000	28,616,000	90,000	2412	

# Bulletin 74.1:1190

**Table 8. Flow Coefficients**

BODY SIZE		PIPING STYLE											
		Line Size Equals Body Size Piping											
		Linear Cage					Drilled Hole Whisper Trim™ Cage						
		C <sub>g</sub>		C <sub>v</sub>			C <sub>i</sub>	C <sub>g</sub>		C <sub>v</sub>			C <sub>i</sub>
Regulating	Wide-Open	Regulating	Wide-Open	Regulating	Wide-Open	Regulating		Wide-Open	Regulating	Wide-Open			
NPS	DN												
1	25	600	632	16.8	17.7	35.7	576	607	16.7	17.6	34.5		
2	50	2280	2400	63.3	66.7	36.0	1970	2080	54.7	57.8	36.0		
3	80	4630	4880	132	139	35.1	3760	3960	107	113	35.0		
4	100	7320	7710	202	213	36.2	6280	6610	180	190	34.8		
6	150	12,900	13,600	397	418	32.5	9450	9950	295	310	32.0		
8 x 6	200 x 150	18,480	19,450	578	608	32.0	10,660	11,220	305	321	35.0		
12 x 6	300 x 150	21,180	22,290	662	697	32.0	11,050	11,630	316	332	35.0		
BODY SIZE		2:1 Line Size to Body Size Piping											
		Standard Linear Cage					Drilled Hole Whisper Trim Cage						
		C <sub>g</sub>		C <sub>v</sub>			C <sub>i</sub>	C <sub>g</sub>		C <sub>v</sub>			C <sub>i</sub>
		Regulating	Wide-Open	Regulating	Wide-Open	Regulating		Wide-Open	Regulating	Wide-Open	Regulating	Wide-Open	
NPS	DN												
1	25	568	598	17.2	18.1	33.0	529	557	15.6	16.4	34.0		
2	50	2050	2160	59.6	62.8	34.4	1830	1930	52.3	55.1	35.0		
3	80	4410	4650	128	135	34.4	3630	3830	106	110	34.2		
4	100	6940	7310	198	209	35.0	6020	6340	171	180	35.2		
6	150	12,100	12,800	381	404	31.7	9240	9730	291	306	31.7		
8 x 6	200 x 150	17,370	18,280	543	571	32.0	10,020	10,550	286	301	35.0		
12 x 6	300 x 150	19,900	20,950	622	655	32.0	10,380	10,930	297	312	35.0		

**Table 9. Supply Pressure<sup>(1)</sup> Settings Required for the Type MR95H Regulator**

BODY SIZE		TYPE EGR MAIN VALVE SPRING PART NUMBER AND COLOR	SUPPLY PRESSURE															
			Type T205P Spring Color and Outlet Pressure Range															
			Orange 0.25 to 2.5 in. w.c. / 0.6 to 6 mbar		Red 2 to 7 in. w.c. / 5.0 to 17 mbar		Unpainted 5 to 16 in. w.c. / 12 to 40 mbar		Yellow 0.5 to 1.2 psig / 34 to 83 mbar		Green 1.1 to 2.5 psig / 76 to 172 mbar		Light Blue 2.5 to 4.5 psig / 172 mbar to 0.31 bar		Black 4.5 to 7.0 psig / 0.31 to 0.48 bar			
			psig	bar	psig	bar	psig	bar	psig	bar	psig	bar	psig	bar	psig	bar	psig	bar
NPS	DN																	
1	25	14A9687X012, Green	6	0.41	6	0.41	6	0.41	7	0.48	8	0.55	10	0.69	11	0.76	13	0.90
		14A9680X012, Blue	7	0.48	7	0.48	7	0.48	8	0.55	10	0.69	13	0.90	14	1.0		
		14A9679X012, Red	8	0.55	8	0.55	8	0.55	9	0.62	11	0.76	14	0.97	15	1.0		
2	50	14A6626X012, Green	6	0.41	6	0.41	6	0.41	7	0.48	9	0.62	12	0.83	13	0.90		
		14A6627X012, Blue	8	0.55	8	0.55	8	0.55	9	0.62	11	0.76	14	0.97	15	1.0		
		14A6628X012, Red	13	0.90	13	0.90	13	0.90	14	1.0	16	1.1	19	1.3	20	1.4		
3	80	14A6629X012, Green	7	0.48	7	0.48	7	0.48	8	0.55	10	0.69	13	0.90	14	1.0		
		14A6630X012, Blue	9	0.62	9	0.62	9	0.62	10	0.69	12	0.83	15	1.0	16	1.1		
		14A6631X012, Red	14	1.0	14	1.0	14	1.0	15	1.0	17	1.2	20	1.4	21	1.5		
4	100	14A6632X012, Green	8	0.55	8	0.55	8	0.55	9	0.62	11	0.76	14	1.0	15	1.0		
		14A6633X012, Blue	11	0.76	11	0.76	11	0.76	12	0.83	14	1.0	17	1.2	18	1.3		
		14A6634X012, Red	16	1.1	16	1.1	16	1.1	17	1.2	19	1.3	22	1.5	23	1.6		
6, 8 x 6, 12 x 6	150, 200 x 150, 300 x 150	14A9686X012, Green	13	0.90	13	0.90	13	0.90	14	1.0	15	1.0	18	1.2	20	1.4		
		14A9685X012, Blue	17	1.2	17	1.2	17	1.2	18	1.2	20	1.4	23	1.6	24	1.7		
		15A2615X012, Red	22	1.5	22	1.5	22	1.5	23	1.6	25	1.7	28	1.9	29	2.0		

1. The pressures shown in the table are the minimum supply pressures required by the pilot. If the inlet pressure is less than shown, an external pilot supply is necessary.

**Table 10. Flow Capacities in SCFH / Nm³/h of 0.97 Specific Gravity Nitrogen**

INLET PRESSURE		OUTLET PRESSURE		CAPACITIES IN SCFH / Nm³/h OF 0.97 SPECIFIC GRAVITY NITROGEN												
				NPS 1 / DN 25 Body		NPS 2 / DN 50 Body		NPS 3 / DN 80 Body		NPS 4 / DN 100 Body		NPS 6 / DN 150 Body				
psig	bar	psig	bar	SCFH	Nm³/h	SCFH	Nm³/h	SCFH	Nm³/h	SCFH	Nm³/h	SCFH	Nm³/h	SCFH	Nm³/h	
30	2.1	4 or less	0.28 or less	27,300	732	103,900	2785	204,000	5467	322,000	8630	580,000	15,544			
40	2.8	7 or less	0.48 or less	33,300	892	126,600	3393	257,000	6888	406,300	10,889	716,100	19,191			
50	3.5			39,400	1056	149,800	4015	304,000	8147	480,600	12,880	847,100	22,702			
60	4.1			45,500	1219	173,000	4636	351,000	9407	554,900	14,871	978,000	26,210			
70	4.8			51,600	1383	196,000	5253	398,000	10,666	629,200	16,863	1,108,900	29,719			
80	5.5			57,700	1546	220,000	5896	444,900	11,923	703,500	18,854	1,239,900	33,229			
90	6.2	64,000	1715	243,000	6512	491,900	13,183	777,800	20,845	1,370,800	36,737					
100	6.9	7 or less	0.48 or less	70,100	1879	266,000	7129	538,900	14,443	852,100	22,836	1,501,700	40,246			
120	8.3			82,300	2206	312,000	8362	632,900	16,962	1,000,600	26,816	1,763,600	47,264			
140	9.7			94,500	2533	359,000	9621	726,900	19,481	1,149,200	30,799	2,025,400	54,281			
160	11.0			107,000	2868	406,000	10,881	820,900	22,000	1,297,800	34,781	2,287,347	61,301			
180	12.4			119,000	3189	452,000	12,114	914,800	24,517	1,446,400	38,764	2,549,200	68,319			
200	13.8			131,000	3511	490,000	13,132	1,008,800	27,036	1,595,000	42,746	2,811,000	75,335			

Table 11. Materials Compatibility

CORROSION INFORMATION															
Fluid	Material							Fluid	Material						
	Carbon steel	Cast or Ductile Iron	302 or 304 Stainless Steel	CF8M or 316 Stainless steel	416 Stainless steel	Monel <sup>®</sup> (1)	Hastelloy <sup>®</sup> C <sup>(2)</sup>		Carbon steel	Cast or Ductile Iron	302 or 304 Stainless steel	CF8M or 316 Stainless steel	416 Stainless steel	Monel <sup>®</sup> (1)	Hastelloy <sup>®</sup> C <sup>(2)</sup>
Acetic Acid (Air Free)	C	C	B	B	C	B	A	Hydrochloric Acid (Air Free)	C	C	C	C	C	C	B
Acetic Acid Vapors	C	C	A	A	C	A	A	Hydrogen	A	A	A	A	A	A	A
Acetone	A	A	A	A	A	A	A	Hydrogen Peroxide	I.L.	A	A	A	B	A	B
Acetylene	A	A	A	A	A	A	A	Hydrogen Sulfide (Liquid)	C	C	A	A	C	C	A
Alcohols	A	A	A	A	A	A	A	Magnesium Hydroxide	A	A	A	A	A	A	A
Aluminum Sulfate	C	C	A	A	C	B	A	Methanol	A	A	A	A	A	A	A
Ammonia	A	A	A	A	A	A	A	Methyl Ethyl Ketone	A	A	A	A	A	A	A
Ammonium Chloride	C	C	B	B	C	B	A	Natural Gas	A	A	A	A	A	A	A
Ammonium Nitrate	A	C	A	A	C	C	A	Nitric Acid	C	C	A	B	C	C	B
Ammonium Sulfate	C	C	B	A	C	A	A	Petroleum Oils (Refined)	A	A	A	A	A	A	A
Ammonium Sulfite	C	C	A	A	B	C	A	Phosphoric Acid (Air Free)	C	C	A	A	C	B	A
Beer	B	B	A	A	B	A	A	Phosphoric Acid Vapors	C	C	B	A	C	C	I.L.
Benzene (Benzol)	A	A	A	A	A	A	A	Potassium Chloride	B	B	A	A	C	B	A
Benzoic Acid	C	C	A	A	A	A	A	Potassium Hydroxide	B	B	A	B	B	A	A
Boric Acid	C	C	A	A	B	A	A	Propane	A	A	A	A	A	A	A
Butane	A	A	A	A	A	A	A	Silver Nitrate	C	C	A	A	B	C	A
Calcium Chloride (Alkaline)	B	B	C	B	C	A	A	Sodium Acetate	A	A	B	A	A	A	A
Carbon Dioxide (Dry)	A	A	A	A	A	A	A	Sodium Carbonate	A	A	A	A	B	A	A
Carbon Dioxide (Wet)	C	C	A	A	A	A	A	Sodium Chloride	C	C	B	B	B	A	A
Carbon Disulfide	A	A	A	A	B	B	A	Sodium Chromate	A	A	A	A	A	A	A
Carbon Tetrachloride	B	B	B	B	C	A	A	Sodium Hydroxide	A	A	A	A	B	A	A
Carbonic Acid	C	C	B	B	A	A	A	Stearic Acid	A	C	A	A	B	B	A
Chlorine Gas (Dry)	A	A	B	B	C	A	A	Sulfur	A	A	A	A	A	A	A
Chlorine Gas (Wet)	C	C	C	C	C	C	B	Sulfur Dioxide (Dry)	A	A	A	A	B	A	A
Chlorine (Liquid)	C	C	C	C	C	C	A	Sulfur Trioxide (Dry)	A	A	A	A	B	A	A
Chromic Acid	C	C	C	B	C	A	A	Sulfuric Acid (Aerated)	C	C	C	C	C	C	A
Citric Acid	I.L.	C	B	A	B	B	A	Sulfuric Acid (Air Free)	C	C	C	C	C	B	A
Coke Oven Gas	A	A	A	A	A	B	A	Sulfurous Acid	C	C	B	B	C	C	A
Copper Sulfate	C	C	B	B	A	C	A	Trichloroethylene	B	B	B	A	B	A	A
Ether	B	B	A	A	A	A	A	Water (Boiler Feed)	B	C	A	A	B	A	A
Ethyl Chloride	C	C	A	A	B	A	A	Water (Distilled)	A	A	A	A	B	A	A
Ethylene	A	A	A	A	A	A	A	Water (Sea)	B	B	B	B	C	A	A
Ethylene Glycol	A	A	A	A	A	A	I.L.	Zinc Chloride	C	C	C	C	C	C	A
Formaldehyde	B	B	A	A	A	A	A	Zinc Sulfate	C	C	A	A	B	A	A
Formic Acid	I.L.	C	B	B	C	A	A	----	-	-	-	-	-	-	-
Freon (Wet)	B	B	B	A	I.L.	A	A	----	-	-	-	-	-	-	-
Freon (Dry)	B	B	A	A	I.L.	A	A	----	-	-	-	-	-	-	-
Gasoline (Refined)	A	A	A	A	A	A	A	----	-	-	-	-	-	-	-
Glucose	A	A	A	A	A	A	A	----	-	-	-	-	-	-	-
Hydrochloric Acid (Aerated)	C	C	C	C	C	C	B	----	-	-	-	-	-	-	-
A+--Best possible selection A--Recommended B--Minor to moderate effect. Proceed with caution.								C--Unsatisfactory I.L.--Information lacking							

### Capacity Information

Table 10 gives typical Nitrogen regulating capacities at selected inlet pressures and outlet pressure settings. Flows are in SCFH (at 60°F and 14.7 psia) and Nm<sup>3</sup>/h (at 0°C and 1.01325 bar) of 0.97 specific gravity Nitrogen. For gases of other specific gravities, multiply the given capacity of Nitrogen by 0.985, and divide by the square root of the appropriate specific gravity of the gas required.

To determine wide-open flow capacities for relief sizing, use the following formula: where,

- C<sub>1</sub> = C<sub>g</sub>/C<sub>v</sub> or 35 as shown in Table 8
- C<sub>g</sub> = gas sizing coefficient from Table 8
- G = gas specific gravity (air = 1)
- P<sub>1abs</sub> = inlet pressure, psia (psig + 14.7 psi = psia)
- ΔP = pressure drop across the regulator, psi (P<sub>1</sub> - P<sub>2</sub>)
- Q = gas flow rate, SCFH
- T = absolute gas temperature at inlet, °Rankine
- P<sub>2</sub> = outlet pressure, psig

$$Q = \sqrt{\frac{520}{GT}} C_g P_{1abs} \text{SIN} \left( \frac{3417}{C_1} \sqrt{\frac{\Delta P}{P_1}} \right) \text{DEG}$$

Monel<sup>®</sup> is a mark owned by Special Metals Corporation.  
Hastelloy<sup>®</sup> C is a mark owned by Haynes International, Inc.

# Bulletin 74.1:1190

**Table 11. Materials Compatibility (continued)**

Fluid	FLUID INFORMATION				
	Material				
	Neoprene (CR)	Nitrile (NBR)	Fluorocarbon (FKM)	Perfluorelastomer (FFKM)	Ethylenepropylene (EPDM)
Acetic Acid (30%)	C	B	B	A	A
Acetone	B	C	C	A	A
Alcohol (Ethyl)	A	A	B	A	A
Alcohol (Methyl)	A+	A	C	A	A
Ammonia (Anhydrous)	A	C	C	A	A
Ammonia (Gas, Hot)	B	C	C	A	B
Benzene	C	C	A	A	C
Brine (Calcium Chloride)	A	A	B	A	A
Butadiene Gas	B	C	B	A	C
Butane (Gas)	A	A+	A	A	C
Butane (Liquid)	B	A	A	A	C
Carbon Tetrachloride	C	C	A	A	C
Chlorine (Dry)	C	C	A	A	C
Chlorine (Wet)	C	C	A	A	C
Coke Oven Gas	C	B	A+	A	C
Ethyl Acetate	C	C	C	A	B
Ethylene Glycol	A	A	A	A	A
Freon 11	B	A	A+	A	C
Freon 12	A+	A	B	A	B
Freon 22	A+	C	C	A	A
Freon 114	A	A	B	A	A
Gasoline	B	A+	A	A	C
Hydrogen Gas	A	A	A	A	A
Hydrogen Sulfide (Dry)	A	C	C	A	A
Hydrogen Sulfide (Wet)	B	C	C	A	A
Jet Fuel (JP-4)	C	A	A	A	I.L.
Natural Gas	A	A+	A	A	C
Natural Gas + H <sub>2</sub> S (Sour Gas)	A	B	C	A	C
Nitric Acid (20%)	B	C	A	A	C
Nitric Acid (50 to 100%)	C	C	A	A	C
Nitrogen	A	A	A	A	A
Oil (Fuel)	B	A+	A	A	C
Propane	A	A	A	A	C
Sulfur Dioxide	B	A	A	A	A
Sulfuric Acid (to 50%)	A	C	A	A	A
Sulfuric Acid (50 to 100%)	B	C	A	A	B
Water (Ambient)	C	C	A	A	B
Water (at 200°F / 93°C)	A	A	A	A	A
Water (Sea)	C	B	B	A	A

A+--Best possible selection  
A--Recommended  
B--Minor to moderate effect. Proceed with caution.

C--Unsatisfactory  
I.L.--Information lacking

## Sizing Blanketing Systems

When sizing a tank blanketing regulator for a low-pressure blanketing application, you must consider the replacement of blanketing gas required for the liquid loss during pump out of the vessel plus the condensation and contraction of the vessel vapors during atmospheric thermal cooling.

Using procedures such as those established by the American Petroleum Institute Standard 2000 (API 2000), determine the flow of blanketing gas required.

1. Determine the gas flow rate required to replace the liquid being pumped out (see Table 6).
2. Determine the gas flow rate due to "inbreathing" caused by atmospheric thermal cooling (see Table 7).
3. Add results from steps 1 and 2, then select regulator size, based on total capacity required (see Table 10).

## Sample sizing problem:

Vessel Capacity ..... 50,000 barrels  
Pump In/Out Capacity ..... 100 GPM / 378 LPM  
Inlet Pressure Source ..... 60 psig / 4.1 bar of Nitrogen  
Desired Blanket Setpoint ..... 0.5 in. w.c. / 1.2 mbar

1. From Table 6 the desired air flow rate due to pump-out is 800 SCFH / 21 Nm<sup>3</sup>/h of air (100 GPM / 378 LPM x 8.021 = 802).
2. From Table 7 the desired air flow rate is 40,000 SCFH / 1072 Nm<sup>3</sup>/h of air due to thermal cooling. Total required flow rate of 40,800 SCFH / 1093 Nm<sup>3</sup>/h of air converts to 41,600 SCFH / 1115 Nm<sup>3</sup>/h of Nitrogen (40,800 x 1.018 = 41,534).
3. From Table 10, an NPS 1 / DN 25 body size would flow 45,500 SCFH / 1219 Nm<sup>3</sup>/h of Nitrogen at 60 psig / 4.1 bar inlet pressure. This would satisfy the desired flow rate of 41,600 SCFH / 1115 Nm<sup>3</sup>/h of Nitrogen.



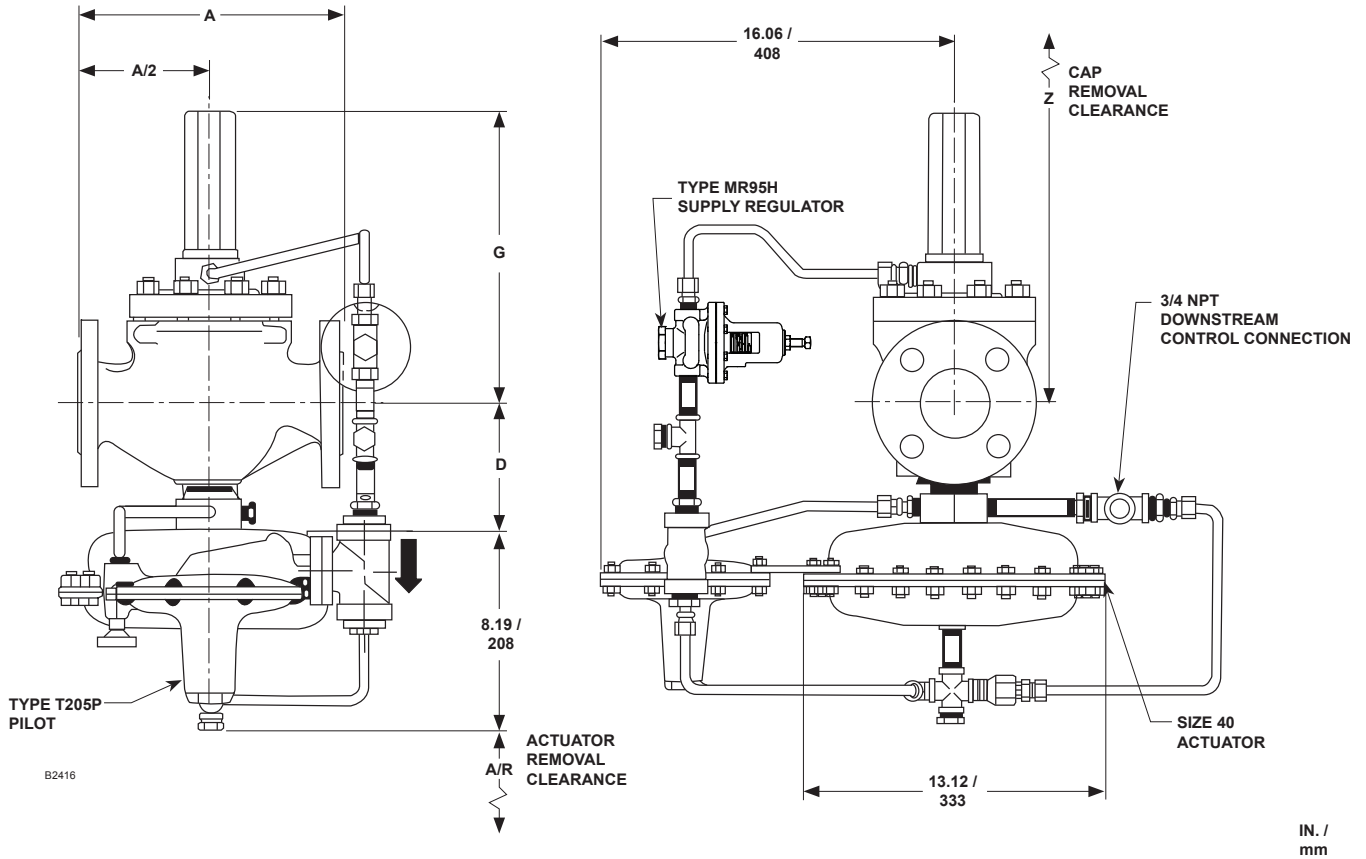

TYPE 1190 WITH STANDARD CLOSING CAP ON TYPE T205P PILOT REGULATOR

Figure 3. Type 1190 Dimensional Drawing

Table 12. Dimensions

MAIN VALVE BODY SIZE		DIMENSIONS															
		A								D	G	Z	A/R				
		NPT		CL125 FF Cast Iron or CL150 RF Steel or Stainless Steel		CL250 FF Cast Iron or CL300 RF Steel or Stainless Steel		CL600 RF Steel / Stainless Steel									
NPS	DN	In.	mm	In.	mm	In.	mm	In.	mm	In.	mm	In.	mm	In.	mm		
1	25	8.25	210	7.25	184	7.75	197	8.25	210	3.88	98.6	8.62	219	11.38	289	3.00	76.2
2	50	11.25	286	10.00	254	10.50	267	11.25	286	4.56	116	9.12	232	12.62	321	3.12	79.2
3	80	----	----	11.75	298	12.50	317	13.25	337	5.31	135	11.25	286	16.25	413	3.88	98.6
4	100	----	----	13.88	353	14.50	368	15.50	394	6.50	165	12.62	321	18.88	480	5.12	130
6	150	----	----	17.75	451	18.62	473	20.00	508	7.25	184	13.69	348	20.00	508	6.38	162

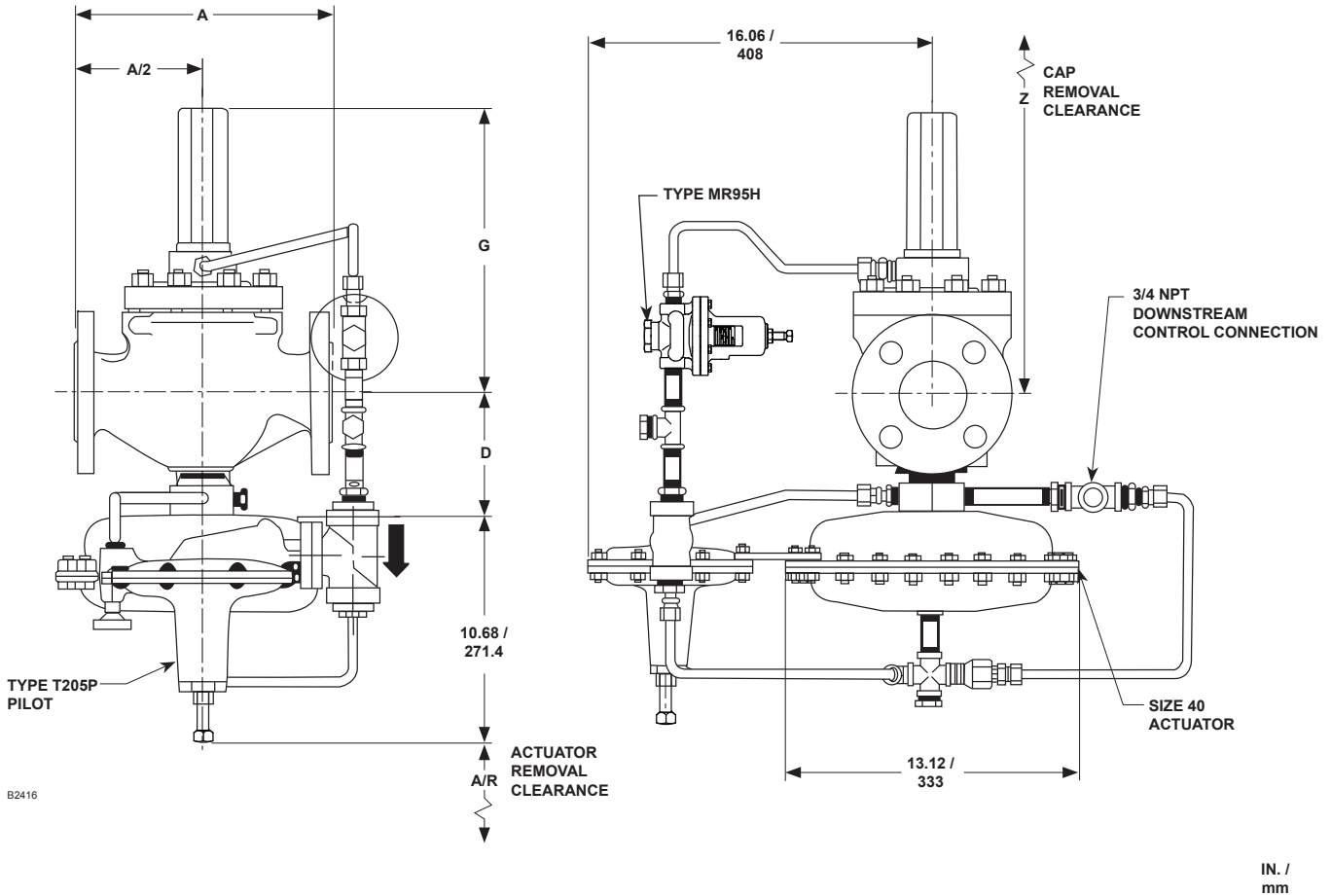

TYPE 1190 WITH EXTERNAL ADJUSTING SCREW ON TYPE T205P PILOT REGULATOR

Figure 3. Type 1190 Dimensional Drawing (continued)

## Installation

Using a straight run of pipe the same size or larger than the regulator body, install the Type 1190 regulator as shown in Figure 1 so that flow through the main valve body matches the flow arrow cast on the body. A downstream control line as shown in Figure 2 is required. If a block valve is required, install a full flow valve between the regulator and the blanketed vessel. For proper operation at low set point ranges, the regulator should be installed with the pilot spring case barrel pointed down.

External dimensions and connections are shown in Figure 3.

## Ordering Information

Please complete the specifications worksheet at the bottom of the Ordering Guide on page 12. Refer to the Specifications section on pages 2 and 3 and to Table 11 for material compatibility. Carefully review each specification, then complete the Ordering Guide on pages 11 and 12. Right-side pilot mounting will be provided as standard unless left-side mounting is specified.

## Ordering Guide

### Construction (Select One)

- Standard
- NACE

### Type EGR Main Valve

#### Main Valve Body Size (Select One)

- NPS 1 / DN 25\*\*\*
- NPS 2 / DN 50\*\*\*
- NPS 3 / DN 80\*\*\*
- NPS 4 / DN 100\*\*\*
- NPS 6 / DN 150\*\*
- NPS 8 x 6 / DN 200 x 150\*
- NPS 12 x 6 / DN 300 x 150\*

#### Main Valve Body Material (Select One)

- Cast iron\*\*\*
- WCC steel\*\*\*
- CF8M Stainless steel (NACE)\*\*\*

#### Main Valve End Connection Style (Select One)

##### Cast Iron Body

- NPT (Available for 1 or 2 NPT body sizes only)\*\*\*
- CL125 FF\*\*\*
- CL250 RF\*\*\*

##### WCC Steel or CF8M Stainless Steel Body

- NPT (Available for 1 or 2 NPT body sizes only)\*\*\*
- SWE\*
- CL150 RF\*\*\*
- CL300 RF\*\*\*
- CL600 RF\*\*\*
- BWE 40\*\*
- BWE 80\*
- PN 16/25/40\*\* \_\_\_\_\_ please specify rating

#### Main Valve Body Flange Material (Select One)

- Cast iron\*\*\*
- WCC steel\*\*\*
- CF8M Stainless steel (NACE)\*\*

#### Travel Stop (Select One)

- 100 percent (standard)\*\*\*
- 60 percent\*\*
- 30 percent\*\*

#### Main Valve Cage Type and Material (Select One)

- Linear, CF8M Stainless steel (NACE)\*\*\*
- Whisper Trim™ Cage, 416 Stainless steel\*\*\*
- Whisper Trim Cage, 316 Stainless steel (NACE)\*\*\*

#### Main Valve Spring Range (Select One)

- 60 psig / 4.1 bar maximum drop, Green\*\*
- 125 psig / 8.6 bar maximum drop, Blue\*\*\*
- 400 psig / 27.6 bar maximum drop, Red\*\*\*

#### Main Valve Spring Material

- Steel\*\*\*
- Inconel® X750 (NACE)\*\*\*

#### O-ring and Seal Material (Select One)

- Nitrile (NBR)\*\*\*
- Fluorocarbon (FKM)\*\*\*
- Perfluoroelastomer (FFKM)\*\*\*
- Ethylenepropylene (EPDM)\*\*

## Type T205P Pilot

### Body Material (Select One)

- Carbon steel
- Stainless steel

### Spring Case Material (Select One)

- Carbon steel
- Stainless steel

### Diaphragm Casing Material

- Carbon steel
- Stainless steel

### Outlet Pressure Range (Select One)

- 0.25 to 2.5 in. w.c. / 0.6 to 6 mbar\*\*\*
- 2 to 7 in. w.c. / 5.0 to 17 mbar\*\*\*
- 5 to 16 in. w.c. / 12 to 40 mbar\*\*\*
- 0.5 to 1.2 psig / 34 to 83 mbar\*\*\*
- 1.1 to 2.5 psig / 76 to 172 mbar
- 2.5 to 4.5 psig / 172 mbar to 0.31 bar\*\*\*
- 4.5 to 7.0 psig / 0.31 to 0.48 bar\*\*\*

### Diaphragm Material (Select One)

- Nitrile (NBR)\*\*\*
- Fluorocarbon (FKM)\*\*

### O-ring and Seal Material (Select One)

- Nitrile (NBR)\*\*\*
- Fluorocarbon (FKM)\*\*
- Ethylenepropylene (EPDM)\*\*
- Perfluoroelastomer (FFKM)\*

### Closing Cap Material (Select One)

- Plastic\*\*\*
- Steel\*\*
- Stainless steel\*\*

### NACE Required

- Yes\*\*\*

## Type 1098 Actuator

### Lower Diaphragm Case Material (Select One)

- Steel\*\*\*
- Stainless steel (NACE)\*\*

### Bonnet Material (Select One)

- Steel\*\*\*
- Stainless steel (NACE)\*\*

### O-ring Material (Select One)

- Nitrile (NBR)\*\*\*
- Fluorocarbon (FKM)\*\*\*
- Ethylenepropylene (EPDM)\*\*

### Diaphragm Material (Select One)

- Nitrile (NBR)\*\*\*
- Fluorocarbon (FKM)\*\*\*
- Ethylenepropylene (EPDM)\*\*

## Type MR95H Supply Pressure Regulator

### Body Material (Select One)

- Cast iron\*\*\*
- Steel\*\*\*
- Stainless steel (NACE)\*\*\*

### Spring Case Material (Select One)

- Cast iron\*\*\*
- Steel\*\*\*
- Stainless steel\*\*\*

# Bulletin 74.1:1190

## Ordering Guide (continued)

### Type MR95H Supply Pressure Regulator (continued)

#### Valve Plug Material (Select One)

- 416 Stainless steel with Nitrile (NBR)\*\*\*
- 416 Stainless steel with Fluorocarbon (FKM)\*\*\*
- 316 Stainless steel with Neoprene (CR) (NACE)\*\*

#### Outlet Pressure Range (Select One)

- 5 to 30 psig / 0.34 to 2.1 bar, Yellow\*\*\*

#### Diaphragm Material (Select One)

- Neoprene (CR)\*\*\*
- Fluorocarbon (FKM)\*\*\*

## Parts Kit

### Replacement Parts Kit (Optional)

- Yes, send one replacement parts kit to match this order for each unit.

### Quick-Change Trim Package (Optional)

- Yes, send one main valve Quick-Change Trim Package to match this order.

Regulators Quick Order Guide	
***	Readily Available for Shipment
**	Allow Additional Time for Shipment
*	Special Order, Constructed from Non-Stocked Parts. Consult your local Sales Office for Availability.
Availability of the product being ordered is determined by the component with the longest shipping time for the requested construction.	

### Wireless Position Monitor Mounting Kit (Optional)

- Yes, send one mounting kit for mounting the Topworx™ 4310 or the Fisher® 4320 wireless position monitor.

Specification Worksheet	
<b>Application Specifications:</b>	
Tank Size	_____
Pump In Rate	_____
Pump Out Rate	_____
Blanketing Gas (Type and Specific Gravity)	_____
<b>Pressure Requirements (Please Designate Units):</b>	
Maximum Inlet Pressure ( $P_{1max}$ )	_____
Minimum Inlet Pressure ( $P_{1min}$ )	_____
Control Pressure Setting ( $P_2$ )	_____
Maximum Flow ( $Q_{max}$ )	_____
<b>Accuracy Requirements:</b>	
<input type="checkbox"/> 0.25 in. w.c. / 0.6 mbar	<input type="checkbox"/> 0.5 in. w.c. / 1 mbar
<input type="checkbox"/> 1 in. w.c. / 2 mbar	<input type="checkbox"/> 2 in. w.c. / 5 mbar
<input type="checkbox"/> Others _____	
<b>Other Specifications:</b>	
Is a vapor recovery regulator required? <input type="checkbox"/> Yes <input type="checkbox"/> No	
Special Material Requirements: <input type="checkbox"/> Ductile Iron <input type="checkbox"/> Steel	
<input type="checkbox"/> Stainless Steel <input type="checkbox"/> Other _____	
Other Requirements: _____	
_____	
_____	

## Industrial Regulators

### Emerson Process Management Regulator Technologies, Inc.

USA - Headquarters  
McKinney, Texas 75070 USA  
Tel: +1 800 558 5853  
Outside U.S. +1 972 548 3574

Asia-Pacific  
Shanghai 201206, China  
Tel: +86 21 2892 9000

Europe  
Bologna 40013, Italy  
Tel: +39 051 419 0611

Middle East and Africa  
Dubai, United Arab Emirates  
Tel: +971 4811 8100

## Natural Gas Technologies

### Emerson Process Management Regulator Technologies, Inc.

USA - Headquarters  
McKinney, Texas 75070 USA  
Tel: +1 800 558 5853  
Outside U.S. +1 972 548 3574

Asia-Pacific  
Singapore 128461, Singapore  
Tel: +65 6770 8337

Europe  
Bologna 40013, Italy  
Tel: +39 051 419 0611  
Chartres 28008, France  
Tel: +33 2 37 33 47 00

Middle East and Africa  
Dubai, United Arab Emirates  
Tel: +971 4811 8100

## TESCOM

### Emerson Process Management Tescom Corporation

USA - Headquarters  
Elk River, Minnesota 55330-2445, USA  
Tels: +1 763 241 3238  
+1 800 447 1250

Europe  
Selmsdorf 23923, Germany  
Tel: +49 38823 31 287

Asia-Pacific  
Shanghai 201206, China  
Tel: +86 21 2892 9499

For further information visit [www.fisherregulators.com](http://www.fisherregulators.com)

The Emerson logo is a trademark and service mark of Emerson Electric Co. All other marks are the property of their prospective owners. Fisher is a mark owned by Fisher Controls International LLC, a business of Emerson Process Management.

The contents of this publication are presented for informational purposes only, and while every effort has been made to ensure their accuracy, they are not to be construed as warranties or guarantees, express or implied, regarding the products or services described herein or their use or applicability. We reserve the right to modify or improve the designs or specifications of such products at any time without notice.

Emerson Process Management Regulator Technologies, Inc. does not assume responsibility for the selection, use or maintenance of any product. Responsibility for proper selection, use and maintenance of any Emerson Process Management Regulator Technologies, Inc. product remains solely with the purchaser.