

Fisher™ 1080 Declutchable Manual Actuator

Contents

Introduction	1
Scope of Manual	1
Description	2
Specifications	2
Educational Services	2
Installation	4
Installing the Manual Actuator	4
Operation	5
Engaging the Manual Actuator	6
Disengaging the Manual Actuator	6
Maintenance	7
Lubrication	8

Figure 1. Fisher 1080 Manual Actuator Mounted on a FieldQ Actuator



Introduction

Scope of Manual

This instruction manual includes installation, operation, and maintenance information for the Fisher 1080 Declutchable Manual Actuator. Refer to separate instruction manuals for instructions covering the FieldQ actuator and the control valve.

Do not install, operate, or maintain a 1080 manual actuator without being fully trained and qualified in valve, actuator, and accessory installation, operation, and maintenance. To avoid personal injury or property damage, it is important to carefully read, understand, and follow all the contents of this manual, including all safety cautions and warnings. If you have any questions about these instructions, contact your [Emerson sales office](#) or Local Business Partner before proceeding.

Table 1. Specifications

<p>Available Configurations Direct acting; see Handwheel Rotation</p> <p>Manual Actuator Sizes See table 2</p> <p>Power Actuator Compatibility Compatible with FieldQ actuator; see table 2</p> <p>Maximum Torque Output See table 2</p> <p>Wheel-Rim Force See table 2</p> <p>Handwheel Rotation Clockwise handwheel rotation closes valve (produces clockwise valve shaft rotation)</p> <p>Mounting Positions Standard mounting is with the input shaft perpendicular to the FieldQ piston travel and the</p>	<p>handwheel opposite the actuator supply connections (see figure 2). Right hand or left hand mounting is specified when ordered. Mounting position 1 is standard.</p> <p>Approximate Weight without Handwheel</p> <p>Size AAA: 5.4 kg (12 lb) Size AA: 10 kg (22 lb) Size A: 14 kg (31 lb) Size B: 22 kg (49 lb) Size C: 34 kg (76 lb) Size D: 52 kg (115 lb) Size F: 68 kg (150 lb)</p> <p>Handwheel Weight</p> <p>8-inch: 2.0 kg (4.50 lb) 12-inch: 4.0 kg (8.75 lb) 16-inch: 6.8 kg (15.00 lb) 24-inch: 5.4 kg (12.00 lb) 30-inch: 6.8 kg (15.00 lb) 36-inch: 7.8 kg (17.25 lb)</p>
--------------------------------------------------------------------------------------------------------------------------------------------------------------------------------------------------------------------------------------------------------------------------------------------------------------------------------------------------------------------------------------------------------------------------------------------------------------------------------------------------------------------------------------------------------------------------------------------------	---------------------------------------------------------------------------------------------------------------------------------------------------------------------------------------------------------------------------------------------------------------------------------------------------------------------------------------------------------------------------------------------------------------------------------------------------------------------------------------------------------------------------------------------------------------------------------------------------------------------------------------------------

Description

The 1080 manual actuator, shown in figure 1, is a declutchable unit for manual operation of Fisher control valves that use a FieldQ power actuator. The 1080 manual actuator mounts directly on the FieldQ actuator. It can be engaged to allow manual operation of the valve when the power actuator is not in use or disengaged to allow automatic operation of the valve by the power actuator. The mechanism used allows manual actuator engagement at any point of power actuator rotation.

Specifications

The 1080 manual actuator specifications are given in table 1.

Educational Services

For information on available courses for 1080 manual actuators, as well as a variety of other products, contact:

Emerson Automation Solutions
Educational Services - Registration
Phone: 1-641-754-3771 or 1-800-338-8158
E-mail: education@emerson.com
emerson.com/fishervalvetraining

Figure 2. Fisher 1080 Actuator Mounting Positions

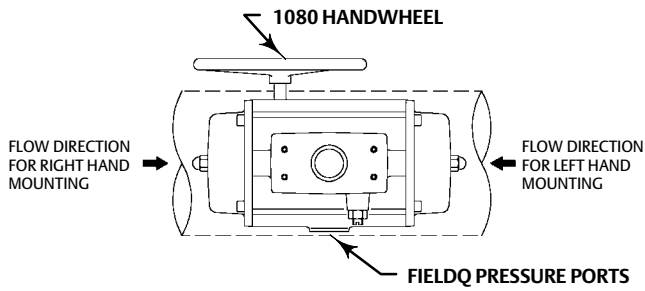

FOR USE WITH FIELDQ ACTUATOR

**MOUNTING POSITION 1
(STANDARD)**

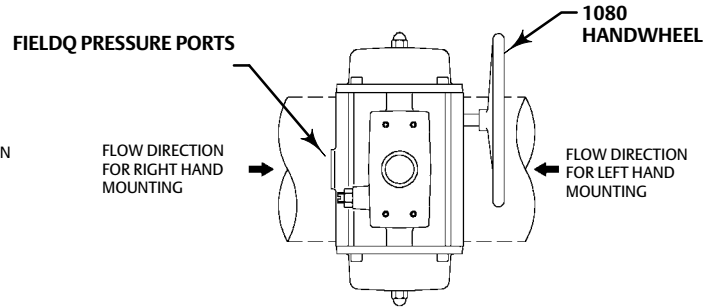

FOR USE WITH FIELDQ ACTUATOR SIZES Q25 THRU Q350
NOT AVAILABLE FOR FIELDQ ACTUATOR SIZES Q600 THRU Q1600

MOUNTING POSITION 2

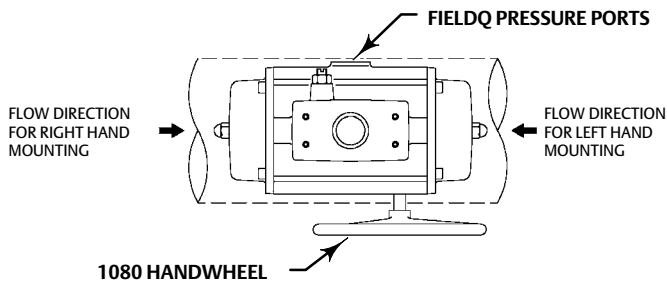

FOR USE WITH FIELDQ ACTUATOR

MOUNTING POSITION 3

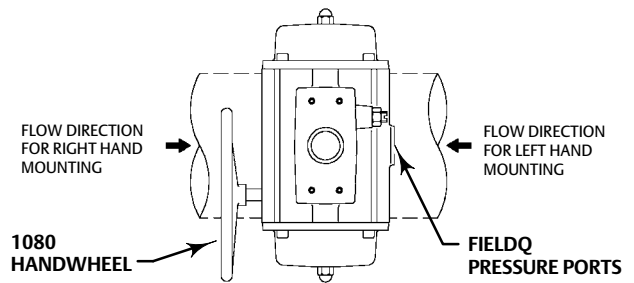

FOR USE WITH FieldQ ACTUATOR SIZES Q25 THRU Q350
NOT AVAILABLE FOR FieldQ ACTUATOR SIZES Q600 THRU Q1600

MOUNTING POSITION 4

NOTE:

Right and left hand mounting is based on the 8580 valve drive shaft being mounted in the recommended horizontal position.

7580768
82702

Installation

The 1080 manual actuator is normally shipped mounted between the valve assembly and the FieldQ actuator. If the manual actuator is shipped separately for installation on the FieldQ actuator, or if the manual actuator was removed for maintenance, mount the manual actuator by following the instructions in this section.

Field conversion of the FieldQ actuator for use with the 1080 manual actuator requires fastening an adaptor plate, included with the manual actuator, to the FieldQ actuator. The 1080 actuator is installed between the valve and the FieldQ actuator.

Figure 2 shows the manual actuator mounting positions. Positions 1 and 3 are possible with all sizes of the FieldQ. Positions 2 and 4 are only possible for FieldQ sizes Q40 through Q350 and Q1600. Fasten the adaptor plate to the power actuator with the mounting bolts provided with the manual actuator. Use the torque values given in table 3.

Installing the Manual Actuator

If you purchased the 1080 actuator as part of a valve and power actuator assembly, step 13 is the only step you will need to perform in the following procedures. If you purchased the 1080 actuator separately, perform all the steps and read all warnings and cautions below.

⚠ WARNING

Refer to the WARNING at the beginning of the Maintenance section in this instruction manual.

1. Isolate the control valve from the line pressure, release pressure from both sides of the valve body, and drain the process media from both sides of the valve. Also shut off all pressure lines to the power actuator and release all pressure from the power actuator. Use lock-out procedures to be sure that the above measures stay in effect while you work on the equipment.
2. For spring-return power actuators, allow the power actuator to remain in the position where the spring is relaxed. For double-acting power actuators, apply supply pressure as appropriate to position the valve disc in either the open or closed position.
3. Note whether the valve disc is in the open or closed position.
4. Engage the handwheel on the manual actuator. See the Engaging and Disengaging the Manual Actuator section in this manual for instructions.
5. If using position 1 or 3 from figure 2, rotate the handwheel to line up the index mark on the top of the manual actuator shaft and the drive shaft on the top of the power actuator. If using position 2 or 4 from figure 2, the index mark on top of the power actuator input drive on the 1080 must be perpendicular to the face of the valve disc and the slot in the top of the power actuator shaft (see figure 3).
6. Determine the correct relative positions of the power and manual actuators (see figure 2).
7. Remove the adaptor plate on the top of the gear box (see figure 3).
8. Attach the adaptor plate to the bottom of the power actuator with bolts furnished with the adaptor plate.
9. Slide the power actuator input drive into the power actuator (see figure 3).
10. Rotate either the manual actuator or the power actuator slightly so that the mounting holes on the manual actuator align with the mounting holes in the mounting plate on the power actuator.
11. Fasten the manual actuator to the mounting plate with the bolts, washers and nuts provided (see table 3).
12. Install the power actuator and manual actuator assembly on the valve as described in the installation section of the power actuator instruction manual. Remember the positions noted in steps 3 and 6, because you will need them when aligning the drive shaft on the top of the power actuator and the valve shaft.

CAUTION

Undertravel or overtravel of the valve disc, especially at the closed position, may result in poor valve performance and/or damage to the equipment. Make certain that the power actuator travel stops are properly set before installing the valve. Refer to the instruction manuals for the power actuator for information about setting travel stops.

13. Make certain that the power actuator travel stops have been properly set. FieldQ actuator travel stops, the travel stop adjustments are made in the power actuator. The adjusting travel stops procedure is in the FieldQ [Instruction Manual](#).
14. Install the valve in the line using the instructions in the valve instruction manual.

Operation

After the actuator and control valve assembly are installed, the manual actuator is ready for operation.

⚠ WARNING

Applying too much torque to the actuator and valve parts could cause damage to the parts and result in loss of control of key internal valve components (e.g. disc or ball). This loss of control may result in personal injury due to a sudden increase or decrease of pressure within -- or release of pressure from -- the pipeline. To avoid such damage or personal injury, do not exceed the wheel rim force listed in table 2. Also, do not use wrenches or other devices on the handwheel or handwheel shaft to increase operating force.

If the force required to rotate the handwheel exceeds the wheel-rim force listed in table 2, refer to the Maintenance procedures.

Table 2. Actuator Size Selection and Specifications⁽¹⁾

ACTUATOR SIZE	FIELDQ ACTUATOR SIZE	GEAR RATIO	NUMBER OF TURNS TO CLOSE	HANDWHEEL DIAMETER		1080 MAXIMUM TORQUE ⁽²⁾		FIELDQ TORQUE ⁽³⁾		WHEEL RIM FORCE FOR MAXIMUM TORQUE ⁽⁴⁾	
				mm	Inches	N•m	lb•in	N•m	lb•in	N	lbf
AAA/S2	Q40	24:1	6	203	8	271	2,400	58	513	93	21
	Q65							89	788	147	33
AAA/S3	Q100							132	1,168	218	49
AA/S4	Q200	34:1	8.5	305	12	542	4,800	289	2,558	222	50
	Q350							502	4,443	387	87
A/S4	Q600	32:1	8	610	24	926	8,200	866	7,550	276	62
B/S5	Q950	40:1	10					1,356	12,000	1,290	11,300
C/S6	Q1600	54:1	13.5	762	30	2,034	18,000	2,140	18,600	298	67

1. Only the 1080/FieldQ combinations shown are available.
 2. Maximum torque output of the 1080 actuator only.
 3. Torque output of the FieldQ actuator at 100 psig and required 1080 torque output for use with the FieldQ.
 4. Amount of force necessary at rim of the handwheel to match torque output of the FieldQ at 100 psig.

Engaging and Disengaging the Manual Actuator

Engaging the Manual Actuator

1. Engage the manual actuator **before** venting the power actuator loading pressure. Releasing the air pressure prior to engaging could result in undesirable valve rotation.

⚠ WARNING

Undesirable valve rotation or loss of control of key internal valve components (e.g. disc/ball), may result in personal injury due to a sudden increase or decrease of pressure within - or release of pressure from - the pipeline.

2. Pull the ring on the detent mechanism to unlock the lever. At the same time, move the lever into the engaged position until it is against the stop pin and locked in position by the detent mechanism. See figure 3.
3. If the lever sticks midway, turn the handwheel 1/3 turn (2 full turns for units with additional gearbox between the handwheel and lever). Then try the detent lever again. Repeat this step as necessary, turning the handwheel in the same direction, until the lever moves freely (see figure 4). The reason the lever may stick is that the worm is not in proper alignment with the gear (see figure 4). Rotation of the worm will allow for proper alignment. Excessive force should not be required.
4. Shut off supply pressure to the power actuator and bleed off or equalize pressure in the cylinders. If applicable, open the power actuator bypass valve.

Note

If the loading pressure in the power actuator has already been released, you will not need to use the optional bypass relief valve.

Disengaging the Manual Actuator

⚠ WARNING

Disengaging the manual actuator when forces, such as spring compression, cylinder pressure, and dynamic torque, are present may cause sudden, extreme movement of all control valve components. Disengaging the lever with excessive force can result in damage to equipment and violent disturbance of the process.

Damage to equipment resulting in loss of control of internal valve components (e.g. disc/ball) - or violent disturbance of the process may result in personal injury due to a sudden increase or decrease of pressure within - or release of pressure from - the pipeline.

Before disengaging the manual actuator, take appropriate steps to ensure that the return to automatic operation will not result in an extreme repositioning of control valve components. Procedures to determine approximate system balance are given in the following steps.

1. Approximate system balance should be achieved, before disengaging the manual actuator. The system is in balance when the actual valve disc position is approximately the same as the position requested by the automatic control system. Under balanced system conditions, the manual actuator disengaging lever moves freely without use of excessive force.

If after releasing the detent mechanism, the lever does not move freely toward the disengaged position, some system force is causing an imbalance. A forced return to automatic operation under these conditions can cause serious damage to the equipment and violent disturbance of the process.

2. If possible, determine whether the automatic control system is tending to open or close the valve disc, and rotate the handwheel in the appropriate direction until the lever can be easily moved by hand. As an alternate approach, local manipulation of the supply pressure to the power actuator may bring the set point of the automatic system closer to the actual valve disc position.
3. If a smooth transition from manual to automatic operation cannot be ensured, isolate the valve from the process. On Spring Return actuators, position the manual actuator and the disc to the spring fail open or close (whichever is applicable) end of travel so that no position changes will happen when supply pressure is applied to the power actuator. On double-acting actuators, this positioning will not be necessary.
4. Pull the ring on the detent mechanism to unlock the lever. Push the lever into the disengaged position until it is against the stop pin and locked in position by the detent mechanism.
5. Close the bypass valve, if needed, and return supply pressure to the power actuator.

Maintenance

⚠ WARNING

Avoid personal injury from sudden release of process pressure or bursting of parts. Before performing any maintenance operations:

- Do not remove the actuator from the valve while the valve is still pressurized.
- Always wear protective gloves, clothing, and eyewear when performing any maintenance operations to avoid personal injury.
- Disconnect any operating lines providing air pressure, electric power, or a control signal to the power actuator. Be sure the actuator cannot suddenly open or close the valve.
- Use bypass valves or completely shut off the process to isolate the valve from process pressure. Relieve process pressure from both sides of the valve. Drain the process media from both sides of the valve.
- Vent the power actuator loading pressure and relieve any actuator spring precompression. If using a Spring Return actuator, first check to make sure the valve has been moved to the fail safe position to prevent unexpected actuator movement.
- Use lock-out procedures to be sure that the above measures stay in effect while you work on the equipment.
- The valve packing box may contain process fluids that are pressurized, *even when the valve has been removed from the pipeline*. Process fluids may spray out under pressure when removing the packing hardware or packing rings, or when loosening the packing box pipe plug.
- Check with your process or safety engineer for any additional measures that must be taken to protect against process media.

If the force required to rotate the handwheel exceeds the wheel-rim force listed in table 2 check for the following conditions:

- Insufficient lubrication
- Seized actuator parts
- Excessive pressure drop across the valve, or
- Obstruction to the valve disc rotation.

If the manual actuator does not seem to control the process fluid, the worm or drive sleeve gear teeth may be broken, the handwheel pin may be sheared, or the power actuator or internal valve parts may be broken.

Refer to the power actuator and valve instruction manuals if power actuator or valve maintenance is needed.

Lubrication

The interior parts of the 1080 manual actuator should be lubricated on a regular schedule with a quality gear lubricant. The interior parts should also be lubricated whenever difficulty in handwheel rotation indicates a need for lubrication.

⚠ WARNING

Before performing any of these lubrication procedures, observe the steps in the WARNING at the beginning of the Maintenance section.

1. Isolate the control valve from the line pressure, release pressure from both sides of the valve body, and drain the process media from both sides of the valve. If using a power actuator, also shut off all pressure lines to the power actuator, release all pressure from the actuator. Use lock-out procedures to be sure that the above measures stay in effect while you work on the equipment.
2. Remove the bolts that secure the power actuator to the manual actuator adaptor plate and remove the power actuator.
3. Remove the cap screws that secure the gearbox lid and remove the gearbox lid.
4. Coat the worm, the drive sleeve gear teeth, and the bearing surfaces of the gearbox housing and worm with a quality gear lubricant.
5. Replace the cover plate and cap screws using the bolt torques listed in table 5.
6. Replace the power actuator on the manual actuator. Fasten the manual actuator to the adaptor plate using the torque values in table 3.

Table 3. Fisher1080 Adaptor Plate to Gearbox

1080 Actuator	Bolt Size	Bolt Torque N•m	Bolt Torque lb•f
AAA/S2	3/8	39	29
AAA/S3	3/8	39	29
AA/S4	1/2	91	67
A/S4	5/8	163	120
B/S5	5/8	163	120
C/S6	3/4	258	190

Table 4. Fisher 1080 Mounting Bracket to FieldQ Actuator

1080 Actuator	Bolt Size	Bolt Torque N•m	Bolt Torque lb•f
AAA/S2	5/16	22.4	16.5
AAA/S3	5/16	22.4	16.5
AA/S4	3/8	39.3	29
A/S4	1/2	90.8	67
B/S5	5/8	122	90
C/S6	3/4	203	150

Table 5. Fisher 1080 Gearbox Lid

1080 Actuator	Bolt Size	Bolt Torque N•m	Bolt Torque lb•f
AAA/S2	5/16	31.2	23.0
AAA/S3	5/16	31.2	23.0
AA/S4	3/8	56.3	41.5
A/S4	1/2	138	102
B/S5	5/8	277	204
C/S6	3/4	494	364

Figure 3. Typical Fisher 1080 Assembly

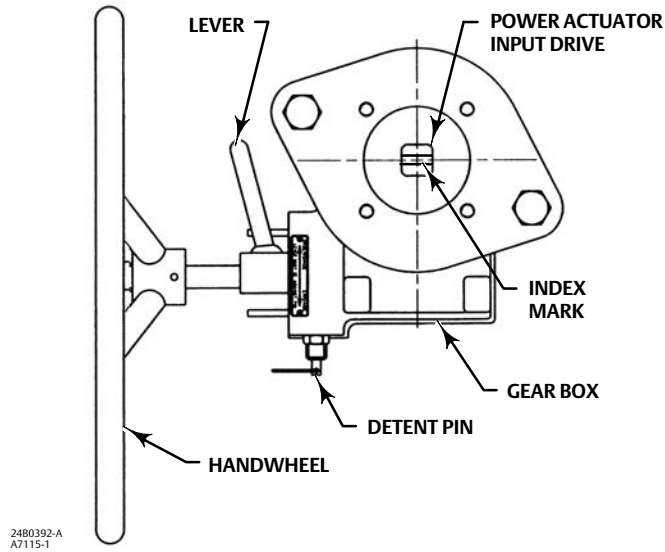
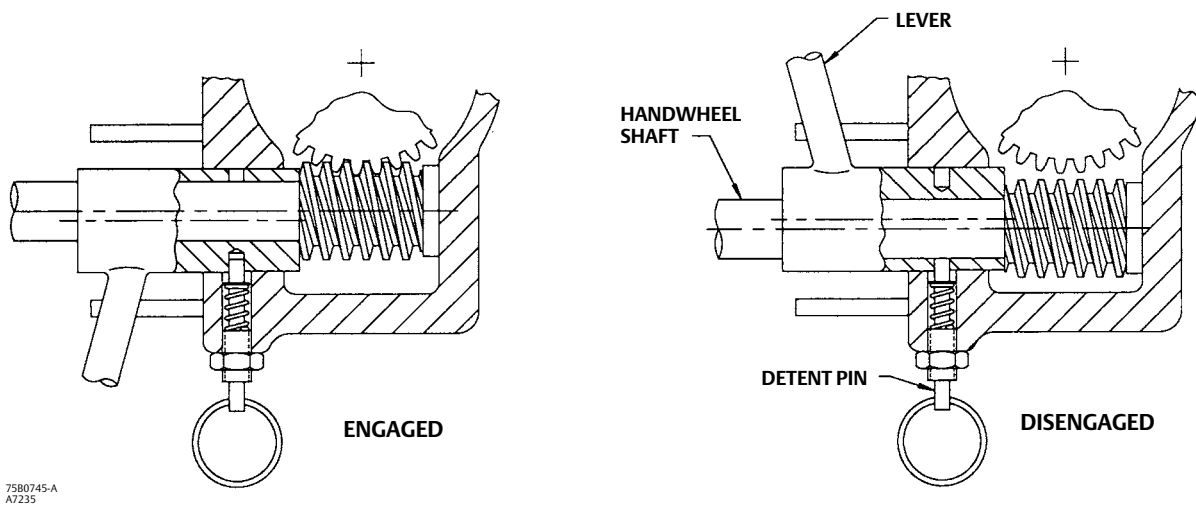

Figure 4. Worm Gear Mechanism



Neither Emerson, Emerson Automation Solutions, nor any of their affiliated entities assumes responsibility for the selection, use or maintenance of any product. Responsibility for proper selection, use, and maintenance of any product remains solely with the purchaser and end user.

Fisher is a mark owned by one of the companies in the Emerson Automation Solutions business unit of Emerson Electric Co. Emerson Automation Solutions, Emerson, and the Emerson logo are trademarks and service marks of Emerson Electric Co. All other marks are the property of their respective owners.

The contents of this publication are presented for informational purposes only, and while every effort has been made to ensure their accuracy, they are not to be construed as warranties or guarantees, express or implied, regarding the products or services described herein or their use or applicability. All sales are governed by our terms and conditions, which are available upon request. We reserve the right to modify or improve the designs or specifications of such products at any time without notice.

Emerson Automation Solutions
Marshalltown, Iowa 50158 USA
Sorocaba, 18087 Brazil
Cernay, 68700 France
Dubai, United Arab Emirates
Singapore 128461 Singapore

www.Fisher.com

